

PLAN (STAGE 1)
(FOR CLARITY, SHEET PILES NOT SHOWN)

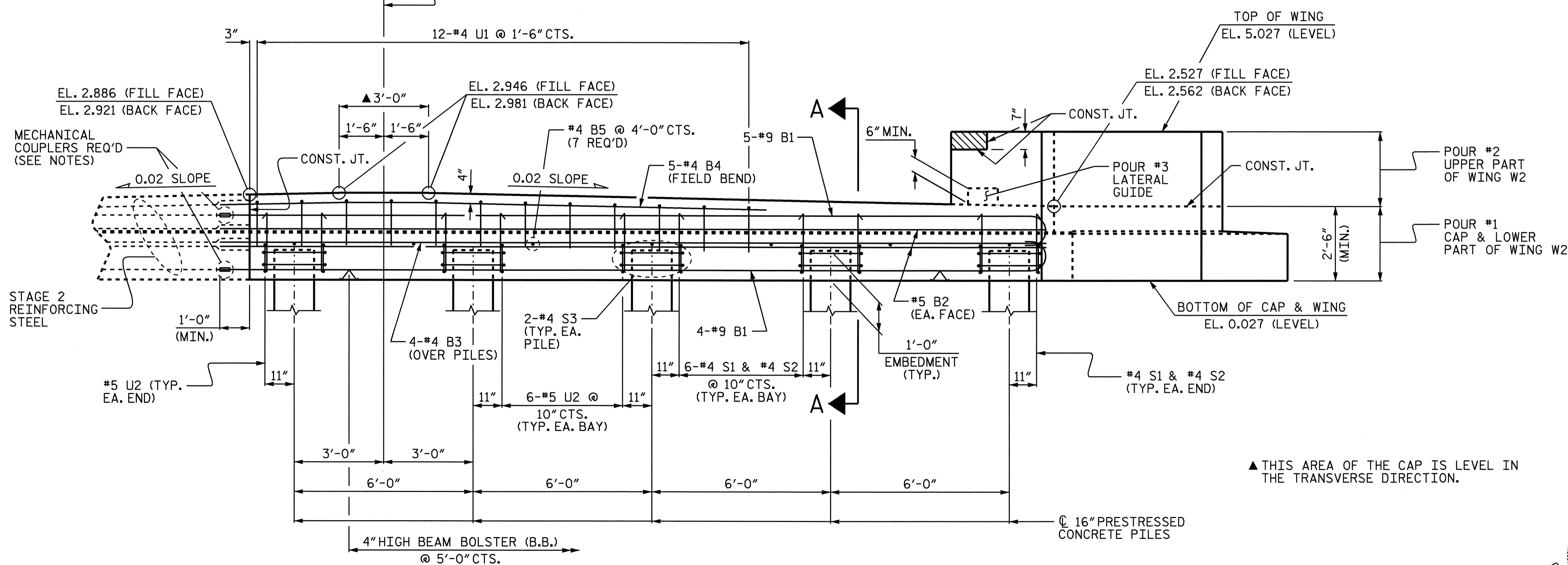

ELEVATION (STAGE 1)
(FOR CLARITY, SHEET PILES NOT SHOWN)

NOTES:

STIRRUPS AND U1 BARS IN CAP MAY BE SHIFTED AS NECESSARY TO CLEAR DOWELS.

ALL REINFORCING STEEL AND BAR SUPPORTS SHALL BE EPOXY COATED ACCORDING TO THE STANDARD SPECIFICATIONS.

CLASS AA CONCRETE SHALL BE USED IN THE END BENT CAP.

THE CONCRETE IN THE SHADED AREA OF THE WINGS SHALL BE POURED AFTER THE PARAPET AND END POST ARE CAST IF SLIP FORMING IS USED.

THE LATERAL GUIDE AT EACH END OF THE CAP IS NOT TO BE POURED UNTIL AFTER THE CORED SLAB UNITS IN THAT STAGE ARE IN PLACE.

THE CONTRACTOR SHALL PROVIDE FOR INSTALLATION OF THE 4\"/>

THE CONTRACTOR'S ATTENTION IS CALLED TO THE FACT THAT THE LENGTHS OF THE #9 \"/>

MECHANICAL COUPLERS SHALL BE USED TO JOIN THE #9 B1 BARS IN STAGE 1 WITH THE #9 B8 BARS IN STAGE 2. THE LOCATION OF THE COUPLERS SHALL BE STAGGERED ON ALTERNATING BARS BY 1 FOOT AND THE #9 B1 AND B8 BARS SHALL BE CUT ACCORDINGLY TO ALLOW A MINIMUM OF 1'-0\"/>

FOR MECHANICAL BUTT SPLICES FOR REINFORCING STEEL, SEE SPECIAL PROVISIONS.

CONCRETE DISPLACED BY THE 16\"/>

ALL STEEL SHEET PILES SHALL BE ASTM A690 MARINE GRADE STEEL AND SHALL BE GALVANIZED IN ACCORDANCE WITH THE STANDARD SPECIFICATIONS.

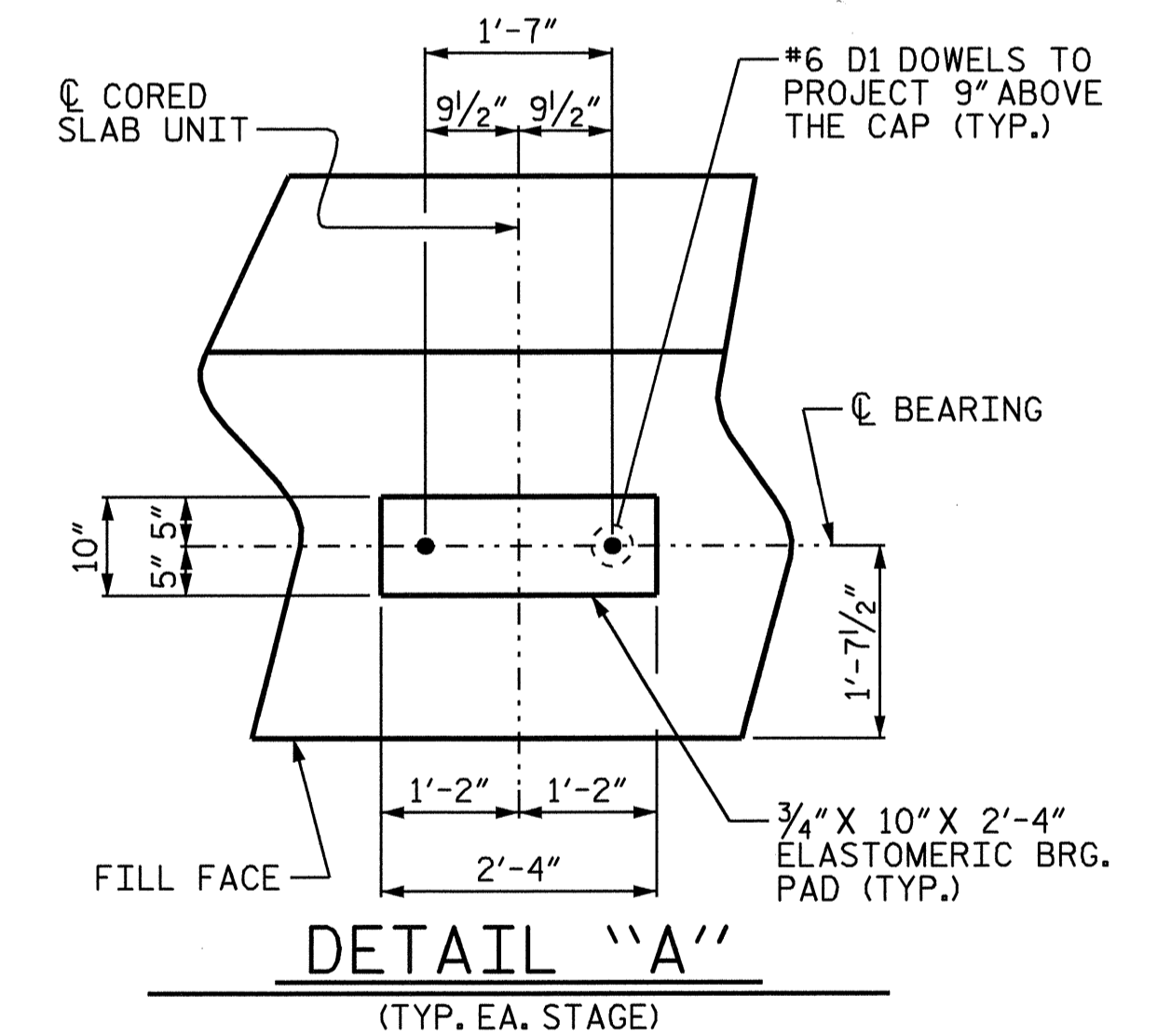

PROJECT NO. B-3348
HYDE COUNTY
STATION: 18+34.00 -L-

SHEET 2 OF 6

STATE OF NORTH CAROLINA
DEPARTMENT OF TRANSPORTATION
RALEIGH

SUBSTRUCTURE
END BENT No. 1
STAGE 1

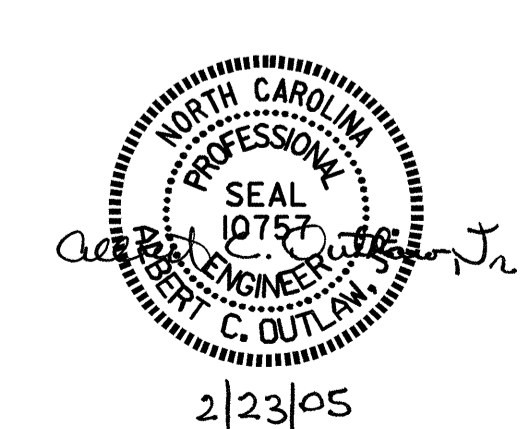

DRAWN BY : P.C. BREWER DATE : 2/25/04
CHECKED BY : C.H. SIMPSON DATE : 3/15/04

22-FEB-2005 09:25
E:\squad\b3348\str1\pbrw\microstation\b3348.sd.EB1.01.dgn
pbrw

| REVISIONS | | | | | | SHEET NO. | |
|-----------|-----|-------|-----|-----|-------|--------------|----|
| NO. | BY: | DATE: | NO. | BY: | DATE: | S-18 | |
| 1 | | | 3 | | | TOTAL SHEETS | 76 |
| 2 | | | 4 | | | | |