

5/14/99

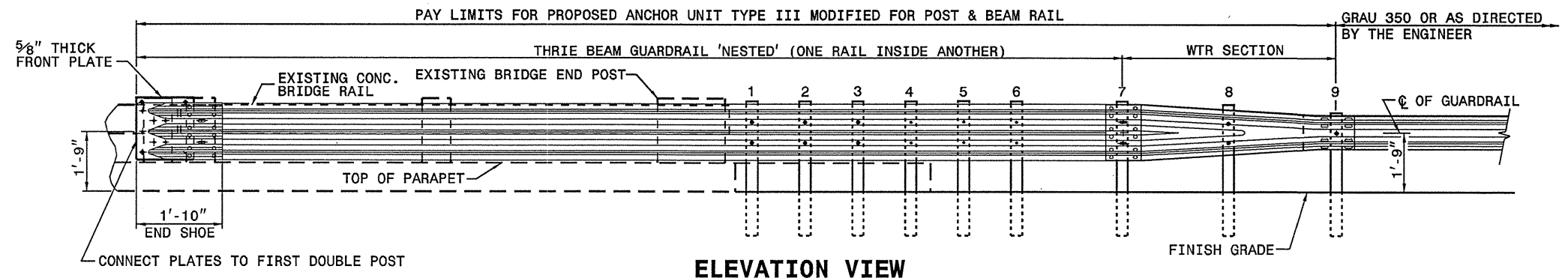

ELEVATION VIEW

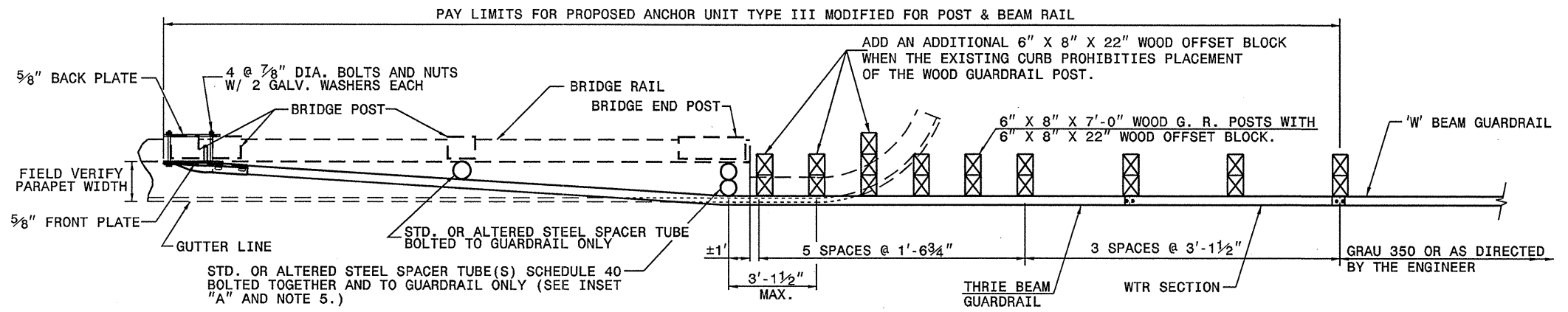

PLAN VIEW

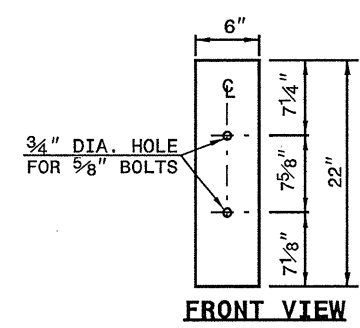

FRONT VIEW

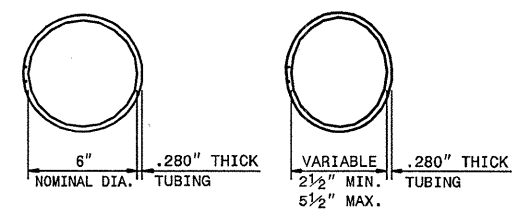

PLAN VIEW

**PLAN VIEW
INSET "A"**

STEEL SPACER TUBE

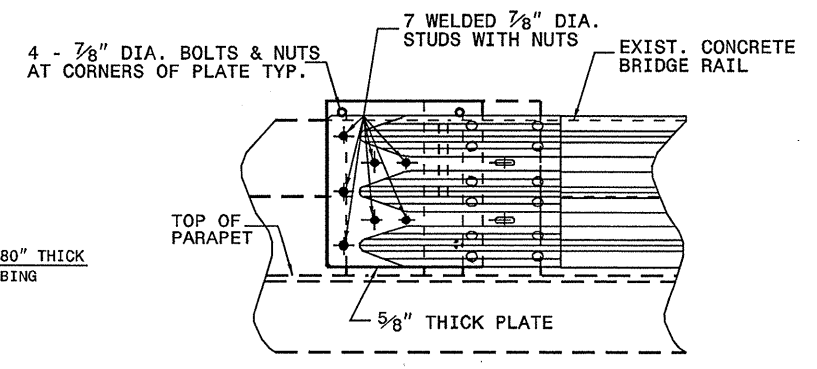

ELEVATION VIEW

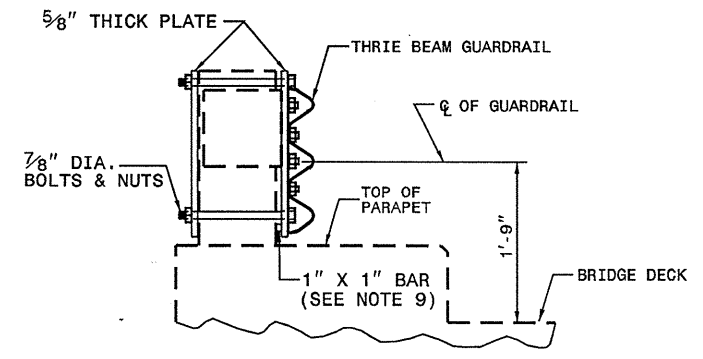

SECTION VIEW

**GUARDRAIL ATTACHMENT
TO BRIDGE POST**

- GENERAL NOTES:**
1. USE NUTS, BOLTS, AND WASHERS CONFORMING TO THE REQUIREMENTS OF A.S.T.M. A-307 AND GALVANIZED IN ACCORDANCE WITH SECTION 1076 OF STAND. SPECS.
 2. TAP NUTS FOR THE 7/8" DIA. STUDS AND BOLTS AFTER GALVANIZING SEE A.S.T.M. A-563.
 3. USE PLATES AND TUBES CONFORMING TO THE REQUIREMENTS OF A.S.T.M. A-36 AND GALVANIZED AFTER FABRICATION IN ACCORDANCE WITH SECTION 1076 OF STAND. SPECS.
 4. ADDITIONAL FIELD HOLES MAY BE DRILLED IN STEEL RAIL AS DIRECTED BY THE ENGINEER.
 5. INSTALL FACE OF GUARDRAIL AS NEAR AS POSSIBLE TO PLUMB WITH THE PARAPET FACE AT BRIDGE END POST SPACER TUBE LOCATION BY USING STANDARD OR ALTERED SPACER TUBES OR A COMBINATION THEREOF OR AS DIRECTED BY THE ENGINEER. FOR VERY SMALL PARAPET WIDTHS, GUARDRAIL MAY BE INSTALLED AGAINST BRIDGE RAIL WITHOUT SPACER TUBES.
 6. DO NOT DRILL BRIDGE RAIL IN ORDER TO INSTALL GUARDRAIL ANCHOR UNIT.
 7. USE THIS DETAIL ONLY FOR BRIGES WITH POST AND BEAM TYPE RAIL.
 8. ATTACH 1" X 1" BAR AND THREADED STUDS TO PLATE WITH 1/4" WELDS ALL AROUND.
 9. 1" X 1" BAR MAY NOT BE NEEDED ON BRIDGE RAILS WHERE FACE OF RAIL DOES NOT PROJECT BEYOND FACE OF POST.
 10. PROVIDE SHOP DRAWINGS OF THE PLATES TO THE ENGINEER FOR APPROVAL BEFORE FABRICATING THE PLATES.
 11. LAP JOINTS IN THE DIRECTION OF TRAFFIC FLOW.
 12. SEE ROADWAY STARDARD DRAWING 862.03 SHEET 4 FOR ADDITIONAL INFORMATION ON THE TYPE III ANCHOR UNIT

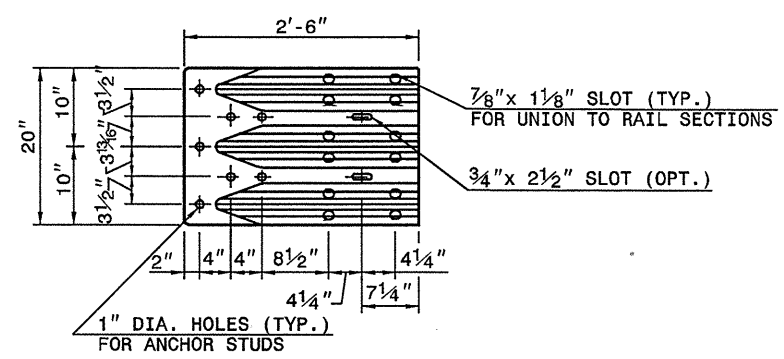

END SHOE

**DESIGN SERVICES UNIT
STANDARDS AND SPECIAL DESIGN**
Office 919-250-4128 FAX 919-250-4119

**GUARDRAIL ANCHOR UNIT
TYPE III MODIFIED
FOR POST & BEAM RAIL**

ORIGINAL BY: E.E. WARD	DATE: 01-03
MODIFIED BY: E.E. WARD	DATE: 02-04
CHECKED BY:	DATE:
FILE SPEC: \\usr\details\stand\bp111	original.dgn