

SPANS A THRU C UNITS

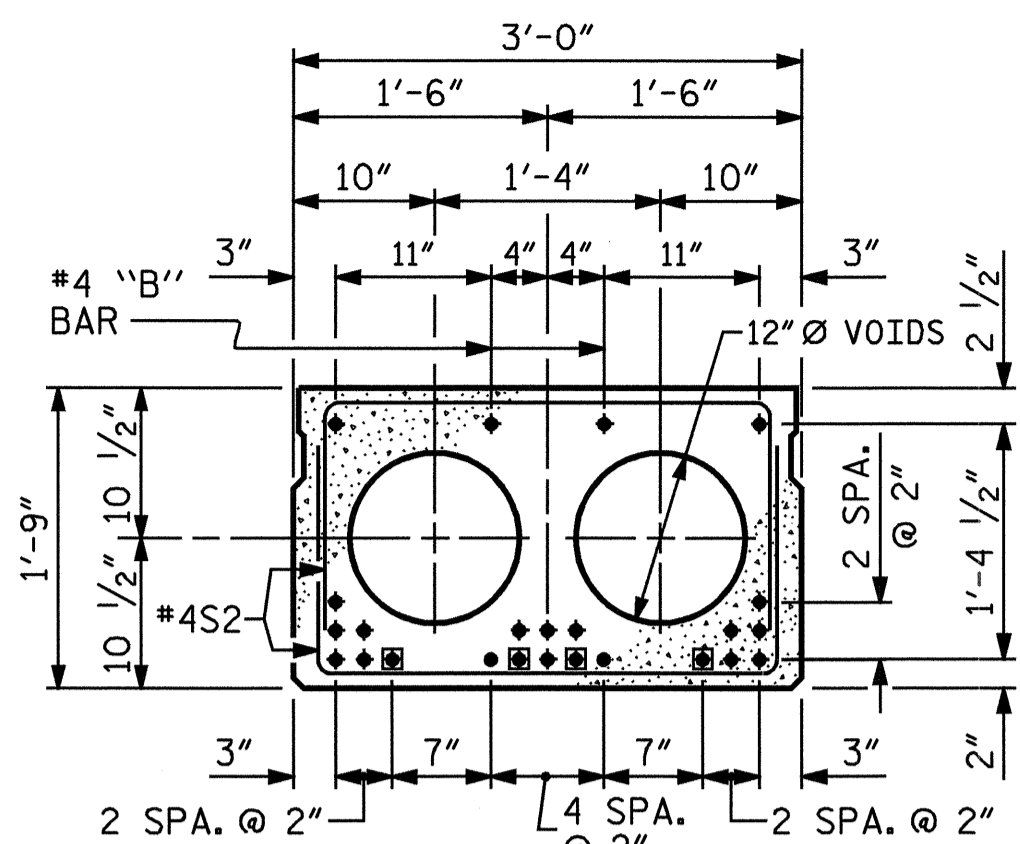

1/2" Ø LOW RELAXATION STRAND LAYOUT FOR INTERIOR SLAB SECTION

TYPE I UNIT & TYPE V UNIT (TYPICAL SPANS A THRU C)

SPAN D UNITS

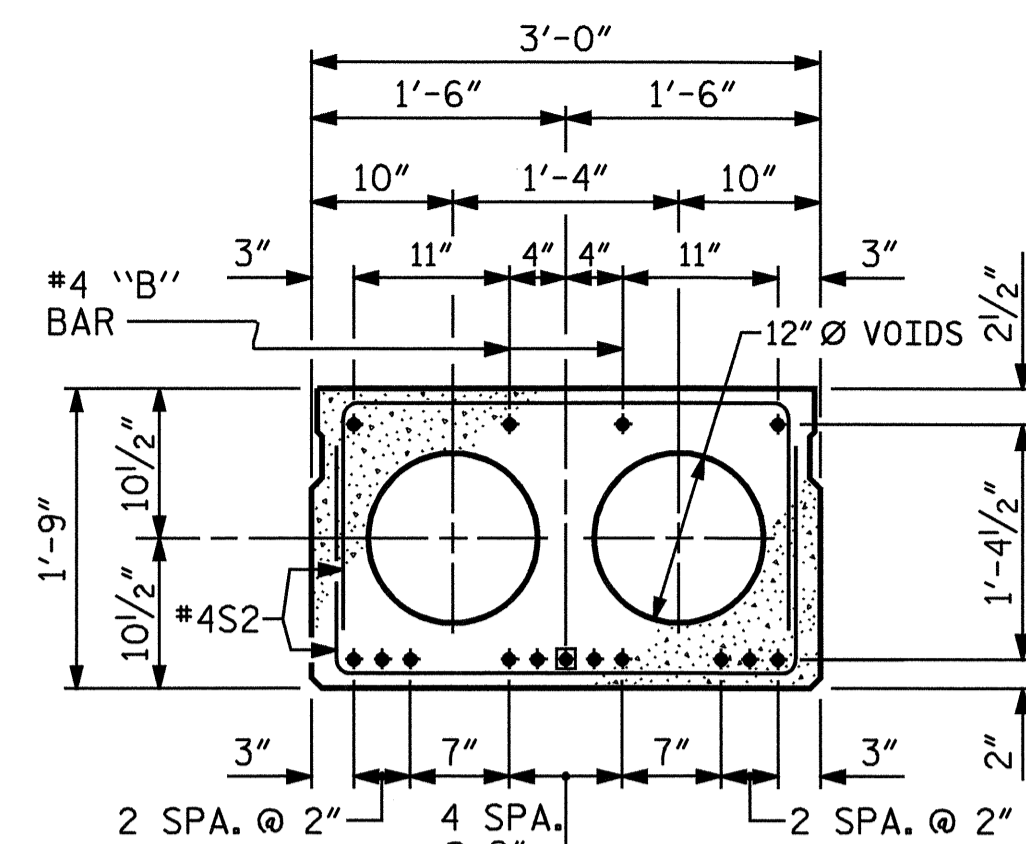

1/2" Ø LOW RELAXATION STRAND LAYOUT FOR INTERIOR SLAB SECTION

TYPE I UNIT & TYPE V UNIT (TYPICAL SPAN D)

SPANS A THRU C UNITS

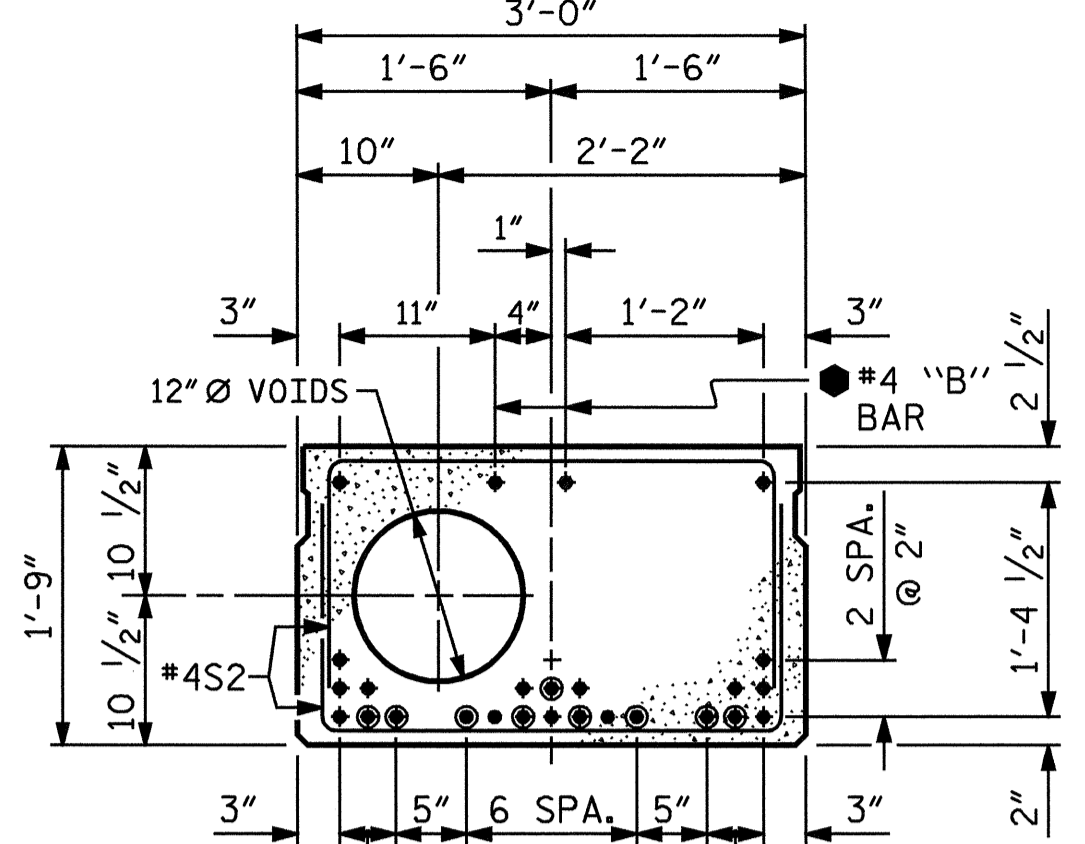

1/2" Ø LOW RELAXATION STRAND LAYOUT FOR INTERIOR SLAB SECTION

TYPE IV (TYPICAL SPANS A THRU C)

SPAN D UNITS

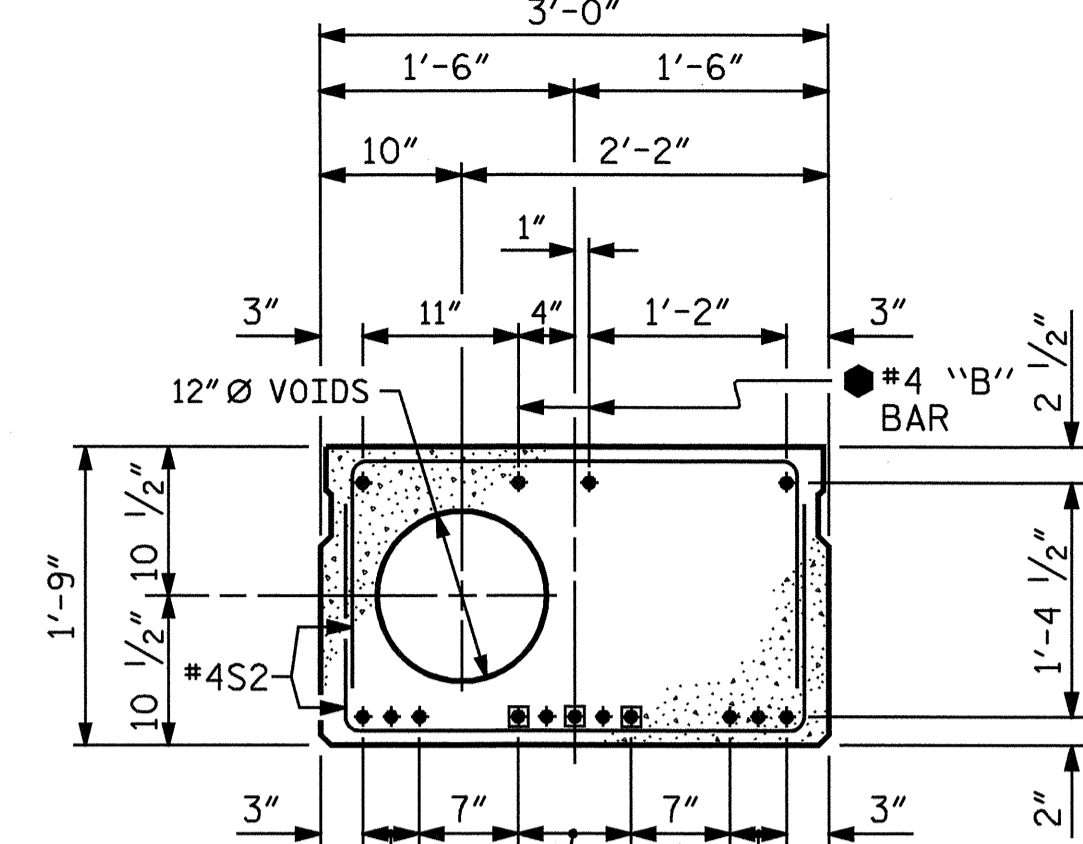

1/2" Ø LOW RELAXATION STRAND LAYOUT FOR INTERIOR SLAB SECTION

TYPE IV (TYPICAL SPAN D)

NOTE TO FABRICATOR: THE #4 "B" BARS IN TYPE II THRU TYPE IV CORED SLAB UNITS ARE SPACED DIFFERENTLY THAN IN THE TYPE I AND V CORED SLAB UNITS.

BOND SHALL BE BROKEN ON THESE STRANDS FOR A DISTANCE OF 4'-0" FROM END OF CORED SLAB UNIT, SEE STANDARD SPECIFICATIONS ARTICLE 1078-7.

BOND SHALL BE BROKEN ON THESE STRANDS FOR A DISTANCE OF 7'-6" FROM END OF CORED SLAB UNIT, SEE STANDARD SPECIFICATIONS ARTICLE 1078-7.

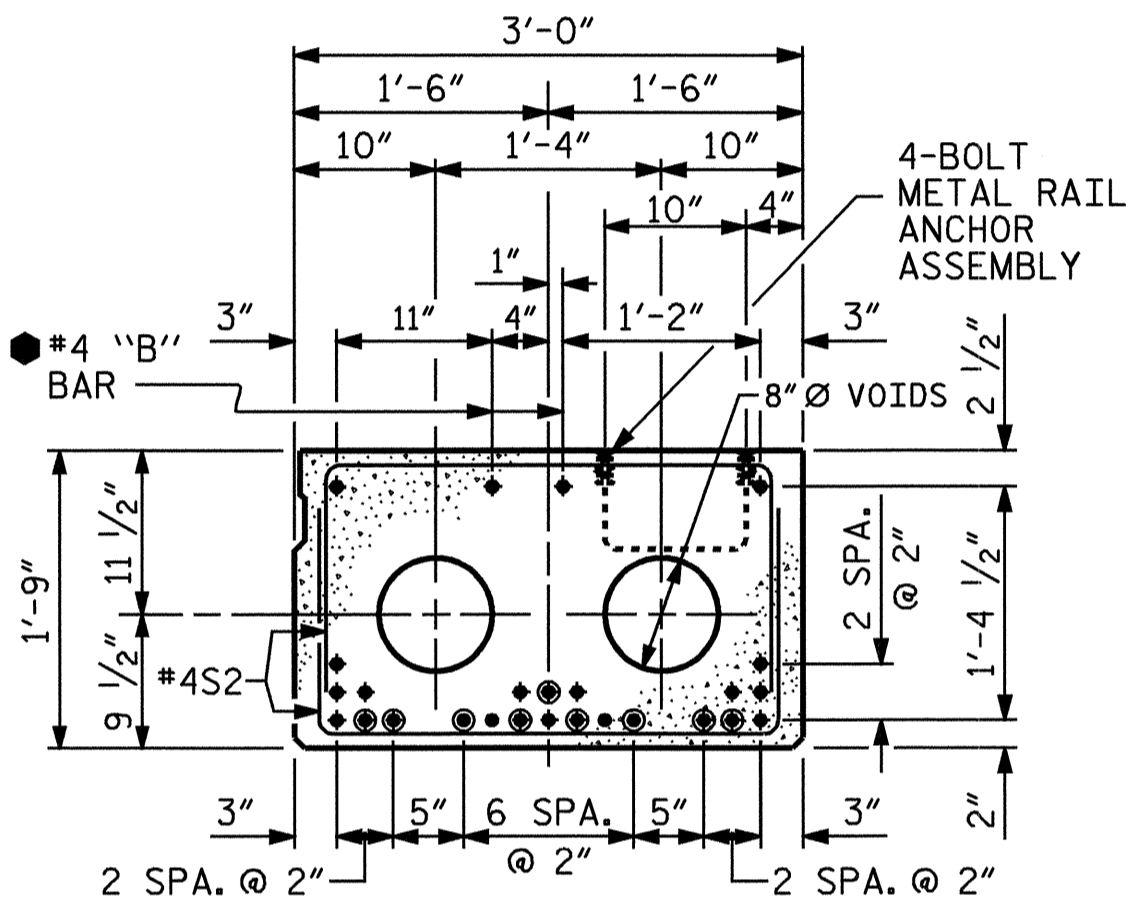

1/2" Ø LOW RELAXATION STRAND LAYOUT FOR EXTERIOR SLAB SECTION

INTERIOR TYPE II UNIT SHOWN, EXTERIOR TYPE II UNIT SIMILAR (TYPICAL SPANS A THRU C) (FOR LOCATION OF ANCHORAGE ASSEMBLY, SEE "WOODEN RAIL" SHEETS.)

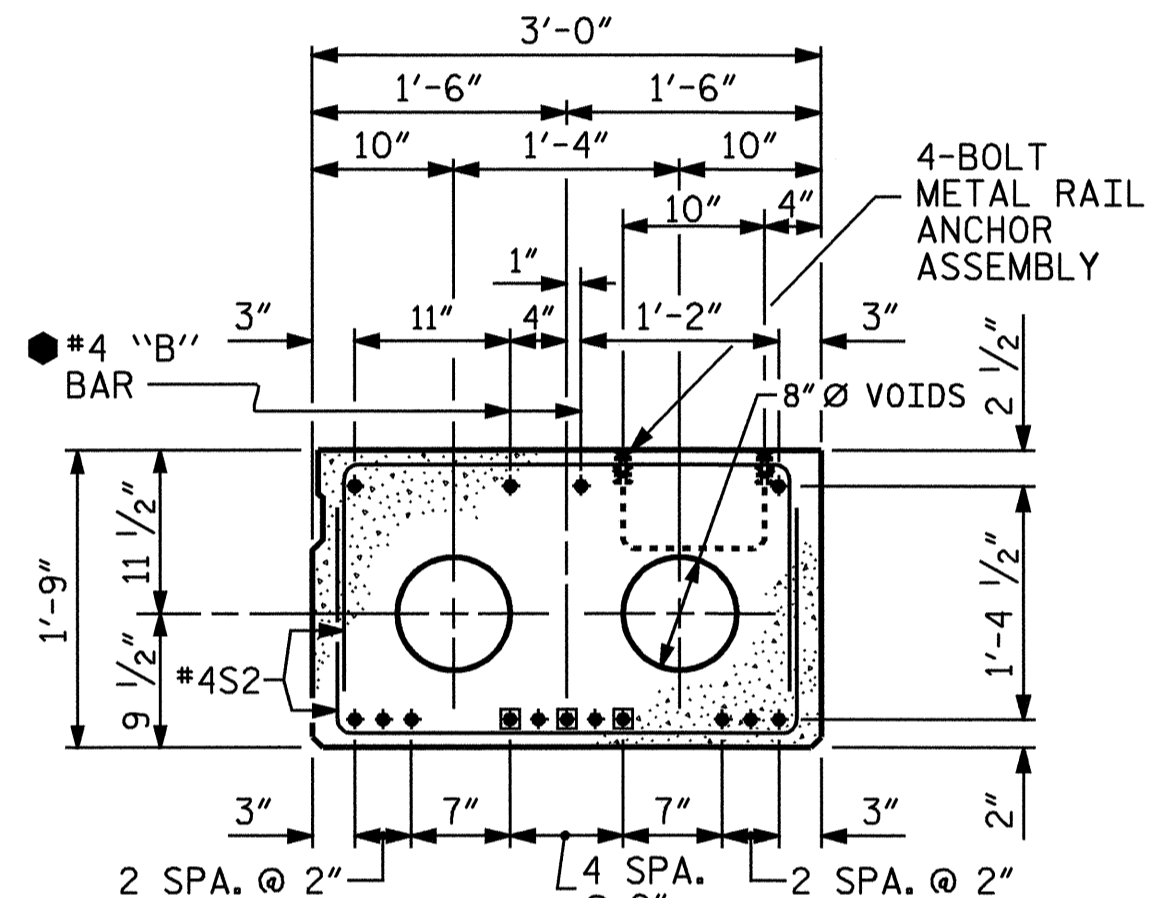

1/2" Ø LOW RELAXATION STRAND LAYOUT FOR EXTERIOR SLAB SECTION

INTERIOR TYPE II UNIT SHOWN, EXTERIOR TYPE II UNIT SIMILAR (TYPICAL SPAN D) (FOR LOCATION OF ANCHORAGE ASSEMBLY, SEE "WOODEN RAIL" SHEETS.)

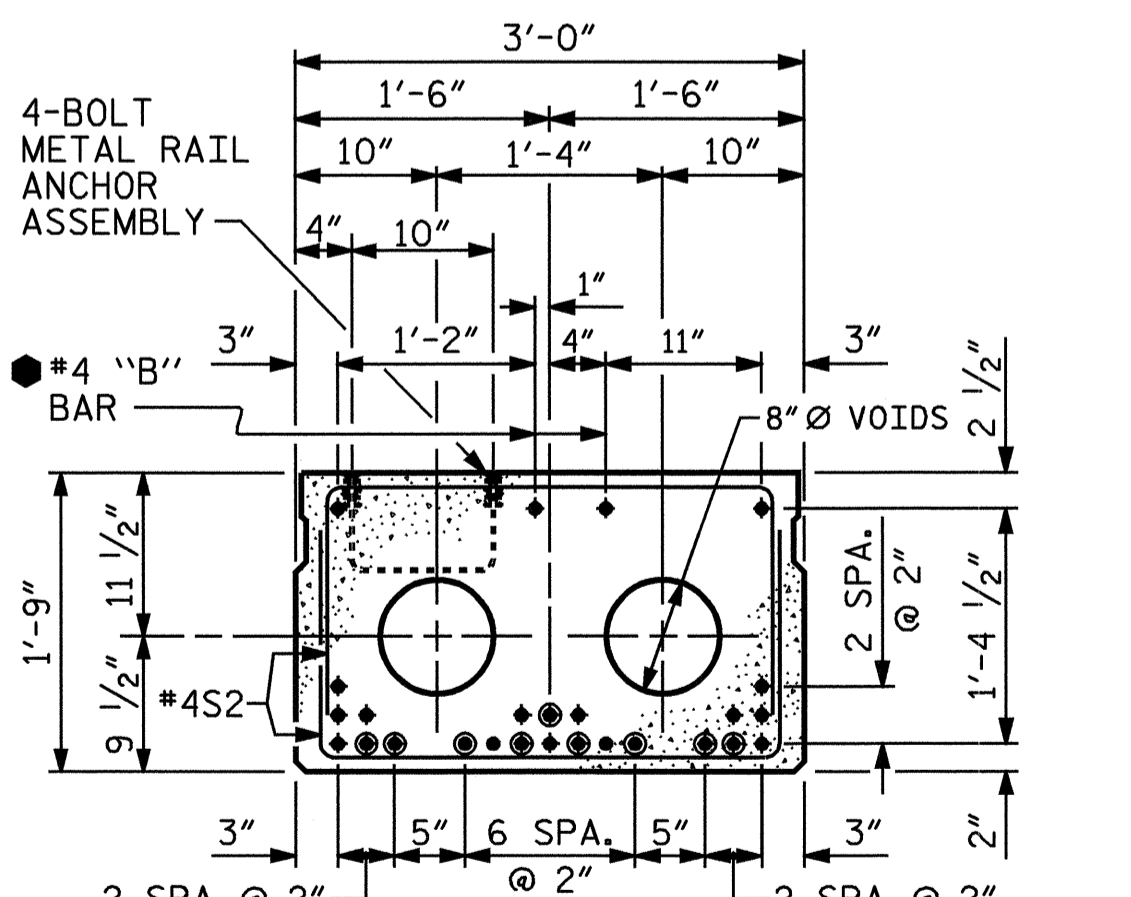

1/2" Ø LOW RELAXATION STRAND LAYOUT FOR INTERIOR SLAB SECTION

INTERIOR TYPE III UNIT SHOWN, EXTERIOR TYPE III UNIT SIMILAR (TYPICAL SPANS A THRU C) (FOR LOCATION OF ANCHORAGE ASSEMBLY, SEE "WOODEN RAIL" SHEETS.)

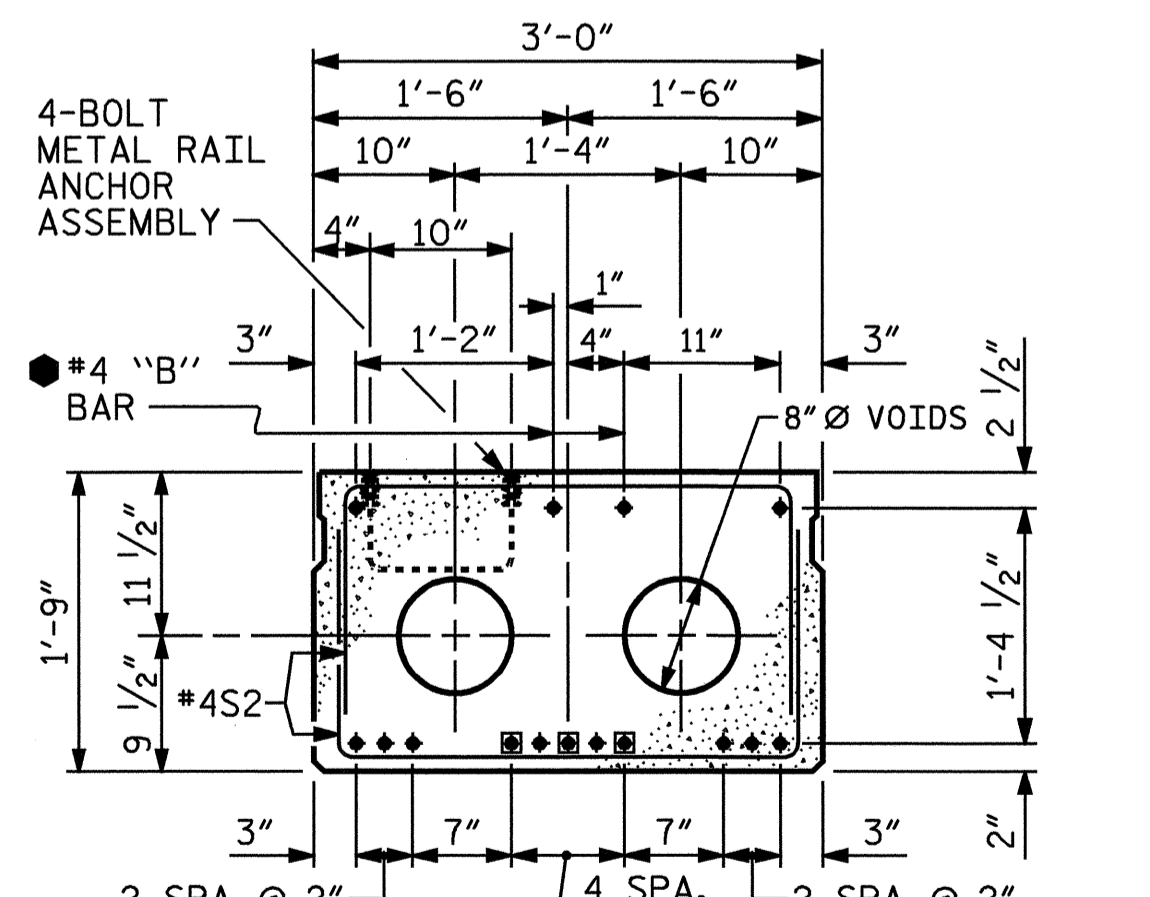

1/2" Ø LOW RELAXATION STRAND LAYOUT FOR INTERIOR SLAB SECTION

INTERIOR TYPE III UNIT SHOWN, EXTERIOR TYPE III UNIT SIMILAR (TYPICAL SPAN D) (FOR LOCATION OF ANCHORAGE ASSEMBLY, SEE "WOODEN RAIL" SHEETS.)

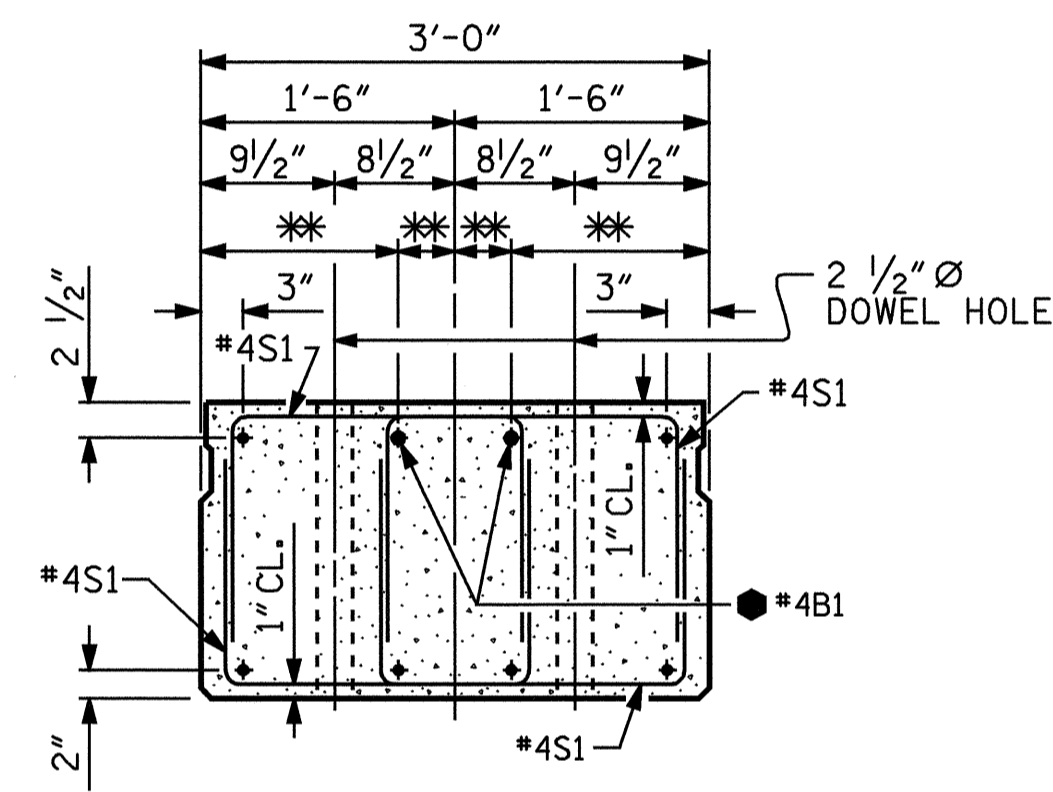

END ELEVATION SHOWING PLACEMENT OF DOUBLE STIRRUPS AND LOCATION OF DOWEL HOLES. STRAND LAYOUT NOT SHOWN. INTERIOR SLAB SECTION SHOWN-EXTERIOR SLAB SECTION SIMILAR EXCEPT FOR SHEAR KEY LOCATION. (** = VARIES)

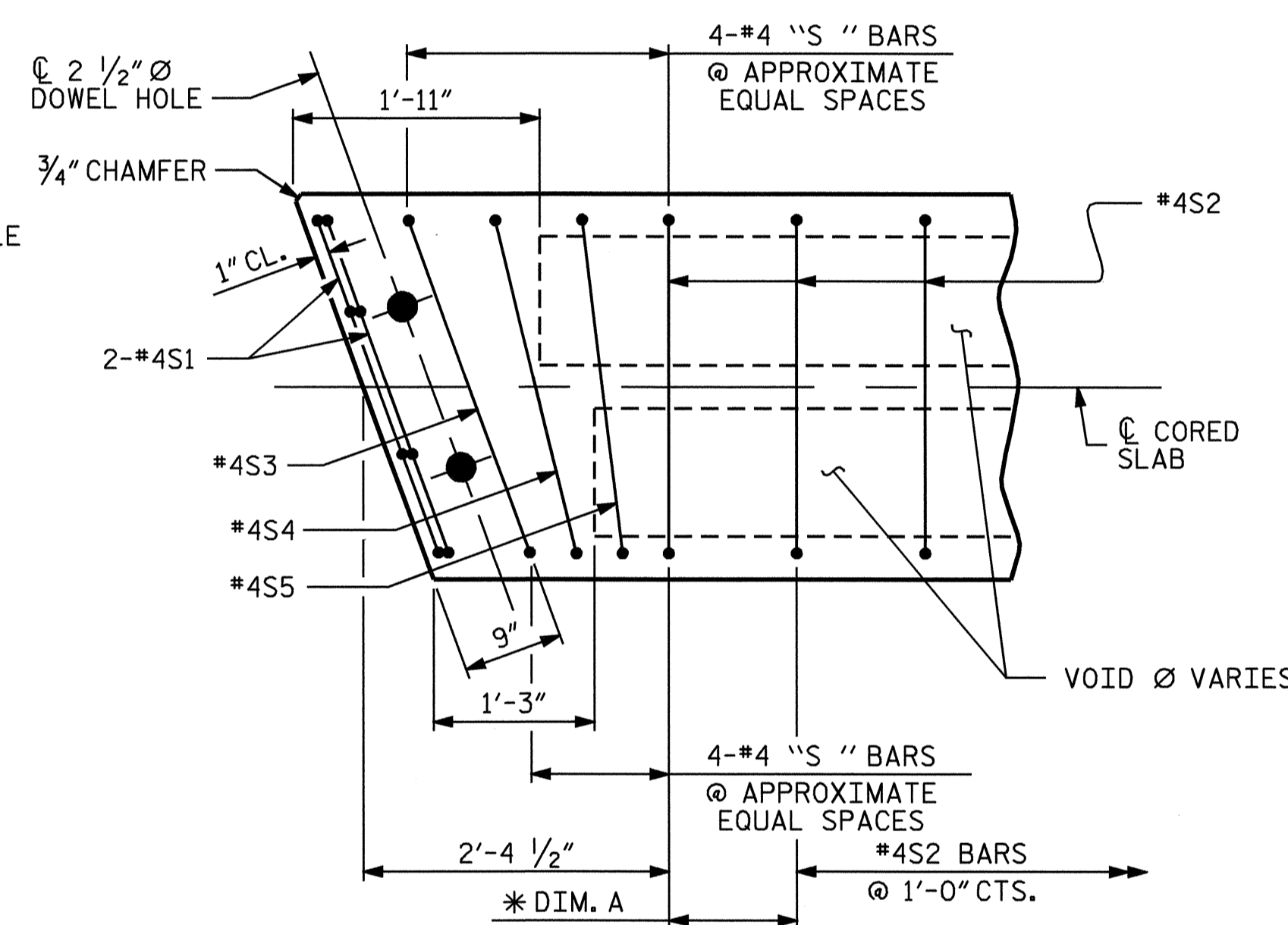

PART PLAN END OF CORED SLAB UNIT

NOTE: EXTERIOR SECTION SHOWN-INTERIOR SECTION SIMILAR. * SEE "PLAN OF 3'-0" X 1'-9" CORED SLAB UNIT" SHEETS 1-3 FOR DIM. A.

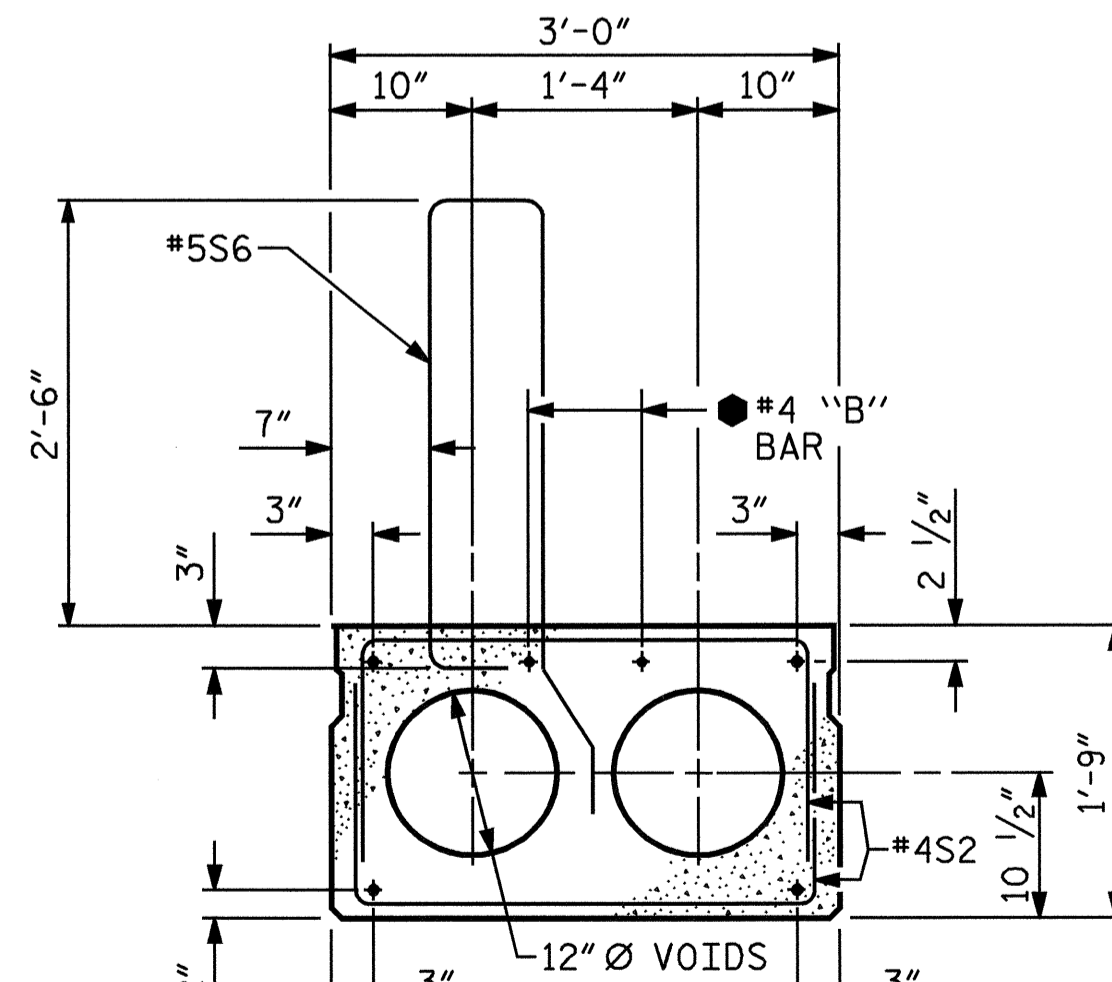

INTERIOR SLAB SECTION

FOR PRESTRESSED STRAND LAYOUT, SEE INTERIOR SLAB SECTION, TYPE V FOR SPANS A,B,C,& D.



PROJECT NO. B-3445
CURRITUCK COUNTY
STATION: 24+18.00 -L-

SHEET 2 OF 3

STATE OF NORTH CAROLINA
DEPARTMENT OF TRANSPORTATION
RALEIGH
SUPERSTRUCTURE
TYPICAL SECTIONS

REVISIONS						SHEET NO.
NO.	BY:	DATE:	NO.	BY:	DATE:	S-6
1			3			TOTAL SHEETS
2			4			44

DRAWN BY: M. J. OSTRISHKO DATE: 11-20-01
CHECKED BY: K. D. LAYNE DATE: 1-18-02