

PLAN

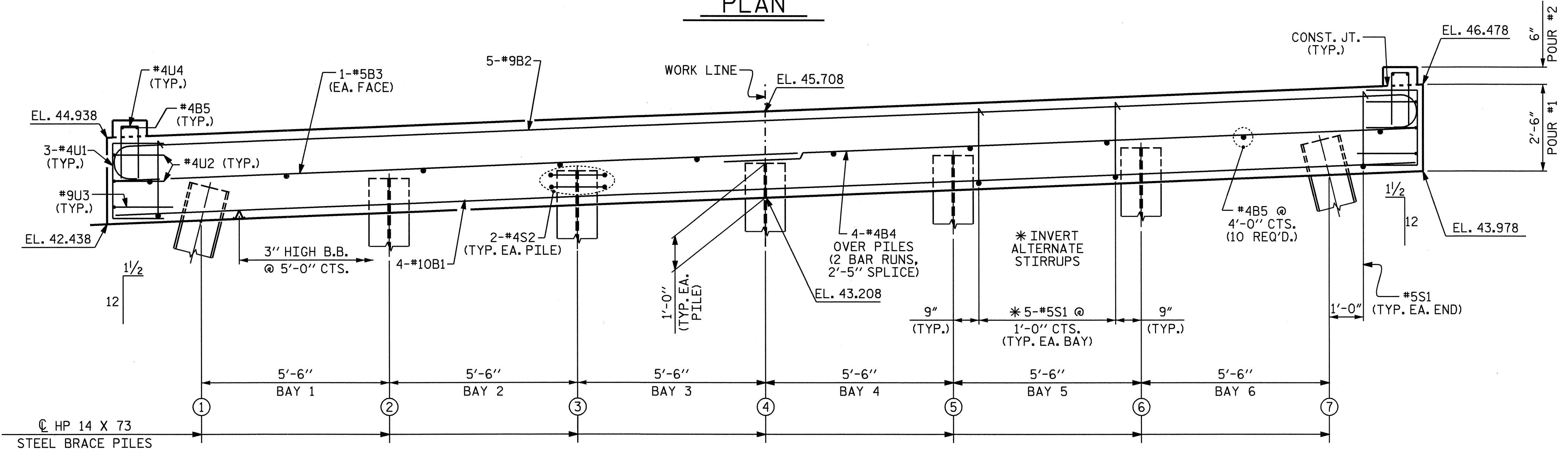

ELEVATION

NOTES

STIRRUPS IN CAP MAY BE SHIFTED AS NECESSARY TO CLEAR DOWELS.
 FOR PILE SPLICE DETAILS, SEE END BENT #1, SHEET 3 OF 3.
 THE LATERAL GUIDE AT EACH END OF CAP IS NOT TO BE POURED UNTIL AFTER THE CORED SLAB UNITS ARE IN PLACE.
 FOR CONSTRUCTION OF SUBSTRUCTURE, SEE SPECIAL PROVISIONS.

TOP OF PILE ELEVATIONS	
1	43.548
2	43.768
3	43.988
4	44.208
5	44.428
6	44.648
7	44.868

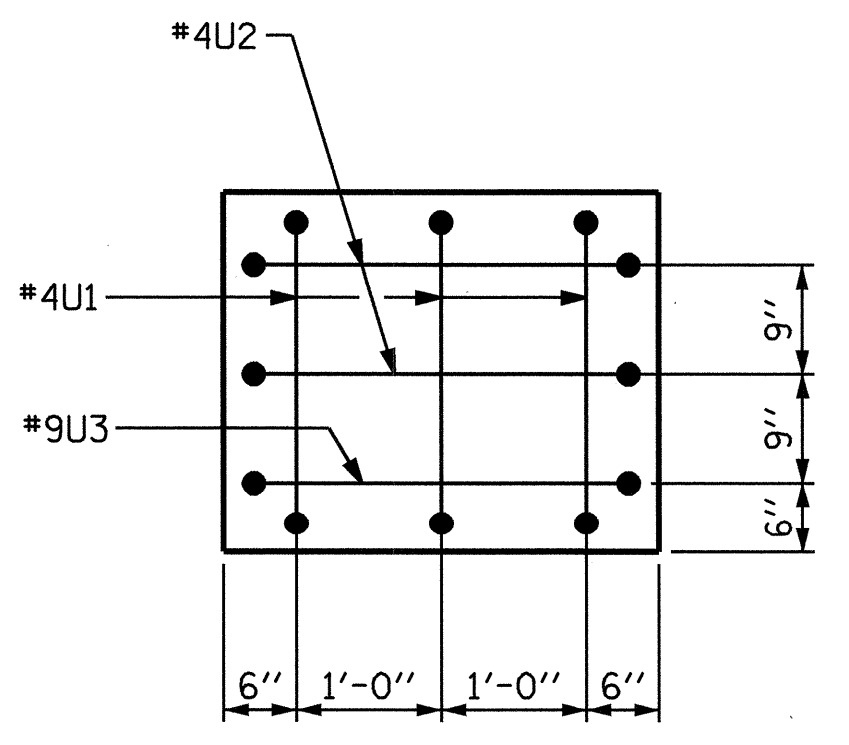

END VIEW

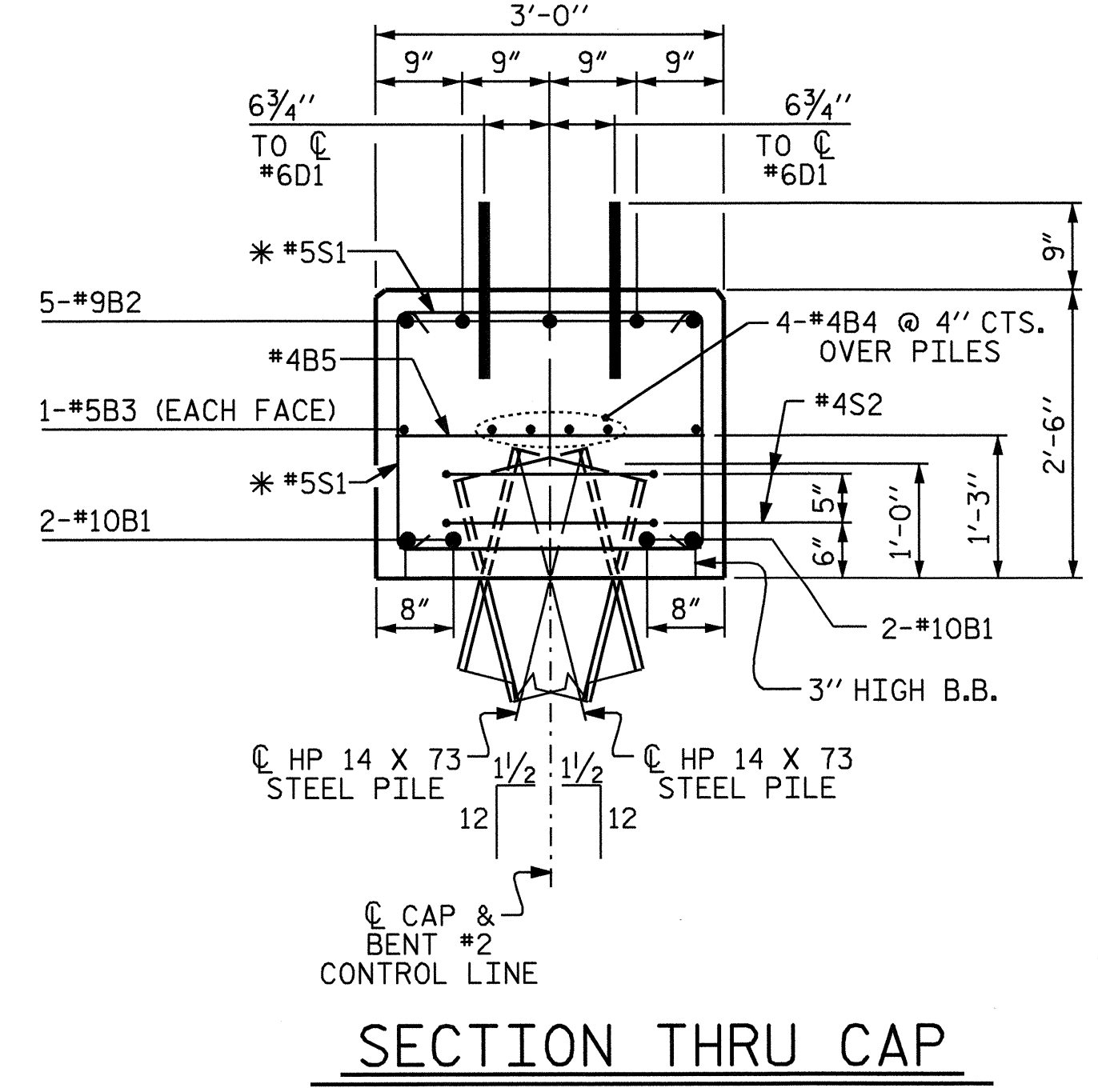

SECTION THRU CAP

BILL OF MATERIAL					
BENT #2					
BAR	NO.	SIZE	TYPE	LENGTH	WEIGHT
B1	4	10	STR	38'-2"	657
B2	5	9	1	40'-7"	690
B3	2	5	STR	38'-2"	80
B4	8	4	STR	20'-5"	109
B5	14	4	STR	2'-8"	25
D1	48	6	STR	1'-6"	108
S1	32	5	2	7'-10"	261
S2	14	4	3	7'-7"	71
U1	6	4	4	5'-0"	20
U2	4	4	4	5'-6"	15
U3	2	9	4	9'-10"	67
U4	8	4	4	3'-6"	19
TOTAL REINFORCING STEEL = 2122 LBS.					
CLASS A CONCRETE BREAKDOWN					
POUR #1 (CAP)				10.7	C.Y.
POUR #2 (LATERAL GUIDE)				0.1	C.Y.
TOTAL CLASS A CONCRETE				10.8	C.Y.

HP 14 X 73 STEEL PILES
NO. 7 525 LIN. FT.

GALVANIZING STEEL PILES LUMP SUM

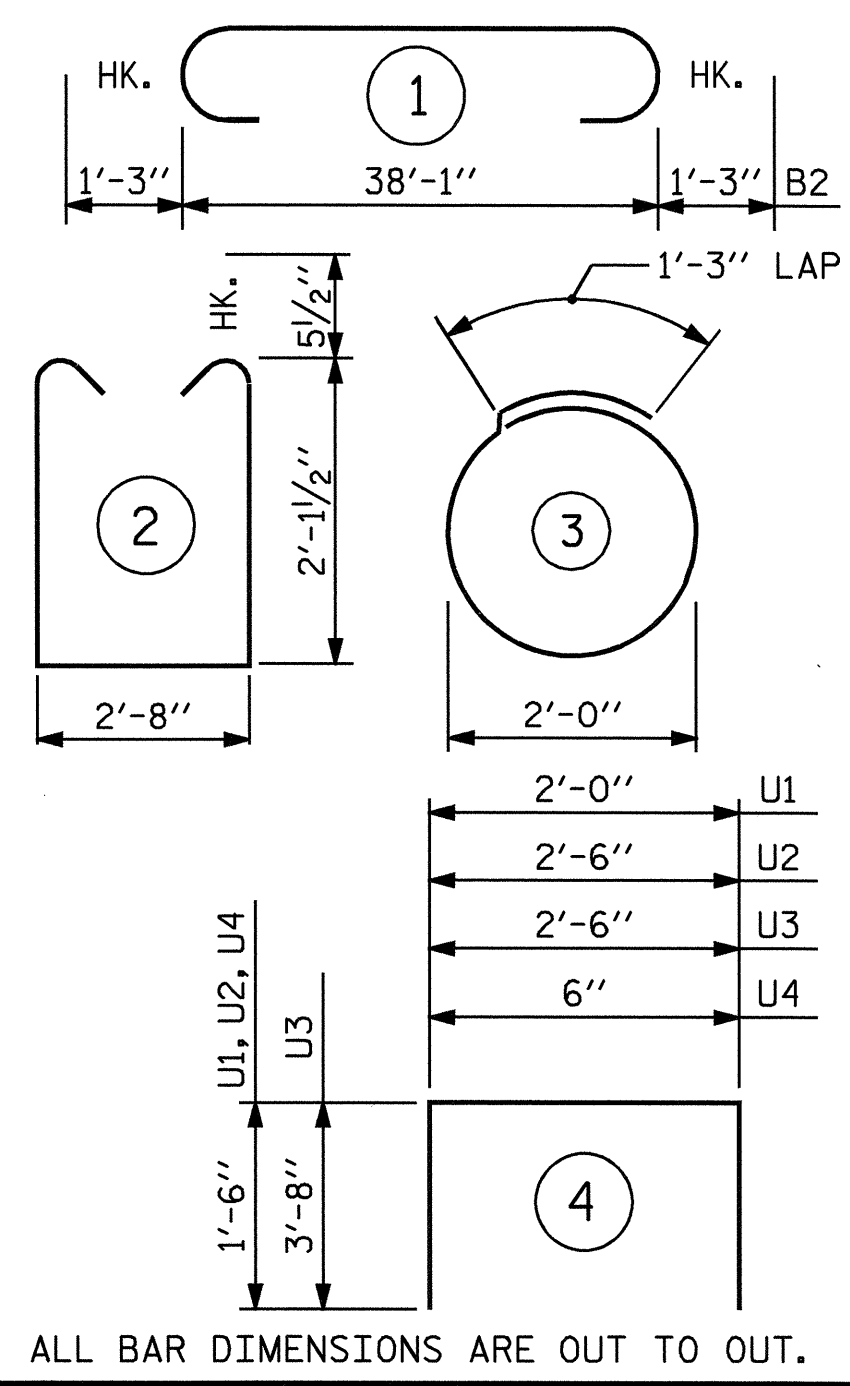

PROJECT NO. B-4027
 BERTIE COUNTY
 STATION: 18+50.00 -L-

STATE OF NORTH CAROLINA DEPARTMENT OF TRANSPORTATION RALEIGH					
SUBSTRUCTURE BENT #2					
REVISIONS					
NO.	BY:	DATE:	NO.	BY:	DATE:
1			3		
2			4		



DRAWN BY: J.P. ADAMS DATE: 7/12/05
 CHECKED BY: S.H. SOCKWELL DATE: 7/21/05

SHEET NO. S-14
 TOTAL SHEETS 23