

**Project Special Provisions
Structure**

Table of Contents

	Page #
Construction, Maintenance, and Removal of Temporary Structure at Station 17+03.50 -L- (10-12-01)	1
Sand Seal (10-12-01)	2
Drilled Piers (6-7-05)	3
Crosshole Sonic Logging (6-7-05)	23
Epoxy Protective Coating (10-12-01)	29
Falsework and Formwork (10-12-01)	31
Submittal of Working Drawings (6-7-05)	36
Construction, Maintenance & Removal of Temporary Access at Sta. 17+03.50 -L- (2-14-04)	42
Elastomeric Bearings (10-03-02)	43
Unclassified Structure Excavation at Station 17+03.50 -L- (12-12-02)	43
Prestressed Concrete Members (3-04-05)	43
Crane Safety (08-15-05)	44
Prestressed Concrete Box Beam (3-04-05)	45



PROJECT SPECIAL PROVISIONS
STRUCTURE

PROJECT B-4007

ALLEGHANY COUNTY

CONSTRUCTION, MAINTENANCE AND REMOVAL
OF TEMPORARY STRUCTURE AT STATION 17+03.50 -L-

(10-12-01)

Construct, maintain and afterwards remove a temporary structure in accordance with the applicable parts of the Standard Specifications and this Special Provision, (structure only; the approaches are not a part of this pay item). Provide a temporary structure with a minimum overall length of 123 feet (meters). Center the length of the structure about Station 13+49.50-Detour with the alignment, grade, and skew as indicated on the Roadway plans. If the skew is not 90°, lengthening the structure to accommodate a 90° skew is permitted. Provide a temporary structure with a minimum clear roadway width of 28 feet (meters) and an underclearance elevation no less than elevation 2418.2.

Design the temporary structure for HS20 (MS18) live load in accordance with the current edition of the AASHTO Standard Specifications for Highway Bridges. The design of temporary structures need not satisfy the seismic design criteria of AASHTO Division I-A "Seismic Design", Section 3. Design and construct the bridge rails on the temporary structure in accordance with the current edition of the AASHTO Standard Specifications for Highway Bridges and such that guardrail can be bolted to the ends of the bridge rails.

Provide a timber floor of laminated construction on the temporary structure. Place a sufficiently thick bottom layer of lumber normal to the centerline of roadway and a top layer of 2" x 8" (50 mm x 200mm) lumber on a 45° skew with the centerline of roadway. Lumber wider than 8" (200mm) is permitted if approved. For the bottom layer, use lumber that is dressed on all four sides to ensure a uniform width and thickness. For the top layer, use lumber dressed only on one side to ensure a uniform thickness. Place the lumber so that the crown of the lumber is the rough side and is "facing up" in order to receive a tack coat. Apply sand seal to the timber floor after the top layer of lumber is completed. When preservative treatment is specified, follow AWWA Standards for the applicable use.

If the timbers in the bottom layer of lumber are at least 8 inches (200mm) thick, an asphalt wearing surface of at least 3 inches (75 mm) in thickness is permitted in lieu of the sand seal and top layer of lumber. Bolt the timbers together horizontally in minimum 4 foot (1.2m) mats. Prior to the assembly of the mats, have the Materials and Tests Unit, or their authorized representative, inspect the timber on all four sides. Place the face of timbers in contact with girder flanges so that they are even and positively bear on all girder flanges. If necessary, provide shimming to ensure positive bearing. Minor variations are permissible in the evenness of the top surface of timbers that is in contact with the asphalt. Secure the timber floor to the girder flanges at regular intervals.

Other floor systems are permitted if approved.

If timber piles are used, use piles that are new and conform to ASTM D25. Rough-peeled or clean-peeled untreated timber piles are permitted.

Submit design calculations to the Engineer that, as a minimum, include stress calculations for the following structural components: railings, rail post, rail post connections, timber floor, main girders or floor beam system, bent cap, pile bearing, pile as a structural member and longitudinal and lateral stability of pile bents if necessary. For stream crossings, determine the pile stability assuming a scour depth equal to 250% of the pile diameter or width below the existing bed elevation. The Engineer may require a more detailed analysis of scour depth for pile bents containing more than a single row of piles.

Include material specifications for all new and used materials, including commercial grades and species of timber and lumber, in the detail drawings of the structure. In addition, show the location and a detailed sketch of the used materials indicating condition of the material, the location and geometry of existing but unused holes, attachments left over from previous use and any other irregularities in the material.

Indicate the condition of the used materials in the design calculations. Provide access to any used materials for inspection prior to assembly.

Used high strength bolts, nuts and washers are permitted only in already bolted-up connections of used diaphragm and girder systems that are proposed for reuse. The use of used bolts is limited to secondary member connections such as diaphragms and is subject to approval.

Have all timber and lumber inspected by the Materials and Tests Unit or their authorized representative before shipping it to the project. The use of ungraded timber and lumber is not permitted. Use material conforming to grading rules of SPIB, NELMA or other nationally recognized specification.

The lump sum price bid for "Construction, Maintenance and Removal of Temporary Structure at Station _____" will be full compensation for the above work including all materials, equipment, tools, labor and incidentals necessary to complete the work.

SAND SEAL

(10-12-01)

This Special Provision covers the application of a liquid asphalt material and one or more applications of fine aggregate on the surface of wooden deck detour bridges.

Use materials meeting the requirements of Division 10 of the Standard Specifications shown below:

- Asphalt, Grade CRS-2 or CRS-1..... Articles 1020-6, 1020-7
- Aggregate, #1S Article 1005-3

Clean and dry the surface of the bridge before applying treatment.

Apply asphalt emulsion at a rate of 0.15 - 0.20 gal/yd² (0.7 - 0.9 liters/m²) followed by a uniform coverage of sand at a rate of 10 – 15 lbs/yd² (5.4 - 8.1 kg/m²).

Roll the seal with a pneumatic-tired roller. Allow the seal to cure for a minimum of 24 hours before opening to traffic.

Maintain the sand seal in an acceptable condition during the life of the detour, making additional applications as necessary.

The lump sum price bid for “Construction, Maintenance, and Removal of the Temporary Structure at Station _____” will be full compensation for the construction and maintenance of the sand seal.

DRILLED PIERS

(6-7-05)

1.0 GENERAL

A. Description

The work in this special provision governs the construction of Drilled Piers, also known as "Drilled Shafts" and "Caissons". Drilled piers are a reinforced concrete section, cast-in-place against in situ material or permanent steel casing. Drilled piers are a straight shaft type and vertical. Construct drilled piers in accordance with the details and dimensions shown on the plans and this special provision.

B. Work Experience

The Contractor/Subcontractor and the Contractor's/Subcontractor's superintendent performing the work described in this special provision must have installed drilled piers of both diameter and length similar to those shown on the plans and have a minimum of five years experience with drilled pier excavation and both dry and wet concrete placement. This work should be performed under the supervision of the Contractor's/Subcontractor's superintendent, who is knowledgeable and experienced in the construction of drilled piers using casing and/or slurry. The Contractor/Subcontractor should use equipment that is sufficient to complete the work in accordance with this special provision.

To verify the Contractor's/Subcontractor's ability to meet these requirements, submit a list containing a description of at least two projects completed in the last five years on which those responsible for the drilled pier construction have installed drilled piers of similar size shown on the plans and with similar construction methods anticipated for this project. Include the names and phone numbers of the project owner's representatives who can verify the Contractor/Subcontractor's participation and performance on the listed projects.

C. Construction Sequence Plan

Submit two copies of a drilled pier construction sequence plan for all the drilled piers for review and acceptance 30 days prior to beginning construction of the drilled piers. Provide detailed project specific information in this plan including:

1. Work experience in accordance with Section 1.0, Item B.
2. List and size of equipment including: cranes, kelly bars, drill rigs, vibratory hammers, augers, core barrels, cleanout buckets, airlifts and/or submersible pumps, tremies and/or concrete pumps, casing (diameters, thicknesses and lengths), desanding equipment (for slurry construction), etc.
3. Details of order of drilled pier construction.
4. Details of pier excavation methods.
5. Details of methods to clean the pier excavation bottom.
6. Details of reinforcement placement including support and method to center in the excavation.
7. Details of concrete placement including how the tremie or pump will be controlled during concrete placement and what type of discharge control will be used to prevent concrete contamination when the tremie or pump is initially placed in the excavation.
8. Details of casing installation and temporary casing removal including order of telescoped casing removal.
9. Required submittals for concrete mix designs.
10. Details of the slurry to be used (if applicable), including: product information, manufacturers mixing instructions, slurry equipment information and how the Contractor proposes to use the slurry. Also, submit a written approval from the slurry supplier that the water to be used is acceptable.
11. Details on the handling of drilling spoils and slurry overflow including environmental control procedures to be used to prevent the loss of concrete, slurry and spoils.
12. Details of how the slurry level will be maintained above the highest piezometric head (if applicable).
13. Other information shown on the plans or requested by the Engineer.

The Engineer reviews the drilled pier construction sequence plan for conformance with the plans, specifications and this special provision. Within 15 days of receiving the

plan, the Engineer notifies the Contractor of any additional information required and/or changes necessary to satisfy the plans, specifications and this special provision. Submit changes for re-evaluation of any unsatisfactory part of the construction sequence plan that is rejected. The Engineer will respond to the Contractor within 7 days after receiving the proposed changes.

If any changes in the procedure are made during the construction of the drilled piers, inform the Engineer in writing and await approval of the proposed modifications prior to the construction of the remaining drilled piers.

D. Preconstruction Meeting

Conduct a drilled pier preconstruction meeting with the Drilling Superintendent, the Resident or Bridge Maintenance Engineer and/or his or her representatives, the Bridge Construction Engineer and the Geotechnical Operations Engineer to discuss construction and inspection of the drilled piers. This meeting should occur after the Drilled Pier Contractor/Subcontractor has mobilized to the site and the construction sequence plan has been approved.

E. Definition of Rock

For the purposes of this special provision, "Rock" is defined as a continuous intact natural material in which the penetration rate with a rock auger is less than 2 inches (50 mm) per 5 minutes of drilling at full crowd force. This definition excludes discontinuous loose natural materials such as boulders and man-made materials such as concrete, steel, timber, etc. This definition of rock is not for pay purposes; see Section 8.0 for method of measurement of "Drilled Piers Not in Soil".

F. Rock Socket

When required by a note on plans, provide a minimum penetration into rock as directed by the Engineer.

2.0 EXCAVATION

Perform the excavations required for the drilled piers to the dimensions and elevations shown on the plans or otherwise required by the Engineer, including any miscellaneous grading or excavation to install the pier.

Excavate with a drill rig of adequate capacity. Use a rig that is capable of drilling through soil and non-soil including rock, boulders, timbers, man-made objects and any other materials encountered. Blasting is not permitted to advance the excavation. Blasting for core removal is only permitted when approved by the Engineer.

Use a drill rig capable of drilling a minimum of 25% deeper than the deepest drilled pier shown on the plans. Use drilling tools equipped with vents designed to stabilize the hydrostatic pressure above and below the tool during extraction from the excavation. For drilled piers constructed with slurry, monitor the rate at which the drilling tools are inserted

and extracted so as to minimize sidewall suction action in the excavation. Drilling below the tip elevations shown on the plans may be required to achieve adequate bearing.

A drilling log including information such as top and bottom elevation of each stratum encountered, drilling tools used, drilling time in each stratum and material descriptions of each soil and rock layer must be signed by the Contractor upon completion of each pier.

Dispose of drilling spoils in accordance with Section 802 of the Standard Specifications and as directed by the Engineer. Drilling spoils consist of all excavated material including water removed from the excavation either by pumping or drilling tools. Construct drilled piers at the locations shown on the plans and within the tolerances specified herein. If tolerances are exceeded, the Engineer may require corrective measures to meet the tolerances specified. Construct the drilled piers such that the axis at the top of the piers is no more than 3 inches (75 mm) in any direction from the position shown in the plans. Build drilled piers within 2% of the plumb deviation for the total length of the piers. Verify the plumbness of the drilled pier excavations by an accurate procedure, such as an inclinometer on the kelly bar or other approved techniques. Unless a plan note requires the construction joint to be moved below the ground line, construct the finished top of pier elevation between 1 inch (25 mm) above and 3 inches (75 mm) below the top of pier elevation shown on the plans.

When drilling from a barge, use a fixed template that maintains pier position and alignment during all excavation and concrete placement operations. Floating templates (attached to a barge) are not allowed unless approved by the Engineer.

Stabilize all drilled pier excavations with steel casing and/or slurry except, as approved by the Engineer, the portions of the excavations in rock as defined by Section 1.0, Item E. Stabilize excavations at all times from the beginning of drilling through concrete placement. When using multiple casings in a telescoped arrangement, overlap subsequent casings a minimum of 2 feet (600 mm). Provide casing or slurry in rock if unstable material is anticipated or encountered during drilling. When slurry is used, a partially excavated pier is subject to the time requirements in Section 2.0, Item C, Number 1. When slurry is not used, do not leave a drilled pier excavation open overnight unless it is cased to rock.

If a note on plans does not prohibit dewatering and the tip of the drilled pier excavation is in rock as defined by Section 1.0, Item E, dewater the excavation to the satisfaction of the Engineer. The minimum diameter of a drilled pier excavation in rock or an excavation constructed with slurry may be 2 inches (50 mm) less than the design drilled pier diameter shown on the plans.

In order to remove a casing and substitute a larger diameter or longer casing through unstable or caving material, either backfill the excavation, stabilize the excavation with slurry before removing the casing to be replaced or insert the larger casing around the casing to be replaced before removal.

A. Permanent Steel Casing

Use permanent steel casings as directed by the Engineer and/or as required by a note on plans. Use permanent casings that are clean smooth non-corrugated watertight steel of ample strength to withstand handling and driving stresses and the pressures imposed by concrete, earth or backfill. Provide permanent steel casings conforming to ASTM A252, Grade 2 and the following minimum wall thickness requirements.

CASING WALL THICKNESS

Casing Diameter	Minimum Wall Thickness
Less than or equal to 48 inches (1220 mm)	3/8 inch (9 mm)
Greater than 48 inches (1220 mm) and less than or equal to 78 inches (1982 mm)	1/2 inch (12 mm)
Greater than 78 inches (1982 mm)	5/8 inch (16 mm)

Provide permanent casings with an outside diameter not less than the specified size of the drilled pier. If approved by the Engineer, a permanent casing larger in diameter than the drilled pier design diameter is permitted. However, no payment will be made for any costs associated with larger permanent casings. Extend the permanent casings from the top of pier elevation or top of permanent casing elevation, if shown on the plans, to a depth no deeper than the permanent casing tip elevation shown on the plans or the revised permanent casing tip elevation approved by the Engineer. Do not extend permanent casings below the permanent casing tip elevation shown on the plans without prior approval from the Engineer. Additional drilled pier length and reinforcement may be required if permanent casings are extended below the permanent casing tip elevation shown on the plans. No payment will be made for the resulting additional drilled pier length, reinforcement and permanent casing unless the Engineer approves the revised permanent casing tip elevation. Install permanent casings in one continuous unit. If splices are necessary for the casing, use an approved method of splicing. Splices are considered incidental and no additional compensation will be made.

Remove any portion of the permanent steel casing that extends above the top of the drilled pier after the Drilled Pier Concrete has achieved a compressive strength of 4500 psi (31.0 MPa). The cost of casing removal will be considered incidental to the cost of the permanent steel casing.

B. Temporary Steel Casing

Provide temporary steel casing to stabilize drilled pier excavations, protect personnel and prevent caving or sloughing, that is clean smooth non-corrugated watertight steel of ample strength to withstand handling and driving stresses and the pressures imposed by concrete, earth or backfill. Use temporary steel casings with a minimum wall thickness of 3/8 inch (9 mm) and an outside diameter not less than the specified size of the drilled pier.

Temporary steel casings that become bound or fouled during construction and cannot be practically removed may constitute a defect in the drilled pier. Improve defective piers to the satisfaction of the Engineer by removing the concrete and extending the pier deeper, providing a replacement drilled pier or other acceptable means. Complete all corrective measures including any additional design work to the satisfaction of the Engineer without additional compensation or an extension of the completion date of the project.

C. Slurry

When slurry use is not noted on the plans, slurry construction is an option. If slurry use is required or an option, polymer slurry use may either be required or prohibited as noted on the plans. If slurry use is required or an option and polymer slurry use is not noted on the plans, polymer slurry use is an option.

If polymer slurry is required or an option, use one of the following polymers listed in the table below:

PRODUCT	MANUFACTURER
SlurryPro EXL	KB Technologies Ltd. 3648 FM 1960 West, Suite 107 Houston, TX 77068 (800) 525-5237
Super Mud	PDS Company 105 West Sharp Street El Dorado, AR 71730 (800) 243-7455
Shore Pac GCV	CETCO Drilling Products Group 1500 West Shure Drive Arlington Heights, IL 60004 (800) 527-9948

Use polymer slurry and associated additives in accordance with the manufacturer's guidelines and recommendations unless otherwise approved by the Engineer. The Contractor should be aware that polymer slurry might not be appropriate for a given site. Polymer slurry should not be used for excavations in soft or loose soils as determined by the Engineer. When using polymer slurry, a representative of the manufacturer must be on-site to assist and guide the Contractor during the construction of the first three drilled piers unless otherwise approved by the Engineer. This representative must also be available for on-site assistance to the Contractor if problems are encountered during the construction of the remaining drilled piers as requested by the Engineer. The cost of all on-site assistance and representation will be considered incidental to the cost of the drilled piers.

If mineral slurry is required or an option, use mineral slurry composed of bentonite having a mineral grain size that remains in suspension and sufficient viscosity and gel

characteristics to transport excavated material to a suitable screening system to minimize bottom sedimentation. Provide bentonite slurry to maintain the stability of the excavation and allow for proper concrete placement.

When slurry is used and permanent steel casing is not required, use temporary casing a minimum of 10 feet (3 m) long at the top of the excavation. Maintain the top of the temporary casing a minimum of 1 foot (300 mm) above the ground surface surrounding the casing.

Maintain the slurry in the pier excavation at a level not less than 5 feet (1.5 m) or the drilled pier diameter (whichever is greater) above the highest piezometric head along the depth of the pier. It is anticipated that the highest piezometric head is the static water or groundwater elevation (elevation head). However, the Contractor is responsible for determining the highest piezometric head. The use of steel casing to maintain the required slurry level is permitted; however, no payment will be made for casing that is used for this purpose. If the slurry level in the excavation suddenly changes or cannot be practically maintained, or the slurry construction method does not produce the desired result, stop the pier construction until an alternate construction procedure is approved by the Engineer.

Thoroughly premix the slurry with water in tanks before introducing the slurry into the excavation. Submit written approval from the slurry supplier that the mixing water is acceptable. Allow bentonite slurry to hydrate 24 hours in tanks before use. Slurry tanks of adequate capacity are required for slurry circulation, storage and treatment. Excavated slurry pits are not allowed in lieu of slurry tanks without prior approval from the Engineer. Take all steps necessary to prevent the slurry from "setting up" in the excavation. Such methods include, but are not limited to agitation, circulation and/or adjusting the properties of the slurry. Perform desanding operations as necessary to achieve the acceptable sand contents prior to placement of the reinforcing steel.

1. Time

Adjust the excavation operations so that the maximum time the slurry is in contact with the sidewalls of the uncased portions of the drilled pier excavation (from time of drilling to concrete placement) does not exceed 36 hours. Do not work on more than two drilled piers per drill rig below the steel casing at any time.

Agitate bentonite slurry in the drilled pier excavations a minimum of every 4 hours. If the bentonite slurry is not agitated a minimum of every 4 hours or the 36 hour time limit is exceeded, the Engineer may require the Contractor to overream the drilled pier excavation beneath the steel casing a minimum of 1 inch (25 mm) and a maximum of 3 inches (75 mm) before performing any other operations in the excavation. Overream with a grooving tool, overreaming bucket or other approved equipment at a minimum spacing of 12 inches (300 mm). All costs associated with both overreaming and the resulting additional concrete placement will be considered incidental to the cost of the drilled piers.

If concrete placement is not completed within three days of beginning drilling, enlarge the design drilled pier diameter by a minimum of 6 inches (150 mm), or as required by the Engineer, the entire length of the pier at no additional cost to the Department. Enlarging the drilled pier includes replacing the steel casing with steel casing the same size to which the drilled pier is enlarged at no additional cost to the Department.

2. Sampling

Collect all slurry samples using an approved sampling tool. Test slurry samples to determine density, viscosity, pH and sand content to establish an acceptable working pattern during slurry use. Test a minimum of four samples during each 8 hours of slurry use for each drilled pier. Take the first sample for the first 8 hours from the slurry tank prior to introduction into the pier excavation. Collect the remaining samples from the bottom of the drilled pier excavation. When the test results are acceptable and consistent, a decrease in the testing frequency to one sample per 4 hours of slurry use is permitted.

Prior to placing the reinforcing steel in any drilled pier excavation, extract slurry samples from the bottom of each pier excavation and at intervals not exceeding 10 feet (3 m) up the pier, until two consecutive samples produce acceptable values for density, viscosity, pH and sand content.

3. Testing

Have qualified personnel, approved by the Engineer, conduct slurry tests to determine density, viscosity, pH and sand content. The following tables show the acceptable range of values for the slurry properties:

BENTONITE SLURRY Sodium Montmorillonite (Commercial Bentonite) Acceptable Range of Values			
Property (units)	At Time of Slurry Introduction	In Excavation Immediately Before Concrete Placement	Test Method
Density, pcf (kg/m ³)	64.3 – 69.1 (1030- 1107)	64.3 – 75.0 (1030- 1201)	Mud Weight (Density) API 13B-1 Section 1
Viscosity, sec./quart (sec./0.95 liters)	28 – 45	28 – 45	Marsh Funnel and Cup API 13B-1 Section 2.2
PH	8 – 11	8 – 11	pH paper
Sand Content (percent)	Less than or equal to 4	Less than or equal to 2	Sand API 13B-1 Section 5
Notes:			
1. Perform tests when the slurry temperature is above 40°F (4.4°C).			
2. When approved by the Engineer for use in saltwater, increase the density by 2 pcf (32 kg/m ³).			

SLURRYPRO EXL KB Technologies Ltd. Acceptable Range of Values			
Property (units)	At Time of Slurry Introduction	In Excavation Immediately Before Concrete Placement	Test Method
Density, pcf (kg/m ³)	Less than or equal to 67 (1073)	Less than or equal to 64 (1025)	Mud Weight (Density) API 13B-1 Section 1
Viscosity, sec./quart (sec./0.95 liters)	53 – 127	Less than or equal to 74	Marsh Funnel and Cup API 13B-1 Section 2.2
PH	8 – 11	8 – 11	pH paper
Sand Content (percent)	Less than or equal to 1	Less than or equal to 1	Sand API 13B-1 Section 5
Notes:			
1. Perform tests when the slurry temperature is above 40°F (4.4°C).			
2. When approved by the Engineer for use in saltwater, increase the density by 2 pcf (32 kg/m ³).			

SUPER MUD PDS Company Acceptable Range of Values			
Property (units)	At Time of Slurry Introduction	In Excavation Immediately Before Concrete Placement	Test Method
Density, pcf (kg/m ³)	Less than or equal to 64 (1025)	Less than or equal to 64 (1025)	Mud Weight (Density) API 13B-1 Section 1
Viscosity, sec./quart (sec./0.95 liters)	34 – 64	Less than or equal to 64	Marsh Funnel and Cup API 13B-1 Section 2.2
PH	8 – 10	8 – 10	pH paper
Sand Content (percent)	Less than or equal to 1	Less than or equal to 1	Sand API 13B-1 Section 5
Notes:			
1. Perform tests when the slurry temperature is above 40°F (4.4°C).			
2. When approved by the Engineer for use in saltwater, increase the density by 2 pcf (32 kg/m ³).			

SHORE PAC GCV CETCO Drilling Products Group Acceptable Range of Values			
Property (units)	At Time of Slurry Introduction	In Excavation Immediately Before Concrete Placement	Test Method
Density, pcf (kg/m ³)	Less than or equal to 64 (1025)	Less than or equal to 64 (1025)	Mud Weight (Density) API 13B-1 Section 1
Viscosity, sec./quart (sec./0.95 liters)	35 – 78	Less than or equal to 60	Marsh Funnel and Cup API 13B-1 Section 2.2
PH	8 – 11	8 – 11	pH paper
Sand Content (percent)	Less than or equal to 1	Less than or equal to 1	Sand API 13B-1 Section 5
Notes:			
1. Perform tests when the slurry temperature is above 40°F (4.4°C).			
2. When approved by the Engineer for use in saltwater, increase the density by 2 pcf (32 kg/m ³).			

When any slurry samples are found to be unacceptable, take whatever action is necessary to bring the slurry within specification requirements. Do not place reinforcement steel until resampling and testing produce acceptable results.

Sign and submit reports of all slurry tests required above to the Engineer upon completion of each drilled pier. The Department reserves the right to perform comparison slurry tests at any time.

4. Slurry Disposal

Comply with all applicable local, state and federal regulations, as well as with the environmental permits of the project when disposing of excavated materials contaminated with slurry. Keep all excavated materials, spoils from the desanding unit and slurry out of the water and contain them at all times. The cost of the containment, removal and disposal of excavated materials contaminated with slurry, as well as the slurry itself, is incidental to the cost of the drilled piers.

3.0 CLEANING

Excavate the bottom of the drilled pier to a level plane or stepped with a maximum step height of 12 inches (300 mm). Regardless of construction methods used, clean the bottom of the excavation of loose material using a technique approved by the Engineer. When the drilled pier excavation is not hand cleaned, clean the bottom of the excavation with a cleanout bucket and an airlift or submersible pump.

4.0 INSPECTION METHODS AND REQUIREMENTS

After the drilled pier excavation is complete and immediately prior to placement of the reinforcing steel and concrete, demonstrate the proper condition of the drilled pier excavation to the Engineer for verification. Provide bosun chairs, gas meters, safety equipment, lights, mirrors, weighted tape measures, steel probes, personnel and all assistance required for the Engineer to inspect the drilled pier excavations.

A. Bearing Capacity

One or more of the following tests may be used to verify the conditions and continuity of the bearing material prior to placement of the reinforcing steel. If the required end bearing capacity is not satisfied, increase the drilled pier length as directed by the Engineer. Payment for the additional length of the drilled pier to achieve adequate bearing will be made per the drilled pier pay items.

1. Visual Inspection

The end bearing of the drilled pier excavation may be inspected either by entering the excavation or visually from the top of the excavation.

2. Test Hole

If the tip of the drilled pier excavation is in rock as defined by Section 1.0, Item E, drill a 1½ inch (38 mm) diameter test hole in each drilled pier to a depth at least 6 feet (1.83 m) below the tip elevation.

3. Standard Penetration Test (SPT)

When noted on the plans that a SPT is required, drive a split barrel sampler a minimum of 18 inches (450 mm) below the drilled pier tip elevation or to refusal in accordance with ASTM D1586. Complete the SPT using NW rods through casing or another stabilizing method as approved by the Engineer. Extend the SPT rods from the top of the drilled pier excavation to the drilled pier tip elevation. Firmly support the SPT casing at the top of the drilled pier excavation and rest it on the bottom of the excavation. Conduct the SPT a minimum of 12 inches (300 mm) away from the sidewalls of the excavation and be sure not to scrape the sidewalls of the excavation while inserting or withdrawing the SPT equipment. Have the SPT device on-site prior to reaching the drilled pier tip elevation. Report the number of blows needed to drive the split barrel sampler and a description of the recovered

soil sample to the Engineer. The Engineer determines the number of blows required for bearing.

B. Bottom Cleanliness

One or more of the following inspection procedures may be used to inspect the cleanliness of the pier excavation bottom prior to placement of the reinforcement steel and concrete.

The pier excavation bottom is considered clean if a minimum of 50% of the bottom area has less than ½ inch (13 mm) of sediment and no portion of the bottom area has more than 1½ inches (38 mm) of sediment as determined by the Engineer.

1. Visual Inspection

The cleanliness of the drilled pier excavation bottom may be observed either by entering the excavation or from the top of the excavation.

2. Steel Probe

If the excavation is not dewatered or if the Engineer requires it, lower a steel probe to the bottom of the drilled pier excavation to ensure that cleaning has been satisfactorily completed. Supply a steel probe that is 2 feet (0.6 m) long with a flat tip on the sounding end, weighs approximately 9 pounds (#10 rebar) (4 kg, #32 rebar) and is suspended from the opposite end with a non-stretch cable.

3. Shaft Inspection Device (SID)

The Department may use the SID to take sediment measurements and observe the bottom conditions of the drilled pier excavation at a minimum of five locations selected by the Engineer. The SID is a remotely operated camera capable of observing bottom conditions and measuring sediment underwater and slurry. Each SID inspection (including all 5 locations) takes approximately 1 hour after the equipment has been set up. The Engineer provides the SID and the personnel to operate the device. Notify the Engineer a minimum of 2 days prior to beginning the drilled pier excavation so the Engineer can arrange for the transportation of the SID to the site and the personnel to perform the inspections. SID inspections are required until the cleanliness of the drilled pier excavation bottom is acceptable in accordance with Section 4.0, Item B of this special provision. Do not conduct operations that interfere with the SID inspections as directed by the Engineer. Remove all cleaning and drilling equipment from the drilled pier excavation during any SID inspection. Provide a working area large enough for the SID equipment, within the reach of the cabling supplied, and within clear sight distance of the drilled pier excavation, as directed by the Engineer. Assist the Engineer in the transportation and handling of the SID and all the associated equipment and in supporting the electric hoist and/or hoisting tripod for the SID, as directed by the Engineer. If required, provide a safe and secure location to park the trailer for the SID while it is unattended on the project site. If any of the SID equipment is

damaged due to the Contractor's negligence, then replace the equipment at no additional cost to the Department. Provide replacement equipment that exactly matches the damaged equipment as directed by the Engineer. All costs involved with the initial SID inspection of each drilled pier excavation will be made per the SID pay item. No additional payment will be made for subsequent or repeated SID inspections of the same drilled pier excavation. No claims for either lost time or actual expense of any SID inspections that do not find the cleanliness of the drilled pier excavation bottom in compliance with this special provision will be paid.

5.0 REINFORCING STEEL

Completely assemble a cage of reinforcing steel, consisting of longitudinal and spiral bars and place it in the drilled pier excavation as a unit immediately after the proper condition of the excavation is demonstrated to the Engineer. When concrete placement does not follow immediately after cage placement, remove the steel from the pier excavation unless the Engineer directs otherwise. If the cage is removed, recheck pier excavation cleanliness in accordance with this special provision prior to reinstallation of the cage.

If the drilled pier excavation is cased down to rock, immediate placement of the reinforcing steel and the concrete is not required. If electing to delay placement of the reinforcing steel and concrete due to the presence of rock, recheck the excavation for proper cleanliness immediately prior to placement of the reinforcing steel.

A. Construction, Placement, Support and Alignment

If it is determined in the field that the drilled pier must be longer, adequate reinforcement may be required in the extended length as directed by the Engineer. Lift the cage so racking and cage distortion does not occur. Keep the cage plumb during concrete operations and casing extraction. Check the position of the cage before and after placing the concrete. Position the splice length of the drilled pier cage so that the column or footing has the minimum concrete cover shown on the plans.

Securely cross-tie the vertical and spiral reinforcement at each intersection with double wire. Support or hold down the cage so that the vertical displacement during concrete placement and casing extraction does not exceed 6 inches (150 mm).

B. Bolsters and Spacers

Set the rebar cage directly on the bottom of the drilled pier excavation with plastic bolsters under each vertical reinforcing bar. Ensure that spacers are tall enough to raise the rebar cage off the bottom of the drilled pier excavation a minimum of 3 inches (75 mm). If approved by the Engineer, the rebar cage may be hung in the excavation provided the mechanisms supporting the cage are left in place until the Drilled Pier Concrete strength has achieved 3000 psi (20.7 MPa).

In order to ensure the minimum required concrete cover and achieve concentric spacing of the cage within the pier, attach plastic spacer wheels at five points around the cage perimeter. Use spacer wheels that provide a minimum of 4 inches (100 mm)

"blocking" from the outside face of the spiral bars to the outermost surface of the drilled pier except in rock as defined by Section 1.0, Item E and when using slurry construction. Use spacer wheels for slurry construction or in rock that provide a minimum of 2 inches (50 mm) "blocking". Tie spacer wheels that snap together with wire and allow them to rotate. Use spacer wheels that span at least two adjacent vertical bars. Start placing spacer wheels at the bottom of the cage and continue up along its length at maximum 10 foot (3 m) intervals.

6.0 CONCRETE

Begin concrete placement immediately after inserting reinforcing steel into the drilled pier excavation. Prior to placing concrete, assure the Engineer that sufficient quantities of concrete are available and that sufficient transportation is committed to the project to deliver the concrete within the time frame set forth within this special provision.

A. Concrete Mix

Provide the mix design for Drilled Pier Concrete for approval and, except as modified herein, meeting the requirements of Section 1000 of the Standard Specifications.

Designate the concrete as Drilled Pier Concrete with a minimum compressive strength of 4500 psi (31.0 MPa) at 28 days. Use a mix that complies with one of the following:

- Type I or II cement with a minimum cement content of 640 lbs/yd³ (380 kg/m³) and a maximum cement content of 800 lbs/yd³ (475 kg/m³).
- Type IP blended cement with a minimum cement content of 665 lbs/yd³ (395 kg/m³) and a maximum cement content of 833 lbs/yd³ (494 kg/m³).

Limit the water cement ratio based on total cementitious materials to a maximum of 0.45. Air-entrainment is not required. Air content should be less than 7.5%.

Produce a workable mix so that vibrating or prodding is not required to consolidate the concrete. When placing concrete, the slump must be 5 to 7 inches (125 to 175 mm) for dry placement and 7 to 9 inches (175 to 225 mm) for wet placement.

Use No. 78M coarse aggregate in the mix. Use an approved water-reducer, water-reducing retarder, high-range water-reducer or high-range water-reducing retarder to facilitate placement of the concrete if necessary. Do not use a stabilizing admixture as a retarder in Drilled Pier Concrete without approval of the Engineer. Use admixtures that satisfy AASHTO M194 and add them at the concrete plant when the mixing water is introduced into the concrete. Redosing of admixtures is not permitted. Ensure that the concrete temperature at the time of placement is 90°F (32°C) or less.

B. Concrete Placement

Place concrete such that the drilled pier is a monolithic structure. Vibration is only permitted, if needed, in the top 10 feet (3 m) of the drilled pier or as directed by the Engineer. Remove any contaminated concrete from the top of the drilled pier at the

time of concrete placement. Contain and remove all wasted concrete that spills over the casing.

Do not twist, move or otherwise disturb temporary casings until the concrete depth in the casing is in excess of 10 feet (3 m) above the bottom of the casing being disturbed. If the head is greater than 30 feet (9 m), the Engineer may require a concrete depth greater than 10 feet (3 m). The head is defined as the difference between the highest piezometric head along the depth of the pier and the static water elevation inside the excavation. If the Engineer requires a concrete depth greater than 10 feet (3 m), the Contractor may choose to either place concrete with this required concrete depth or place concrete with the wet method and a minimum concrete depth of 10 feet (3 m).

Maintain the required concrete depth above the bottom of the innermost casing during casing removal, except when the concrete level is at or above the top of drilled pier elevation. Sustain a sufficient concrete depth above the bottom of casing to overcome outside soil and water pressure. As the casing is withdrawn, exercise care in maintaining an adequate concrete depth within the casing so that fluid trapped behind the casing is displaced upward and discharged at the ground surface without contaminating or displacing the Drilled Pier Concrete. Exerting downward pressure, hammering and/or vibrating the temporary casing is permitted to facilitate removal.

Use the water inflow rate to determine the concrete placement procedure after any pumps have been removed from the excavation. If the inflow rate is less than 6 inches (150 mm) per half hour, the concrete placement is considered dry. If the water inflow rate is greater than 6 inches (150 mm) per half hour, the concrete placement is considered wet.

Keep a record of the volume of concrete placed in each drilled pier excavation and make it available to the Engineer. For drilled piers constructed with slurry or as directed by the Engineer, record a graphical plot of the depth versus theoretical concrete volume and actual measured concrete volume for each drilled pier and provide it to the Engineer when finished placing concrete.

1. Dry Placement

Before concrete placement, make certain the drilled pier excavation is dry so the flow of concrete around the reinforcing steel can be verified by visual inspection. If the concrete free fall does not exceed 60 feet (18.3 m), placing the concrete by a central drop method where the concrete is chuted directly down the center of the excavation is permitted.

For drilled piers exceeding 60 feet (18.3 m) in length, use a tremie or a pump to place concrete unless otherwise approved by the Engineer. Support the tremie or pump pipe so that the concrete free fall is less than 60 feet (18.3 m) at all times.

2. Wet Placement

Maintain a static water or slurry level in the excavation prior to placing concrete underwater. When temporary casing is used as the method to stabilize the excavation, place concrete with a sectional tremie or pump (no continuous tremie).

Once the concrete in the excavation reaches the same elevation as the static water level, placing concrete with the dry method is permitted. Before changing to the dry method of concrete placement, remove the water above the concrete and clean the concrete surface of all scum and sediment to expose clean, uncontaminated concrete.

3. Tremie and Pump

Place concrete with a tremie and/or a pump in accordance with the applicable parts of Sections 420-6 and 420-8 of the Standard Specifications that concern tremie and/or concrete pumping operations. Use a tremie a minimum of 10 inches (254 mm) in diameter unless otherwise approved by the Engineer. Use a tremie tube or pump pipe made of steel with watertight joints. Use a discharge control to prevent concrete contamination when the tremie tube or pump pipe is initially placed in the excavation. Extend the tremie tube or pump pipe into the concrete a minimum of 5 feet (1.5 m) at all times except when the concrete is initially introduced into the pier excavation. If the tremie tube or pump pipe pulls out of the concrete for any reason after the initial concrete is placed, restart concrete placement with a steel capped tremie tube or pump pipe.

4. Placement Time

Place concrete within the time frames specified in Table 1000-2 of the Standard Specifications for Class AA concrete and this special provision. Do not place concrete so fast as to trap air, slurry, water, fluids, soil or any other deleterious materials in the vicinity of the reinforcing steel and the annular zone between the rebar cage and the excavation walls.

7.0 SCHEDULING AND RESTRICTIONS

After the first drilled pier is successfully completed, do not make any significant changes in construction methods, equipment or materials, unless approved by the Engineer.

If caving or sloughing occurs, compensation will not be provided for additional concrete to fill the resulting voids.

For the first 16 hours after a drilled pier has achieved its initial concrete set (as determined by the Engineer), do not drill adjacent piers, do not install adjacent piles, and do not allow any equipment wheel loads or "excessive" vibrations within 20 feet (6 m) of the drilled pier.

In the event that the procedures described herein are performed unsatisfactorily, the Engineer reserves the right to shut down the construction operations. If the integrity of the drilled pier is in question, the Engineer reserves the right to reject the drilled piers and require remediation. Remedial measures are proposed by the Contractor and require approval of the Engineer. No compensation will be paid for losses or damage due to remedial work or any investigation of drilled piers found defective or not in accordance with this special provision or the plans.

8.0 MEASUREMENT AND PAYMENT

A. Method of Measurement

1. Drilled Piers in Soil

The quantity of "Drilled Piers in Soil" to be paid for will be the linear feet (meters) of the drilled piers exclusive of the linear feet (meters) of "Drilled Piers Not in Soil" computed from elevations and dimensions as shown on the plans or from revised dimensions authorized by the Engineer. Drilled piers through air or water will be paid for as "Drilled Piers in Soil".

2. Drilled Piers Not in Soil

The quantity of "Drilled Piers Not in Soil" to be paid for will be the linear feet (meters) of drilled piers excavated in non-soil as determined by the Engineer. Non-soil is defined as material that can not be cut with a rock auger and requires excavation by coring, air tools, hand removal or other acceptable methods. Top of non-soil elevation is that elevation where the rock auger penetration rate is less than 2 inches (50 mm) per 5 minutes of drilling at full crowd force and coring, air tools, etc. are used to advance the excavation. For pay purposes, after non-soil is encountered, earth seams, rock fragments and voids in the excavation less than 3 feet (0.9 m) in total length will be considered "Drilled Piers Not in Soil". If the non-soil is discontinuous, payment will revert to "Drilled Piers in Soil" at the elevation where non-soil is no longer encountered.

3. Permanent Steel Casing

The quantity of "Permanent Steel Casing" to be paid for will be the linear feet (meters) of permanent steel casing as directed or required to be used. The length to be paid for will be measured along the permanent casing from the top of the casing elevation or top of the pier elevation, whichever is lower, to the permanent casing tip elevation. The Department will also pay for up to an additional 3 feet (1 m) of permanent casing cut off if the casing can not be installed to the permanent casing tip elevation shown on the plans. Permanent casing will be paid for only when permanent casing is authorized or when the Engineer directs the Contractor to leave a casing in place such that it becomes a permanent part of the pier. No payment will be made for temporary steel casings that become bound or fouled during pier construction and cannot be practically removed.

4. Shaft Inspection Device (SID)

The quantity of "SID Inspection" to be paid for will be per drilled pier as noted on the plans and/or directed by the Engineer. SID inspections are performed until the bottom cleanliness of the drilled pier excavation is acceptable by this special provision; however, payment will only be made for the initial SID inspection of each drilled pier excavation.

5. Standard Penetration Test (SPT)

The quantity of "SPT Testing" to be paid for will be the actual number of SPT tests performed as noted on the plans and/or directed by the Engineer.

B. Basis of Payment

1. Drilled Piers in Soil

Payment will be made at the contract unit price per linear foot (meter) for "____ Dia. Drilled Piers in Soil". Such payment will include, but is not limited to, furnishing all labor, tools, equipment, materials including concrete complete and in place and all incidentals necessary to excavate the drilled piers and complete the work as described in this special provision. No additional payment will be made for slurry use. No additional payment will be made for any miscellaneous grading or excavation to install the drilled pier. "Reinforcing Steel" and "Spiral Column Reinforcing Steel" will be paid for separately and will not be part of the unit bid price for "Drilled Piers in Soil".

2. Drilled Piers Not in Soil

Payment will be made at the contract unit price per linear foot (meter) for "____ Dia. Drilled Piers Not in Soil". Such payment will include, but is not limited to, furnishing all labor, tools, equipment, materials including concrete complete and in place and all incidentals necessary to excavate the drilled piers and complete the work as described in this special provision. No additional payment will be made for slurry use. No additional payment will be made for any miscellaneous grading or excavation to install the drilled pier. "Reinforcing Steel" and "Spiral Column Reinforcing Steel" will be paid for separately and will not be part of the unit bid price for "Drilled Piers Not in Soil".

3. Permanent Steel Casing

Payment will be made at the contract unit price per linear foot (meter) for "Permanent Steel Casing for ____ Dia. Drilled Pier". Such payment will include, but is not limited to, furnishing all material, labor, tools, equipment and all incidentals necessary to install the casing in the pier excavation.

4. Shaft Inspection Device (SID)

Payment for SID will be at the contract unit price per each for "SID Inspection". Such payment will include, but is not limited to, furnishing all materials, labor, tools, equipment and all incidentals necessary to complete the SID inspection as described in this special provision.

5. Standard Penetration Test (SPT)

Payment for SPT will be at the contract unit price per each for "SPT Testing". Such payment will include, but is not limited to, furnishing all materials, labor, tools, equipment and all incidentals necessary to complete the SPT at each test location.

CROSSHOLE SONIC LOGGING

(6-7-05)

1.0 GENERAL

Use the non-destructive testing method called Crosshole Sonic Logging (CSL) to verify the integrity of the drilled pier and the quality of the concrete. The Engineer will determine the number of CSL tests and which drilled piers will be CSL tested. Drilled piers are referred to as piers in this special provision.

The CSL test measures the time for an ultrasonic pulse to travel from a signal source in one access tube to a receiver in another access tube. In uniform, good quality concrete, the travel time between equidistant tubes should yield relatively consistent arrival times and correspond to a reasonable pulse velocity, signal amplitude and energy from the bottom to the top of the pier. Longer travel times, decrease in pulse velocity and lower amplitude/energy signals indicate the presence of irregularities such as poor quality concrete, voids, honeycombing, cracking and soil intrusions. The signal may be completely lost by the receiver and CSL recording system for severe defects such as voids and soil intrusions.

The CSL Consultant must have a minimum 3 years experience of CSL testing and have a Registered North Carolina Professional Engineer supervising the testing and interpretation of results. Submit the proposed CSL Consultant to the Engineer for approval 30 days before beginning drilled pier construction. The following evidence of qualification is required, unless the Department previously approved the consultant and no changes have occurred since previous submittal:

- Written evidence of successful completion of CSL tests, brief descriptions and reference's phone numbers for three recent CSL projects.
- Personnel qualifications
- Equipment description
- Example report

Make all necessary arrangements with the CSL Consultant to have the CSL tests satisfactorily performed on the selected drilled piers and in accordance with this special provision. The CSL Consultant must supply to the Contractor technical instruction and guidance in preconstruction activities and on-site technical assistance and guidance during set up and performance of the CSL tests. Provide suitable access to the site and to the top of piers to be tested. Follow instructions from the CSL Consultant unless the Engineer directs otherwise.

Place CSL tubes in all drilled piers. Perform CSL testing only on drilled piers selected by the Engineer a minimum 7 days after concrete placement and after concrete achieves a minimum compressive strength of 3000 psi (20.7 MPa), but within 30 days after concrete placement. After CSL test results have been reviewed and the Engineer has accepted the drilled pier or approves grouting of the tubes, dewater the tubes and core holes, if any, and backfill with an approved 4500 psi (31.0 MPa) compressive strength grout. If the Engineer elects not to CSL test a pier, obtain approval from the Engineer to dewater the tubes and backfill them with an approved grout.

2.0 PREPARATION FOR CSL

Submit to the Engineer the CSL tube size, the manufacturer's certificate of compliance, cap details, couplings, any joint details and the proposed method of attaching the tubes 30 days before beginning drilled pier construction.

Install four tubes in each drilled pier with a diameter of 5 feet (1524 mm) or less and six tubes in each pier with a diameter of greater than 5 feet (1524 mm). Provide 2 inch (50 mm) inside diameter Schedule 40 steel pipe conforming to ASTM A53, Grade A or B, Type E, F, or S. The tubes must have a round, regular internal diameter free of defects or obstructions, including any at tube joints, in order to permit the free, unobstructed passage of source and receiver probes. The tubes must provide a good bond with the concrete and be watertight.

Fit the tubes with a watertight threaded cap on the bottom and a removable threaded cap on the top. Securely attach the tubes to the interior of the reinforcement cage. Install the tubes in each drilled pier in a regular, symmetric pattern such that each tube is equally spaced from the others around the perimeter of the cage. Tube placement must be such that large vertical reinforcing bars do not block the direct line between adjacent tubes. The tubes are typically wire-tied to the reinforcing cage every 3 feet (1 m) or otherwise secured such that the tubes remain in position during placement of the rebar cage and the concrete. The tubes must be as near to vertical and as parallel as possible, **as non-vertical tubes can adversely affect data analysis**. Extend the tubes from 6 inches (150 mm) above the pier tip to at least 3 feet (1 m) above the top of the pier. If the pier top elevation is below ground elevation, extend tubes at least 2 feet (610 mm) above ground surface. If the drilled pier tip elevation is excavated more than 1 foot (305 mm) below the tip elevation shown on the plans, extend the tubes using proper threaded mechanical couplings to within 6 inches (150 mm) of the revised pier tip elevation.

Before placement of the reinforcement cage into the drilled pier, record the tube lengths and tube positions along the length of the cage. After concrete placement, measure the stickup of the tubes above the top of the drilled piers and verify tube spacing.

After placement of the reinforcement cage and before concrete placement, fill the CSL tubes with clean water and cap them to keep out debris. CSL tubes that are not filled with water and capped will be rejected. When removing the caps, use care not to apply excess torque, force or stress, which could break the bond between the tubes and the concrete.

Verify that unobstructed passage of the probes is achievable before the CSL Consultant arrives on site. If testing equipment will not pass through the entire length of the CSL tube, core a 2 inch (50 mm) diameter hole through the concrete the full length of the drilled pier at no cost to the Department. Locate the core hole approximately 9 inches (230 mm) inside the pier reinforcement from obstructed tube or as determined by the Engineer. Fill core hole with clean water and cover to keep out debris.

3.0 CSL EQUIPMENT

The minimum requirements of the CSL equipment are as follows:

- A microprocessor based CSL system for display of individual CSL records, analog-digital conversion and recording of CSL data, analysis of receiver responses and printing of report quality CSL logs
- Ultrasonic source and receiver probes which can travel through 2 inch (50 mm) I.D. steel pipe
- An ultrasonic voltage pulser to excite the source with a synchronized triggering system to start the recording system
- A depth measurement device to electronically measure and record the source and receiver depths associated with each CSL signal
- Appropriate filter/amplification and cable systems for CSL testing
- An acquisition system that stores each log in digital format, with drilled pier identification, date, time and test details, including the source and receiver gain. Arrival time data must be displayed graphically during data acquisition.
- 3D tomographic imaging software, or source for completing the work

4.0 CSL TEST PROCEDURE

Provide the Engineer and CSL Consultant with the following:

- Tube lengths and positions
- Record of the drilled pier construction information including the pier bottom and top elevations
- Construction dates before CSL testing

Conduct CSL tests between each perimeter pair and major principal diameter and log, unless otherwise directed by the Engineer.

Perform the CSL testing with the source and receiver probes in the same horizontal plane unless test results indicate defects or poor concrete zones, in which case the defect zones must be further evaluated with angle tests (source and receiver vertically offset at greater than 1.5 feet (460 mm) in the tubes). Report any defects indicated by decreased signal velocity and lower amplitude/energy signals to the Engineer at the time of testing and conduct angle tests in the zones of the defects as defined by the Concrete Condition Rating Criteria (CCRC) in Section 5.0 of this special provision. Make CSL measurements at depth intervals of 2 ½ inches (65 mm) or less from the bottom of the tubes to the top of each pier. Pull the probes simultaneously, starting from the bottom of the tubes, using a depth-measuring device to electronically measure and record the depths associated with each CSL signal. Remove any slack from the cables before pulling to provide for accurate depth measurements of the CSL records. In the event defects are detected, conduct additional logs, as needed, at no additional cost to the Department. The Department will not accept any claims for either lost time or the actual expense of further investigation of defects.

If steel tube debonding occurs, then core drill a 2 inch (50 mm) diameter hole to the depth of debonding for each debonded tube in order to perform the CSL logs at no additional cost to the Department.

5.0 CSL RESULTS AND REPORTING

Submit the CSL test results in both electronic and hard copy form including two original copies of CSL report to the Engineer within 5 working days of completion of CSL testing. The CSL report should include but not limited to the following:

- Project identification
- Dates of testing
- Table and a plan view of each pier tested with accurate identification of tube coordinates and tubes referenced to the site
- Tube collar elevation
- Names of personnel that performed the tests/interpretation and their affiliation
- Equipment used
- Interpretation, analysis and results

Include CSL logs for each tube pair tested with analysis of the initial pulse arrival time, velocity, relative pulse energy/amplitude and stacked waveform plotted versus depth. List all zones defined by the Concrete Condition Rating Criteria (CCRC) in a tabular format including the percent velocity reduction and the velocity values used from the nearby zone of good quality concrete. Discuss each zone defined by the CCRC in the CSL report as appropriate. Base the results on the percent reduction in velocity value from a nearby zone

of good quality concrete with good signal amplitude and energy as correlated to the following:

Concrete Condition Rating Criteria (CCRC)			
CCRC	Rating Symbol	Velocity Reduction	Indicative Results
Good	G	$\leq 10 \%$	Good quality concrete
Questionable Defect	Q	$>10 \%$ & $< 20 \%$	Minor concrete contamination or intrusion. Questionable quality concrete.
Poor	P/D	$\geq 20 \%$	Defects exist, possible water/slurry contamination, soil intrusion and/or poor quality concrete.
No Signal	NS	No Signal received	Soil intrusion or other severe defect absorbed the signal (assumes good bond of the tube-concrete interface).
Water	W	V = 4750 fps (1450 mps) to 5000 fps (1525 mps)	Water intrusion or water filled gravel intrusion with few or no fines present.

The following are a few examples of types and causes of defects:

- Necking or arching of the concrete on withdrawal of the temporary casing.
- Necking or contamination of the concrete due to collapse of the side walls.
- Soft toe due to incomplete cleaning or collapse of the side walls.
- Horizontal lenses of silt\mud\slurry due to the tremie pipe rising above the concrete.
- Voids due to the use of low-slump concrete.
- Honeycombing due to washout of fines.
- Trapping of contaminants due to pumping concrete too fast.

Provide the original pulse signal data files and ASCII format of the picks with a header (identifying the pier tested, tube coordinates and each data column) in an electronic file to the Engineer. The Engineer will require 5 working days to evaluate the CSL test results and determine whether or not the drilled pier is acceptable. Evaluation of CSL test results, with ratings other than good (G) per the Concrete Condition Rating Criteria (CCRC) may require further investigation and additional time for review and analysis of the data. Do not grout the CSL tubes or perform any further work on the CSL tested drilled pier until the Engineer determines whether the drilled pier is acceptable. Perform tomography in order to further investigate and delineate the boundaries of any defective/unconsolidated zones

with 20% or more reduction in velocity value as correlated to the CCRC. Process CSL data to construct easy to understand 2D/3D (2D cross-sections between tubes and 3D volumetric images for the entire pier) *color-coded* tomographic images indicating velocity variations along the pier. Location and geometry of defective/unconsolidated zones must be identified in 3D color images with detailed discussion in the CSL report. Any further tests deemed necessary by the Engineer in order to determine the acceptability of the drilled pier will be determined after reviewing the CSL report. Additional test or analysis options include 3D tomographic imaging, single-hole sonic testing, sonic echo or impact response tests and concrete coring.

The Engineer determines the depth, location, diameter (PQ or NQ size) and number of core holes when concrete coring is required. If the Engineer is concerned about concrete strength or requires the use of a borehole camera for inspection, large diameter cores (PQ size) are required. Drill a minimum of two core holes to intercept the suspected defect zones. Use a coring method that provides maximum core recovery and minimizes abrasion and erosion. Provide concrete cores properly marked in a wooden crate labeled with the drilled pier depth at each interval of core recovery to the NCDOT Materials and Test Unit for evaluation and testing. Submit to the Engineer coring records, signed by the Contractor, that include NCDOT project number, name of the Drilling Contractor, date cored and percent core recovery. Allow 5 working days after submitting the core records for the Department's review.

6.0 CORRECTION OF UNACCEPTABLE DRILLED PIER

When the Engineer determines a drilled pier is unacceptable, submit remedial measures to the Department for approval. No compensation will be made for remedial work or losses or damage due to remedial work of drilled piers found defective or not in accordance with the Drilled Piers Special Provision or the plans. Modifications to the drilled pier design or any load transfer mechanisms required by the remedial action must be designed by a Registered North Carolina Professional Engineer. Include supporting calculations and drawings sealed by a Registered North Carolina Professional Engineer for all foundation elements affected. Do not begin remedial action work until the Department has reviewed and accepted the remedial action plan. Allow 5 working days after submitting the remedial work plan for the Department's review and acceptance. Furnish all materials and work necessary to correct defective drilled piers.

7.0 MEASUREMENT AND PAYMENT

The complete and accepted CSL will be paid for at the unit bid price for "Crosshole Sonic Logging" per drilled pier. The Department will only pay for the initial CSL test on a drilled pier; no additional payment will be made for subsequent CSL tests performed on the same drilled pier. Include in this unit bid price all costs incurred for procurements, conducting the CSL testing, reporting of results and incidentals necessary to complete the work including any other test required to determine the acceptability of the drilled pier.

Include the cost of the crosshole sonic logging tubes in the unit bid price for drilled piers. No separate payment will be made for the CSL tubes. The unit bid price for the drilled

piers will include full compensation for furnishing, installing, extending tubes, dewatering and grouting of all CSL tubes and core holes, if applicable, and all materials, labor, tools, equipment and incidentals necessary to complete the work.

EPOXY PROTECTIVE COATING

(10-12-01)

1.0 DESCRIPTION

This work consists of preparing the concrete surface and furnishing and applying an epoxy protective coating to the surfaces described in this Special Provision. When epoxy protective coating is required, cure the top surfaces of the bent or end bent caps in accordance with the Standard Specifications, but do not use the Membrane Curing Compound method.

2.0 MATERIALS

Use an epoxy coating that meets the most recently published NCDOT Specification on the date of advertisement. Use the epoxy coating that meets NCDOT-Type 4A Flexible, epoxy coating, moisture insensitive.

Provide a certification for the proposed epoxy showing that it meets NCDOT-Type 4A.

The following companies have epoxies that meet Type 4A Specifications:

- E-Bond Epoxy, Inc.
Fort Lauderdale, Florida 33307
- Permagile Industries
Plainview, NY 11803
- Poly-Carb
Cleveland, OH 44139
- Tamms, Inc.
Mentor, OH 44060
- Adhesive Engineering
Cleveland, OH 44122-5554
- Kaufman Products
Baltimore, MD 21226-1131
- Prime Resins
Lithonia, GA 30058
- Sika Corporation
Lyndhurst, N. J. 07071

A copy of the specifications for Epoxy Resin Systems is available from the Materials and Tests Unit.

3.0 SURFACES

With the exception of cored slab bridges, apply the epoxy protective coating to the top surface area, including chamfer area, of bent caps under expansion joints and of end bent caps, excluding areas under elastomeric bearings. For cored slab bridges, do not apply the epoxy protective coating to the bent or end bent caps. Also, apply epoxy protective coating to the ends of prestressed concrete members as noted on the plans.

Use extreme care to keep the area under the elastomeric bearings free of the epoxy protective coating. Do not apply the epoxy protective coating in the notch at the ends of the prestressed concrete girders.

Thoroughly clean all dust, dirt, grease, oil, laitance, and other objectionable material from the concrete surfaces to be coated. Air-blast all surfaces immediately prior to applying the protective coating.

Only use cleaning agents pre-approved by the Engineer.

4.0 APPLICATION

Apply epoxy protective coating only when the air temperature is at least 40°F (4°C) and rising, but less than 95°F (35°C) and the surface temperature of the area to be coated is at least 40°F (4°C). Remove any excess or free standing water from the surfaces before applying the coating. Apply one coat of epoxy protective coating at a rate such that it covers between 100 and 200 ft²/gal (2.5 and 5 m²/liter).

Note: Under certain combinations of circumstances, the cured epoxy protective coating may develop “oily” condition on the surface due to amine blush. This condition is not detrimental to the applied system.

Apply the coating so that the entire designated surface of the concrete is covered and all pores filled. To provide a uniform appearance, use the exact same material on all visible surfaces.

5.0 BASIS OF PAYMENT

No separate measurement or payment will be made for preparing, furnishing and applying the epoxy protective coating to the concrete surfaces.

Payment at the contract unit prices for the various pay items will be full compensation for the above work including all materials, equipment, tools, labor, and incidentals necessary to complete the work.

FALSEWORK AND FORMWORK

(10-12-01)

1.0 DESCRIPTION

Use this Special Provision as a guide to develop temporary works submittals required by the Standard Specifications or other provisions; no additional submittals are required herein. Such temporary works include, but are not limited to, falsework and formwork.

Falsework is any temporary construction used to support the permanent structure until it becomes self-supporting. Formwork is the temporary structure or mold used to retain plastic or fluid concrete in its designated shape until it hardens. Access scaffolding is a temporary structure that functions as a work platform that supports construction personnel, materials, and tools, but is not intended to support the structure. Scaffolding systems that are used to temporarily support permanent structures (as opposed to functioning as work platforms) are considered to be falsework under the definitions given. Shoring is a component of falsework such as horizontal, vertical, or inclined support members. Where the term "temporary works" is used, it includes all of the temporary facilities used in bridge construction that do not become part of the permanent structure.

Design and construct safe and adequate temporary works that will support all loads imposed and provide the necessary rigidity to achieve the lines and grades shown on the plans in the final structure.

2.0 MATERIALS

Select materials suitable for temporary works; however, select materials that also ensure the safety and quality required by the design assumptions. The Engineer has authority to reject material on the basis of its condition, inappropriate use, safety, or nonconformance with the plans. Clearly identify allowable loads or stresses for all materials or manufactured devices on the plans. Revise the plan and notify the Engineer if any change to materials or material strengths is required.

3.0 DESIGN REQUIREMENTS**A. Working Drawings**

Provide working drawings for items as specified in the contract, or as required by the Engineer, with design calculations and supporting data in sufficient detail to permit a structural and safety review of the proposed design of the temporary work.

When concrete placement is involved, include data such as the drawings of proposed sequence, rate of placement, direction of placement, and location of all construction joints. Submit the number of copies as called for by the contract.

When required, have the drawings and calculations prepared under the guidance of, and sealed by, a North Carolina Registered Professional Engineer who is knowledgeable in temporary works design.

Design falsework and formwork requiring submittals in accordance with the 1995 AASHTO *Guide Design Specifications for Bridge Temporary Works* except as noted herein.

1. Wind Loads

Table 2.2 of Article 2.2.5.1 is modified to include wind velocities up to 110 mph (177 km/hr). In addition, Table 2.2A is included to provide the maximum wind speeds by county in North Carolina.

Table 2.2 - Wind Pressure Values

Height Zone feet (m) above ground	Pressure, lb/ft ² (kPa) for Indicated Wind Velocity, mph (km/hr)				
	70 (112.7)	80 (128.7)	90 (144.8)	100 (160.9)	110 (177.0)
0 to 30 (0 to 9.1)	15 (0.72)	20 (0.96)	25 (1.20)	30 (1.44)	35 (1.68)
30 to 50 (9.1 to 15.2)	20 (0.96)	25 (1.20)	30 (1.44)	35 (1.68)	40 (1.92)
50 to 100 (15.2 to 30.5)	25 (1.20)	30 (1.44)	35 (1.68)	40 (1.92)	45 (2.15)
over 100 (30.5)	30 (1.44)	35 (1.68)	40 (1.92)	45 (2.15)	50 (2.39)

2. Time of Removal

The following requirements replace those of Article 3.4.8.2.

Do not remove forms until the concrete has attained strengths required in Article 420-17 of the Standard Specifications and these Special Provisions.

Do not remove forms until the concrete has sufficient strength to prevent damage to the surface.

Table 2.2A - Steady State Maximum Wind Speeds by Counties in North Carolina

COUNTY	25 YR (mph) (km/hr)	COUNTY	25 YR (mph) (km/hr)	COUNTY	25 YR (mph) (km/hr)
Alamance	70 (112.7)	Franklin	70 (112.7)	Pamlico	100 (160.9)
Alexander	70 (112.7)	Gaston	70 (112.7)	Pasquotank	100 (160.9)
Alleghany	70 (112.7)	Gates	90 (144.8)	Pender	100 (160.9)
Anson	70 (112.7)	Graham	80 (128.7)	Perquimans	100 (160.9)
Ashe	70 (112.7)	Granville	70 (112.7)	Person	70 (112.7)
Avery	70 (112.7)	Greene	80 (128.7)	Pitt	90 (144.8)
Beaufort	100 (160.9)	Guilford	70 (112.7)	Polk	80 (128.7)
Bertie	90 (144.8)	Halifax	80 (128.7)	Randolph	70 (112.7)
Bladen	90 (144.8)	Harnett	70 (112.7)	Richmond	70 (112.7)
Brunswick	100 (160.9)	Haywood	80 (128.7)	Robeson	80 (128.7)
Buncombe	80 (128.7)	Henderson	80 (128.7)	Rockingham	70 (112.7)
Burke	70 (112.7)	Hertford	90 (144.8)	Rowan	70 (112.7)
Cabarrus	70 (112.7)	Hoke	70 (112.7)	Rutherford	70 (112.7)
Caldwell	70 (112.7)	Hyde	110 (177.0)	Sampson	90 (144.8)
Camden	100 (160.9)	Iredell	70 (112.7)	Scotland	70 (112.7)
Carteret	110 (177.0)	Jackson	80 (128.7)	Stanley	70 (112.7)
Caswell	70 (112.7)	Johnston	80 (128.7)	Stokes	70 (112.7)
Catawba	70 (112.7)	Jones	100 (160.9)	Surry	70 (112.7)
Cherokee	80 (128.7)	Lee	70 (112.7)	Swain	80 (128.7)
Chatham	70 (112.7)	Lenoir	90 (144.8)	Transylvania	80 (128.7)
Chowan	90 (144.8)	Lincoln	70 (112.7)	Tyrell	100 (160.9)
Clay	80 (128.7)	Macon	80 (128.7)	Union	70 (112.7)
Cleveland	70 (112.7)	Madison	80 (128.7)	Vance	70 (112.7)
Columbus	90 (144.8)	Martin	90 (144.8)	Wake	70 (112.7)
Craven	100 (160.9)	McDowell	70 (112.7)	Warren	70 (112.7)
Cumberland	80 (128.7)	Mecklenburg	70 (112.7)	Washington	100 (160.9)
Currituck	100 (160.9)	Mitchell	70 (112.7)	Watauga	70 (112.7)
Dare	110 (177.0)	Montgomery	70(112.7)	Wayne	80 (128.7)
Davidson	70 (112.7)	Moore	70 (112.7)	Wilkes	70 (112.7)
Davie	70 (112.7)	Nash	80 (128.7)	Wilson	80 (128.7)
Duplin	90 (144.8)	New Hanover	100 (160.9)	Yadkin	70 (112.7)
Durham	70 (112.7)	Northampton	80 (128.7)	Yancey	70 (112.7)
Edgecombe	80 (128.7)	Onslow	100 (160.9)		
Forsyth	70 (112.7)	Orange	70 (112.7)		

Note on the working drawings any anchorages, connectors, inserts, steel sleeves or other such devices used as part of the falsework or formwork that remains in the permanent structure. If the plan notes indicate that the structure contains the necessary corrosion protection required for a Corrosive Site, epoxy coat, galvanize, metallize or otherwise protect these devices as directed by the Engineer. Any coating required by the Engineer will be considered incidental to the various pay items requiring temporary works.

B. Review and Approval

The Engineer is responsible for the review and approval of temporary works' drawings.

Submit the working drawings sufficiently in advance of proposed use to allow for their review, revision (if needed), and approval without delay to the work.

Do not start construction of any temporary work for which working drawings are required until the drawings have been approved. Such approval does not relieve the Contractor of the responsibility for the accuracy and adequacy of the working drawings.

The time period for review of the working drawings does not begin until complete drawings and design calculations, when required, are received by the Engineer.

On the drawings, show all information necessary to allow the design of any component to be checked independently as determined by the Engineer.

If requested by the Engineer, submit with the working drawings manufacturer's catalog data listing the weight of all construction equipment that will be supported on the temporary work. Show anticipated total settlements and/or deflections of falsework and forms on the working drawings. Include falsework footing settlements, joint take-up, and deflection of beams or girders. Design the falsework and forms supporting deck slabs and overhangs on girder bridges so that there will be no differential settlement between the girders and the deck forms during placement of deck concrete.

4.0 CONSTRUCTION REQUIREMENTS

All requirements of Section 420 of the Standard Specifications apply.

Construct temporary works in conformance with the approved working drawings. Ensure that the quality of materials and workmanship employed is consistent with that assumed in the design of the temporary works. Do not weld falsework members to any portion of the permanent structure unless approved. Show any welding to the permanent structure on the approved construction drawings.

Provide tell-tales attached to the forms and extending to the ground, or other means, for accurate measurement of falsework settlement. Make sure that the anticipated compressive settlement and/or deflection of falsework does not exceed 1 inch (25 mm). For cast-in-place concrete structures, make sure that the calculated deflection of falsework

flexural members does not exceed $1/240$ of their span regardless of whether or not the deflection is compensated by camber strips.

A. Maintenance and Inspection

Inspect and maintain the temporary work in an acceptable condition throughout the period of its use. Certify that the manufactured devices have been maintained in a condition to allow them to safely carry their rated loads. Clearly mark each piece so that its capacity can be readily determined at the job site.

Perform an in-depth inspection of an applicable portion(s) of the temporary works, in the presence of the Engineer, not more than 24 hours prior to the beginning of each concrete placement. Inspect other temporary works at least once a month to ensure that they are functioning properly. Have a North Carolina Registered Professional Engineer inspect the cofferdams, shoring, sheathing, support of excavation structures, and support systems for load tests prior to loading.

B. Foundations

Determine the safe bearing capacity of the foundation material on which the supports for temporary works rest. If required by the Engineer, conduct load tests to verify proposed bearing capacity values that are marginal or in other high-risk situations.

The use of the foundation support values shown on the contract plans of the permanent structure is permitted if the foundations are on the same level and on the same soil as those of the permanent structure.

Allow for adequate site drainage or soil protection to prevent soil saturation and washout of the soil supporting the temporary works supports.

If piles are used, the estimation of capacities and later confirmation during construction using standard procedures based on the driving characteristics of the pile is permitted. If preferred, use load tests to confirm the estimated capacities; or, if required by the Engineer conduct load tests to verify bearing capacity values that are marginal or in other high risk situations.

The Engineer reviews and approves the proposed pile and soil bearing capacities.

5.0 REMOVAL

Unless otherwise permitted, remove and keep all temporary works upon completion of the work. Do not disturb or otherwise damage the finished work.

Remove temporary works in conformance with the contract documents. Remove them in such a manner as to permit the structure to uniformly and gradually take the stresses due to its own weight.

6.0 METHOD OF MEASUREMENT

Unless otherwise specified, temporary works will not be directly measured.

7.0 BASIS OF PAYMENT

Payment at the contract unit prices for the various pay items requiring temporary works will be full compensation for the above falsework and formwork.

SUBMITTAL OF WORKING DRAWINGS**(6-7-05)****1.0 GENERAL**

Submit working drawings in accordance with Article 105-2 of the Standard Specifications and the requirements of this Special Provision. The list of submittals contained herein does not represent a list of required submittals for this project. Submittals are only necessary for those items as required by the Standard Specifications, other Special Provisions, or contract plans. Make submittals that are not specifically noted in this Special Provision directly to the Resident Engineer.

If submittals contain variations from plan details or specifications, significantly affect project cost, or significantly affect field construction or operations, discuss them with, and submit them through, the Resident Engineer. State the reason for the proposed variation in the submittals. To minimize overall review time, make sure all working drawing submittals are complete when first submitted. Provide a contact name and phone number with each submittal. Direct any questions regarding working drawing submittal requirements to the Resident Engineer, Structure Design Unit contacts or the Geotechnical Engineering Unit contacts noted below.

2.0 WORKING DRAWINGS SUBMITTAL CONTACTS

All submittals noted herein are reviewed by the Structure Design Unit and/or the Geotechnical Engineering Unit.

For submittals to the Structure Design Unit, use the following addresses:

Via US mail:

Mr. G. R. Perfetti, P. E.
 State Bridge Design Engineer
 North Carolina Department
 of Transportation
 Structure Design Unit
 1581 Mail Service Center
 Raleigh, NC 27699-1581
 Attention: Mr. P. D. Lambert, P. E.

Via other delivery service:

Mr. G. R. Perfetti, P. E.
 State Bridge Design Engineer
 North Carolina Department
 of Transportation
 Structure Design Unit
 1000 Birch Ridge Drive
 Raleigh, NC 27610
 Attention: Mr. P. D. Lambert, P. E.

For submittals to the Geotechnical Engineering Unit, use the following addresses:

For projects in Divisions 1-7, use the following Eastern Regional Office address:

Via US mail:

Mr. K. J. Kim, Ph. D., P. E.
Eastern Regional Geotechnical
Manager
North Carolina Department
of Transportation
Geotechnical Engineering Unit
Eastern Regional Office
1570 Mail Service Center
Raleigh, NC 27699-1570

Via other delivery service:

Mr. K. J. Kim, Ph. D., P. E.
Eastern Regional Geotechnical
Manager
North Carolina Department
of Transportation
Geotechnical Engineering Unit
Eastern Regional Office
3301 Jones Sausage Road, Suite 100
Garner, NC 27529

For projects in Divisions 8-14, use the following Western Regional Office address:

Via US mail:

Mr. John Pilipchuk, L. G., P. E.
Western Regional Geotechnical
Manager
North Carolina Department
of Transportation
Geotechnical Engineering Unit
Western Regional Office
5253 Z Max Boulevard
Harrisburg, NC 28075

Via other delivery service:

Mr. John Pilipchuk, L. G., P. E.
Western Region Geotechnical
Manager
North Carolina Department
of Transportation
Geotechnical Engineering Unit
Western Regional Office
5253 Z Max Boulevard
Harrisburg, NC 28075

Direct any questions concerning submittal review status, review comments, or drawing markups to the following contacts:

Primary Structures Contact:

Paul Lambert
(919) 250 – 4041
(919) 250 – 4082 facsimile
plambert@dot.state.nc.us

Secondary Structures Contacts:

James Gaither (919) 250 – 4042
Man-Pan Hui (919) 250 – 4044

Eastern Regional Geotechnical Contact (Divisions 1-7):

K. J. Kim
(919) 662 – 4710
(919) 662 – 3095 facsimile
kkim@dot.state.nc.us

Western Regional Geotechnical Contact (Divisions 8-14):

John Pilipchuk
(704) 455 – 8902
(704) 455 – 8912 facsimile
jpilipchuk@dot.state.nc.us

3.0 SUBMITTAL COPIES

The quantities provided in this Special Provision act as a guide in the submittal process.

Unless otherwise required by the contract, submit two sets of supporting calculations to the Structure Design Unit.

Furnish one complete copy of the submittal, including all attachments, to the Resident Engineer. If requested, provide additional copies of any submittal. At the same time, submit the following number of copies directly to the Structure Design Unit and/or the Geotechnical Engineering Unit:

Working Drawing Submittal	Copies Required by Structure Design Unit	Copies Required by Geotechnical Engineering Unit	Contract Reference Requiring Submittal¹
Arch Culvert Falsework	5	0	Plan Note & SN Sheet
Box Culvert Falsework ²	5	0	Plan Note & SN Sheet
Cofferdams ⁴	6	1	Articles 410-5 and 420-8
Expansion Joint Seals (hold down plate type with base angle)	9	0	“Expansion Joint Seals”
Expansion Joint Seals (modular)	2, then 9	0	“Modular Expansion Joint Seals”
Expansion Joint Seals (strip seals)	9	0	“Strip Seals”
Falsework & Forms (superstructure)	8	0	Article 420-3
Falsework & Forms ² (substructure)	8	0	Article 420-3
Mechanically Stabilized Earth Retaining Walls ⁴	7	1	“MSE Retaining Walls”
Metal Bridge Railing	8	0	Plan Note
Metal Stay-in-Place Forms	8	0	Article 420-3
Metalwork for Elastomeric Bearings ^{5,6}	7	0	Article 1072-10
Miscellaneous Metalwork ^{5,6}	7	0	Article 1072-10
Overhead Sign Assemblies	13	0	Article 903-3(C)
Pile Points	7	1	Article 450-8(D) & “Steel Pile Points”
Placement of Equipment on Structures (cranes, etc.)	7	0	Article 420-20

Precast Concrete Box Culverts	2, then 1 reproducible	0	“(Optional) Precast Reinforced Concrete Box Culvert at Station ____”
Precast Retaining Wall Panels	10	0	Article 1077-2
Pot bearings ⁵	8	0	“Pot Bearings”
Prestressed Concrete Deck Panels	6 and 1 reproducible	0	Article 420-3
Proprietary retaining walls ⁴	9	0	Applicable Project Special Provision
Prestressed Concrete Girder (strand elongation and detensioning sequences)	6	0	Articles 1078-8 and 1078-11
Prestressed Concrete Cored Slab (detensioning sequences) ³	6	0	Article 1078-11
Revised Bridge Deck Plans (adaptation to metal stay-in-place forms)	2, then 1 reproducible	0	Article 420-3
Revised Bridge Deck Plans (adaptation to modular expansion joint seals)	2, then 1 reproducible	0	“Modular Expansion Joint Seals”
Soil Nail Retaining Walls ⁴	4	1	Applicable Project Special Provision
Sound Barrier Wall Steel Fabrication Plans ⁶	7	0	Article 1072-10 & “Sound Barrier Wall”
Sound Barrier Wall Casting Plans	10	0	Article 1077-2 & “Sound Barrier Wall”
Structural Steel ⁵	2, then 7	0	Article 1072-10
TFE Expansion Bearings ⁵	8	0	Article 1072-10
Temporary Detour Structures ⁴	10	1	Article 400-3 & “Construction, Maintenance and Removal of Temporary Structure at Station ____”
Temporary Shoring ⁴	6	1	Article 410-4 & “Temporary Shoring for Maintenance of Traffic”

Temporary Fabric or Wire Walls ⁸	0	2	Applicable Project Special Provision
Permanent Anchored Tieback Retaining Walls ⁴	4	1	Applicable Project Special Provision
Evazote Joint Seals ⁷	9	0	Applicable Project Special Provision
Optional Disc Bearings ⁵	8	0	“Optional Disc Bearings”
Removal of Existing Structure over Railroad	5	0	Railroad Special Provisions
Drilled Pier Construction Sequence Plans ⁸	0	1	“Drilled Piers”
Pile Hammers ⁸	0	1	Article 450-6
Crosshole Sonic Logging (CSL) Reports ⁸	0	1	“Crosshole Sonic Logging”
Pile Driving Analyzer (PDA) Reports ⁸	0	1	“Pile Driving Analyzer”

FOOTNOTES

1. References are provided to help locate the part of the contract where the working drawing submittals are required. References in quotes refer to the Project Special Provision by that name. Articles refer to the Standard Specifications.
2. Submittals for these items are necessary only when plan notes require them.
3. Submittals for these items may not be required. A list of pre-approved sequences is available from the producer or the Materials and Tests Unit.
4. These submittals are reviewed by the Structure Design Unit and the Geotechnical Engineering Unit. If NCDOT Shoring Standards are used, working drawings need not be submitted, but the Shoring Selection Form should be forwarded to the Geotechnical Engineering Unit.
5. The fabricator may submit these items directly to the Structure Design Unit.
6. The two sets of preliminary submittals required by Article 1072-10 of the Standard Specifications are not required for these items.
7. Submittals for Fabrication Drawings are not required. Submission of Catalogue Cuts of Proposed Material is required. See Section 5.A of the Project Special Provision.
8. Submittals for these items are reviewed by the Geotechnical Engineering Unit only and correspondence regarding these items should be directed to and will come from the Geotechnical Engineering Unit.

**CONSTRUCTION, MAINTENANCE AND REMOVAL
OF TEMPORARY ACCESS AT STATION 17+03.50 -L-**

(2-14-04)

1.0 GENERAL

Construct, maintain, and remove the temporary access required to provide the working area necessary to construct the bridge and, if applicable, remove an existing bridge. Temporary access may include other methods than those outlined in this Special Provision; however, all types of temporary access are required to meet the requirements of all permits, the Standard Specifications, and this Special Provision.

2.0 TEMPORARY ROCK CAUSEWAY [WORKPAD]

If detailed on the plans, construction of a temporary rock causeway [workpad] within the limits shown on the plans is permitted. Build the causeway [workpad] with Class II riprap topped by a layer of Class A riprap or as otherwise designated on the plans or approved by the Engineer. If desired, recycle the Class II riprap used in the causeway [workpad] for placement in the final riprap slope protection as directed by the Engineer. No payment will be made for recycled riprap as this material is considered incidental to the causeway [workpad] placement and removal. If this option is exercised, no adjustment in contract bid price will be allowed due to an underrun in the quantity of "Plain Rip Rap Class II (2'-0" (600 mm) Thick)".

Completely remove all causeway [workpad] material including pipes and return the entire causeway [workpad] footprint to the original contours and elevations within 90 days of the completion of the deck slab or as otherwise required by permits.

For sites affected by moratoriums of restrictions on in-stream work: Do not construct or remove causeway [workpad] during the moratorium period shown on the permit. If the completion of the deck slab falls within the prohibitive dates for causeway [workpad] construction or removal, begin causeway [workpad] removal immediately following the prohibitive dates.

3.0 TEMPORARY WORK BRIDGE

If noted on the plans, the construction of a temporary work bridge is permitted. Submit details of the temporary work bridge to the Engineer prior to constructing the work bridge to ensure conformance with the plans and all permits. Make certain that the temporary work bridge satisfies all permits. Completely remove the temporary bridge prior to final acceptance or as otherwise required by the permits.

If a causeway [workpad] is detailed on the plans, the construction of a temporary work bridge in lieu of the causeway [workpad] is permitted. If this option is exercised, prepare all necessary documents required for permit modifications, if any.

4.0 BASIS OF PAYMENT

The lump sum price bid for “Construction, Maintenance and Removal of Temporary Access at Station _____” will be full compensation for the above work, or other methods of access, including all material, pipes, work bridge components, equipment, tools, labor, disposal, and incidentals necessary to complete the work.

ELASTOMERIC BEARINGS

(10-03-02)

Use elastomeric bearings in accordance with Article 1079-2 of the Standard Specifications except as follows:

**TABLE 1079-2
NATURAL RUBBER ELASTOMER REQUIREMENTS**

Grade (durometer)	50	60
PHYSICAL PROPERTIES Hardness ASTM D2240	50 +5 -5	60 +5 -5

UNCLASSIFIED STRUCTURE EXCAVATION AT STATION 17+03.50 -L-

(12-12-02)

The 2002 Standard Specifications shall be revised as follows:

Unclassified structure excavation shall be in accordance with Section 412 of the Standard Specifications with the following exception:

Payment will be made under:

Unclassified Structure Excavation at Station _____.....Lump Sum

PRESTRESSED CONCRETE MEMBERS

3-04-05

In Section 1078-12 of the Standard Specifications. After the first sentence of “5,” place the following:

“Conduit may be rigid one-piece or rigid two-piece (split sheathed). Do not use flexible conduit.”

In Section 1078-13 of the Standard Specifications, after the fourth paragraph add the following paragraph:

“When handling the prestressed concrete members, a temporary stress of $5\sqrt{f_{ci}}$ is permitted, where f_{ci} is the strength of concrete at release, in psi.”

In Section 1078-5 of the Standard Specifications, place the following two sentences after the first paragraph:

“When casting holes through the top flange of Bulb Tee Girders for overhang or interior bay falsework hanger rods use rigid PVC conduits with a wall thickness of approximately 1/8 inch. Do not use thin wall material. Secure conduits in the forms so that they do not migrate out of the proper location. Other methods of forming holes may be proposed but are subject to the Engineer’s approval.”

“When casting dowel rod holes in cored slab or box beam members use material that creates round, vertical holes of the specified diameter and in the correct location. Do not use material that deforms, collapses or shifts position during casting of the member.”

CRANE SAFETY

08-15-05

Comply with the manufacturer specifications and limitations applicable to the operation of any and all cranes and derricks. Prime contractors, sub-contractors, and fully operated rental companies shall comply with the current Occupational Safety and Health Administration regulations (OSHA).

Submit all items listed below to the Engineer prior to beginning crane operations involving critical lifts. A critical lift is defined as any lift that exceeds 75 percent of the manufacturer’s crane chart capacity for the radius at which the load will be lifted or requires the use of more than one crane. Changes in personnel or equipment must be reported to the Engineer and all applicable items listed below must be updated and submitted prior to continuing with crane operations.

CRANE SAFETY SUBMITTAL LIST

- A. **Competent Person:** Provide the name and qualifications of the “Competent Person” responsible for crane safety and lifting operations. The named competent person will have the responsibility and authority to stop any work activity due to safety concerns.
- B. **Riggers:** Provide the qualifications and experience of the persons responsible for rigging operations. Qualifications and experience should include, but not be limited to, weight calculations, center of gravity determinations, selection and inspection of sling and rigging equipment, and safe rigging practices.

- C. **Crane Inspections:** Inspection records for all cranes shall be current and readily accessible for review upon request.
- D. **Certifications:** By July 1, 2006, crane operators performing critical lifts shall be certified by NC CCO (National Commission for the Certification of Crane Operators), or satisfactorily complete the Carolinas AGC's Professional Crane Operator's Proficiency Program. Other approved nationally accredited programs will be considered upon request. All crane operators shall also have a current CDL medical card. Submit a list of anticipated critical lifts and corresponding crane operator(s). Include current certification for the type of crane operated (small hydraulic, large hydraulic, small lattice, large lattice) and medical evaluations for each operator.

PRESTRESSED CONCRETE BOX BEAM

03-04-05

The prestressed box beam members shall meet the requirements for prestressed concrete members as specified in the Standard Specifications with the following exceptions and additions.

1.0 FABRICATION

Place concrete for box beams in 2 or more horizontal layers. Place and compact each layer before the preceding layer takes initial set so that there is no surface or separation between layers. Should shrinkage or settlement cracks occur, the Engineer reserves the right to require additional layers and/or vibration.

The requirements of the above paragraph may be waived if use of self-consolidating concrete is approved by the Engineer.

When box beams are cast, a positive hold-down system shall be employed to prevent voids from moving. Design the system to be left in place until the concrete has reached the release strength. At least six weeks prior to casting box beams, the Contractor shall submit to the Engineer for review and comment, detailed drawings of the proposed void material and hold-down system. In addition to structural details, location and spacing of the hold-downs shall be indicated. The Contractor shall also submit his proposed method of concrete placement and of consolidating the concrete under the void.

Rake the top surface of the box beam section to a depth of 3/8" (10 mm). No surface finish is required for sides and bottom of the box beam sections except the exposed side of the exterior beam section as noted below. Provide a resulting surface finish essentially the same color and surface finish as the surrounding concrete. Fill all voids in the outside face of exterior box beams with a sand-cement or other approved grout. Repair voids greater than 1/4" (6 mm) in diameter or depth in other faces of the box beams in a like manner. Where an excessive number of smaller voids exist in any member, the Engineer requires a similar repair.

Provide a 3/4" (19 mm) chamfer along the bottom edges on ends and sides of all beam sections, top outside edges of exterior beam sections and acute corners of beam sections. Round the top edges on ends of all sections with a 1/4" (6 mm) finishing tool. Provide square corners along top edges on all slab sections along shear keys. Do not chamfer vertical edges at ends of beam sections.

2.0 ALIGNMENT AND DIRECTIONAL TOLERANCES

In order to ensure a good, neat field fit, assemble box beam spans in the yard and have pieces match-marked. Ensure that pieces fit together neatly and in a workman-like manner. Manufacture the box beams within the tolerances listed in the "Box Beam Tolerances" table and sketches.

3.0 ERECTION

The post tensioning system shall use 0.6" (15mm) diameter strands or 1¼" (32mm) diameter steel bars. Steel bars shall have a minimum yield strength of 150,000 psi (1034.2 MPa), meeting the requirements of ASTM A722. Strands shall be tensioned to 43,950 pounds (195.5 kN) and bars shall be tensioned to 150,000 pounds (667 kN). Strands shall be placed in a non-corrosive 0.6" (15mm) diameter, 1/16" (1.6mm) minimum wall thickness black polyethylene pipe meeting the requirements of ASTM D2239. Similarly, bars shall be placed in a black polyethylene pipe.

When erecting prestressed box beams, place the transverse post tensioning system in the diaphragms, place grout in the grout pockets located at the areas of the post tensioning strands, if provided, and tension to the required force. Grease the bars or strands and place in the polyethylene pipe. Do not apply grease or extend the pipe in the area of the recesses at the ends of the tensioning strands where grout is applied. Tension the bars or strands in the diaphragm nearest mid-span first. Proceed to tension bars or strands in the adjacent diaphragms. Continue the tensioning operation in a symmetric manner along the length of the span. At each diaphragm location, maintain a symmetric tension force between each pair of bars or strands in the diaphragm. After all tensioning in a span is completed and before placing any equipment, material or barrier rail on the span, fill the shear key, dowel holes, and recesses at the ends of the diaphragm with an approved non-metallic, non-shrink grout. Cure for 3 days minimum and until the grout reaches a compressive strength of 3000 psi (20.7 MPa).

After tensioning and curing, obtain approval prior to placing material and equipment on the box beam spans. Support cranes or other equipment exceeding the legal load limit on mats. Submit for review a detailed drawing for the mats that are intended for use on the box beams. Provide a complete description of the equipment that is intended for placement on the mats. Supply and construct mats at no additional cost to the Department.

4.0 PAYMENT

The quantity of prestressed concrete box beams shown on the plans will be paid for at the contract unit price per linear foot for "_____ x _____ Prestressed Concrete Box Beams." This price and payment shall be full compensation for furnishing and placing the prestressed concrete box beams and includes all materials, tools, equipment, labor and incidentals necessary to complete this work.

BOX BEAM TOLERANCES:

- a = Length: ± 1 in.
- b = Width (overall): $\pm \frac{1}{4}$ in.
- c = Depth (overall): $\pm \frac{1}{4}$ in.
- d = Variation from specified plan end squareness or skew:
 $\pm \frac{1}{8}$ in. per 12 in. width, $\pm \frac{1}{2}$ in. max.
- e = Variation from specified elevation end squareness or skew:
 $\pm \frac{1}{8}$ in. per 12 in., $\pm \frac{1}{2}$ in. max.
- f = Sweep, for member length:
- | | |
|---------------------|-----------------------|
| up to 40 ft. | $\pm \frac{1}{4}$ in. |
| 40 to 60 ft. | $\pm \frac{3}{8}$ in. |
| greater than 60 ft. | $\pm \frac{1}{2}$ in. |
- g = Differential camber between adjacent members:
 $\frac{1}{4}$ in. per 10 ft., $\frac{3}{4}$ in. max.
- h = Local smoothness of any surface: $\frac{1}{4}$ in. in 10 ft.
- k = Position of strands: $\pm \frac{1}{4}$ in.
- n = Longitudinal Position of blockout: ± 1 in.
- o₁ = Position of dowel holes: $\pm \frac{1}{4}$ "
- o₂ = Position of sleeves cast in beams, in both horizontal and vertical plane: $\pm \frac{1}{2}$ in.
- p = Position of void: $\pm \frac{3}{8}$ "
- Bearing area – deviation from plane surface: $\pm \frac{1}{16}$ "
- Width of any one span = Plan width + $\frac{1}{8}$ " per joint

Box Beam Tolerances:

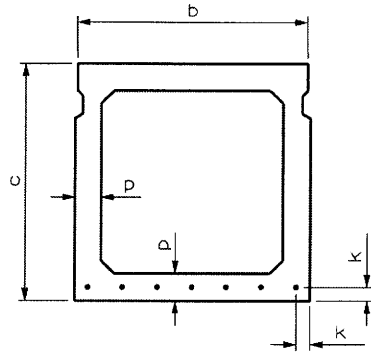

CROSS SECTION

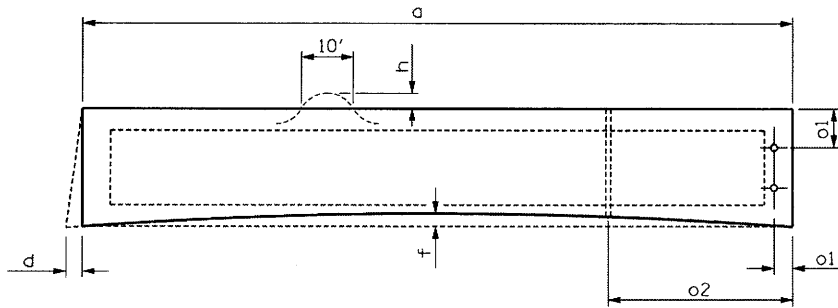

PLAN

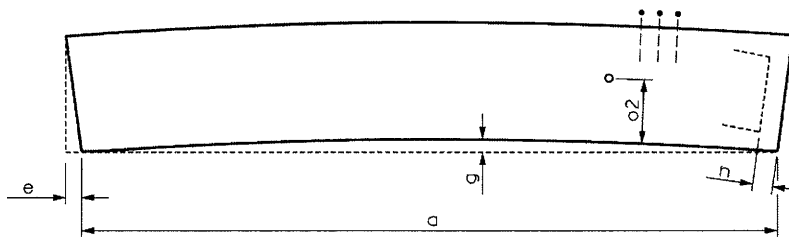

ELEVATION

STEEL H PILES

8-15-05

In Section 1084-3 “Steel Bearing Piles” of the Standard Specifications, revise the first sentence as follows:

Steel bearing piles must meet the requirements of ASTM A572 or ASTM A588 and have a grade of 50 [345].

**PROJECT SPECIAL PROVISIONS
POLYUREA PAVEMENT MARKING MATERIAL WITH
STANDARD GLASS BEADS**

Section 1205-1 DESCRIPTION:

This special provision covers machine applied Polyurea pavement marking material with both incorporated glass beads and drop-on glass beads. All remaining Articles in Section 1205 shall be as described in the 2002 Standard Specification for Roads and Structures with the exceptions below.

Section 1205-2 Materials

(A) General

Replace Article (A) with the following:

Section 1087-Articles 1, 3, 5 & 6 (General, Color, Packaging for Shipment, and Storage Life) shall be as described in the 2002 Standard Specifications for Roads and Structures. The manufacturer may recommend any remaining information necessary for the placement of Polyurea pavement markings.

(B) Material Qualification

Replace Article (B) with the following:

Use only Polyurea pavement markings that have been pre-approved by the Traffic Control Section prior to application. Use both incorporated glass beads and drop-on glass beads according to the manufacturer's recommendations in order to meet the retroreflectivity requirements as stated in Section 1205-3(G)(8) as measured by a LTL 2000, LTL-X or Department approved 30m mobile retroreflectometer.

Furnish a Type 3 Material Certification and Type 4 Material Certification in accordance with Article 106-3 as described in the 2002 Standard Specifications for Roads and Structures.

For more information, contact the Traffic Control Section at 919 250-4159.

Section 1205-3 Construction Methods

Section 1205-3(B) (1) General for all Application Equipment: Add the following sentence after the last paragraph:

Do not use handliners or any other non-truck mounted pavement marking machine to install Polyurea pavement markings on long-line applications.

Add the following Section immediately following Section 1205-3(G)(8)

Section 1205-3 (G) (9) Polyurea Application:

Produce Polyurea pavement marking lines that have a minimum dry thickness of 20 mils (0.50mm) when placed on concrete and asphalt pavements.

Using the Polyurea application equipment, apply the pavement materials simultaneously. Apply the Polyurea resin, mixed at the proper ratio according to the manufacturer's recommendations, to the pavement surfaces within the proper application temperatures as determined by the material manufacturer. Inject reflective glass beads into the molten (liquid) Polyurea pavement markings.

Apply glass beads according to manufacturer's recommendations. At the time of installation, provide in-place marking with the minimum reflectance values shown below, as obtained with a LTL 2000, LTL-X or Department approved 30m mobile retroreflectometer. Maintain the retroreflectance values shown below for a minimum of 30 days from the time of placement of marking material.

WHITE: 375 mcd/lux/m²

YELLOW: 250 mcd/lux/m²

Produce marking, which upon cooling, is uniformly reflectorized and has the ability to resist deformation caused by traffic throughout its entire length.

The manufacturer of the Polyurea pavement marking material shall certify the Contractor to place the material. Provide at least one member of each crew that completed this training. Furnish the Engineer written confirmation of the training from the material manufacturer prior to the beginning of work. The manufacturer's technical representative shall be onsite during the entire installation of product.

Provide a manufacturer's technical representative that is knowledgeable and familiar with the Contractors application equipment prior to the installation of the Polyurea pavement markings.

Section 1205-3(H)(1) Observation Period for Polyurea Pavement Markings:

Replace the first paragraph with the following:

Thermoplastic, epoxy, and polyurea pavement markings are subject to a 180 day observation period.

Add the following just before the last paragraph:

Provide polyurea pavement marking materials that maintain minimum retroreflectance values throughout the 180 day observation period as follows:

WHITE: 325 mcd/lux/m²
YELLOW: 200 mcd/lux/m²

These measurements will be taken by the Department within 30 days prior to the end of the Observation Period. The reflectance values shall be taken with an LTL 2000, LTL-X or Department approved 30m mobile retroreflectometer.

Section 1205-3(I) Removal of Pavement Markings:

Add the following just before the last paragraph:

Do not apply Polyurea pavement marking over existing pavement marking materials having less adherence than Polyurea. Remove existing lines according to the manufacturer's recommendations.

Measurement and Payment:

Measurement and payment shall be in accordance with Section 1205 of the North Carolina Standard Specifications for Roads and Structures.