

HALF SECTION @ INTERMEDIATE DIAPHRAGMS HALF SECTION @ 1'-0" Ø VOIDS

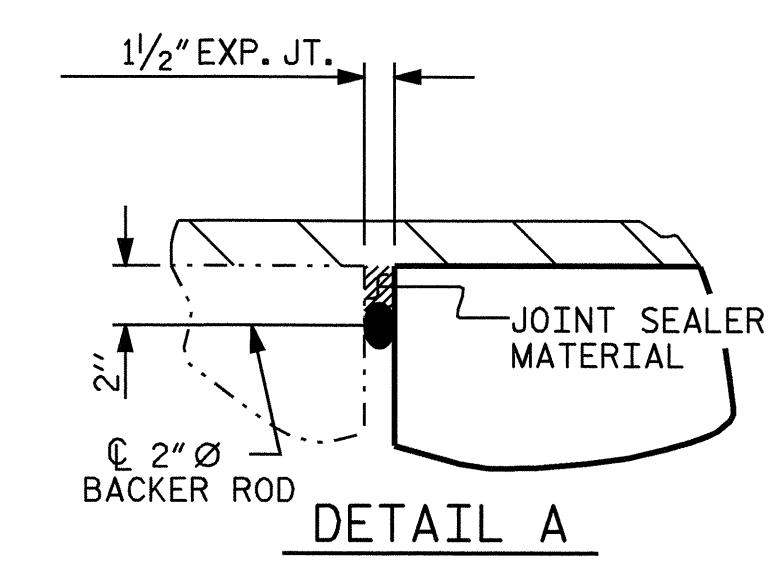

DETAIL A

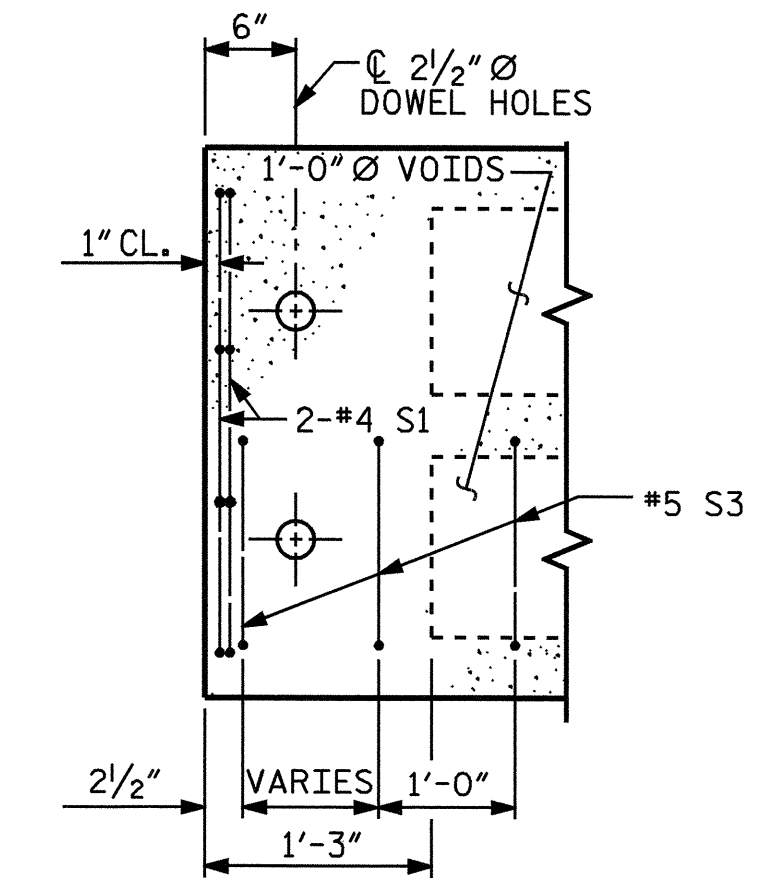

PART PLAN-EXTERIOR SECTION
NOTE: EXTERIOR SECTION SHOWN-INTERIOR SECTION SIMILAR EXCEPT OMIT S3 BARS. SEE PLAN OF SPAN

TYPICAL SECTION

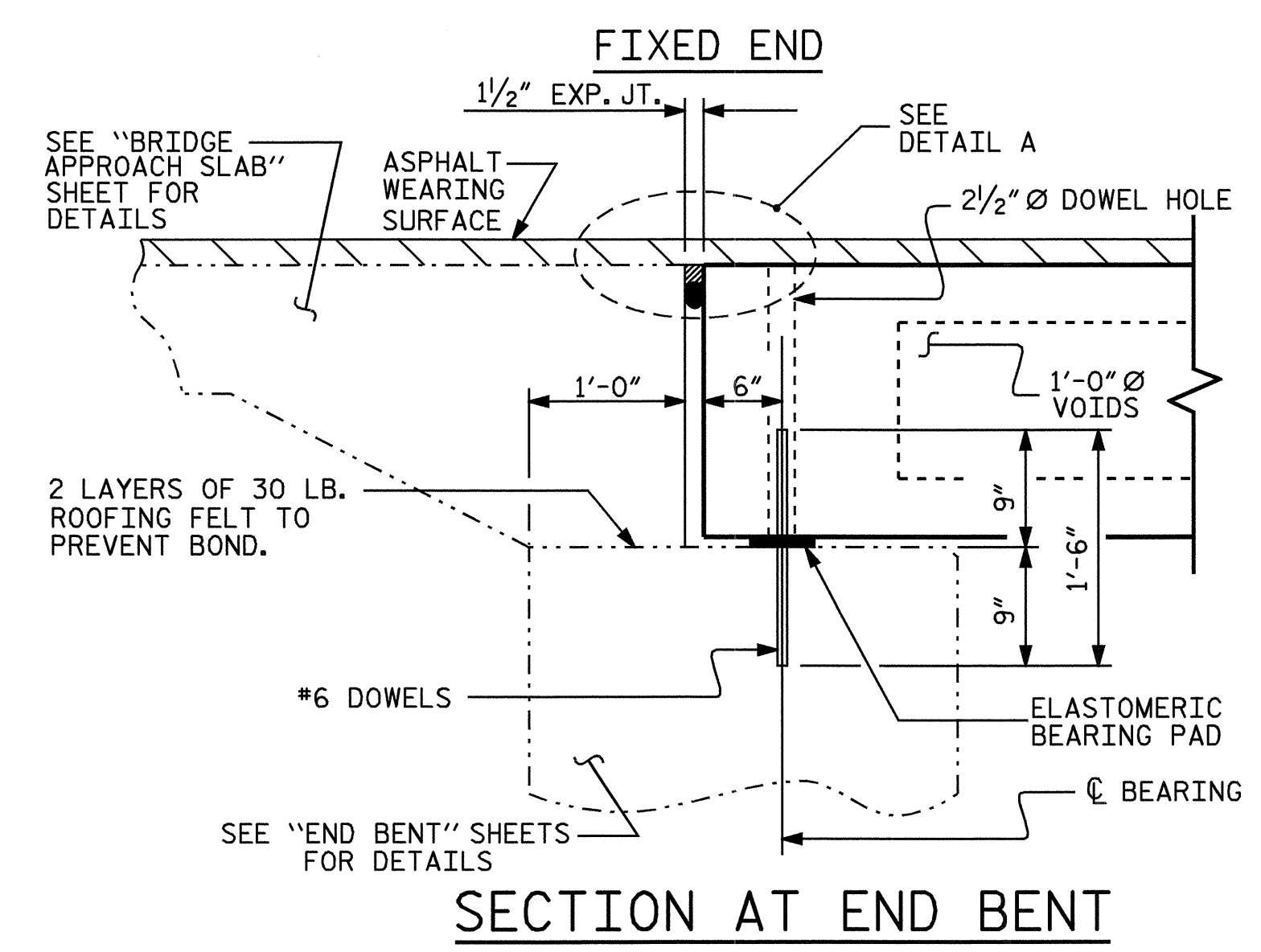

SECTION AT END BENT

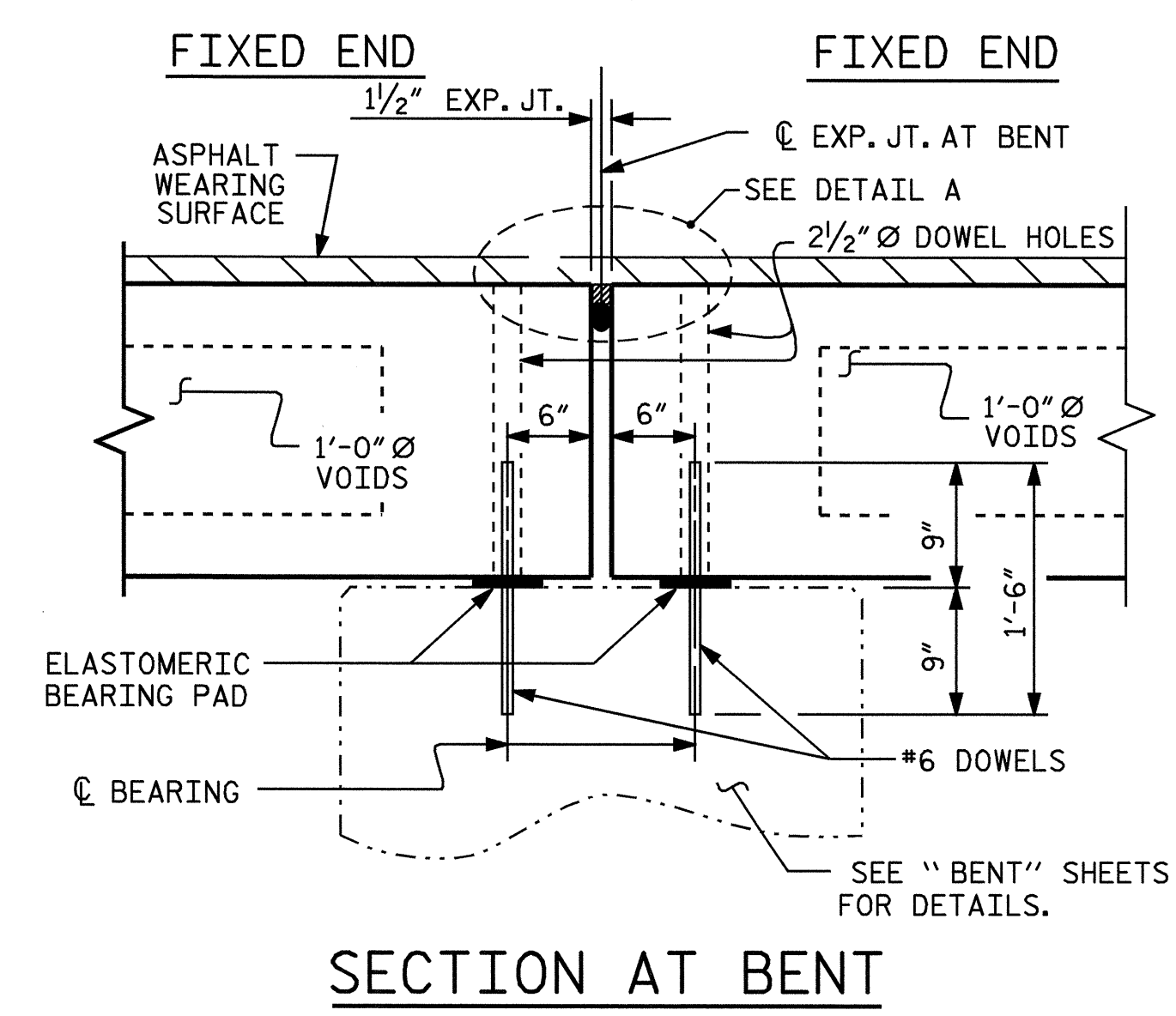

SECTION AT BENT

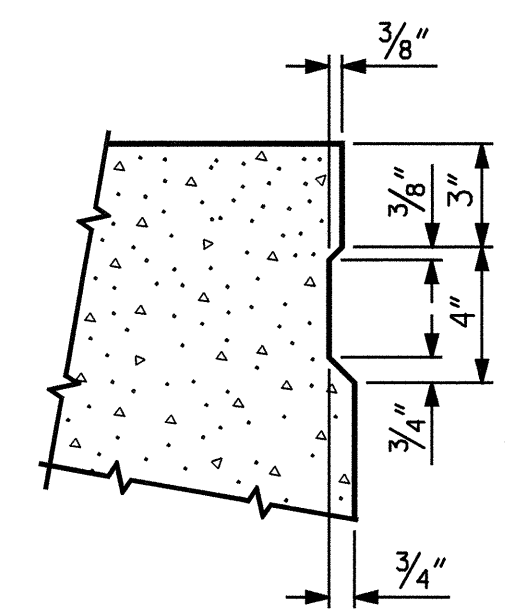

SHEAR KEY DETAIL
NOTE: OMIT SHEAR KEY ON OUTSIDE FACE OF EXTERIOR CORED SLABS.

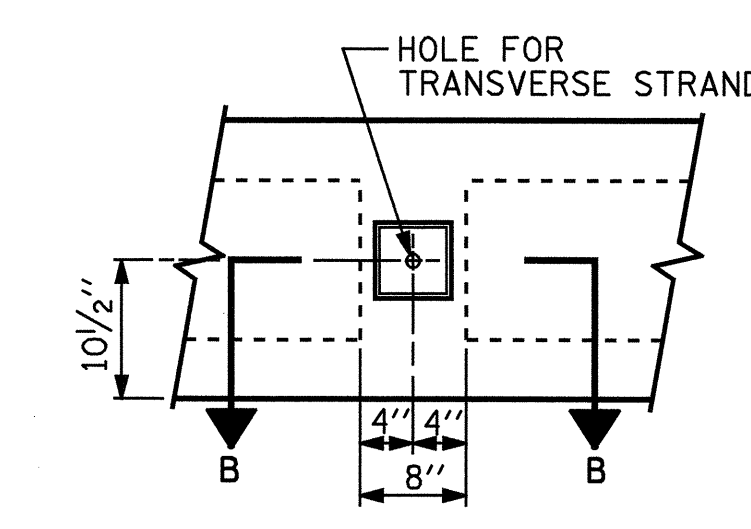

ELEVATION VIEW

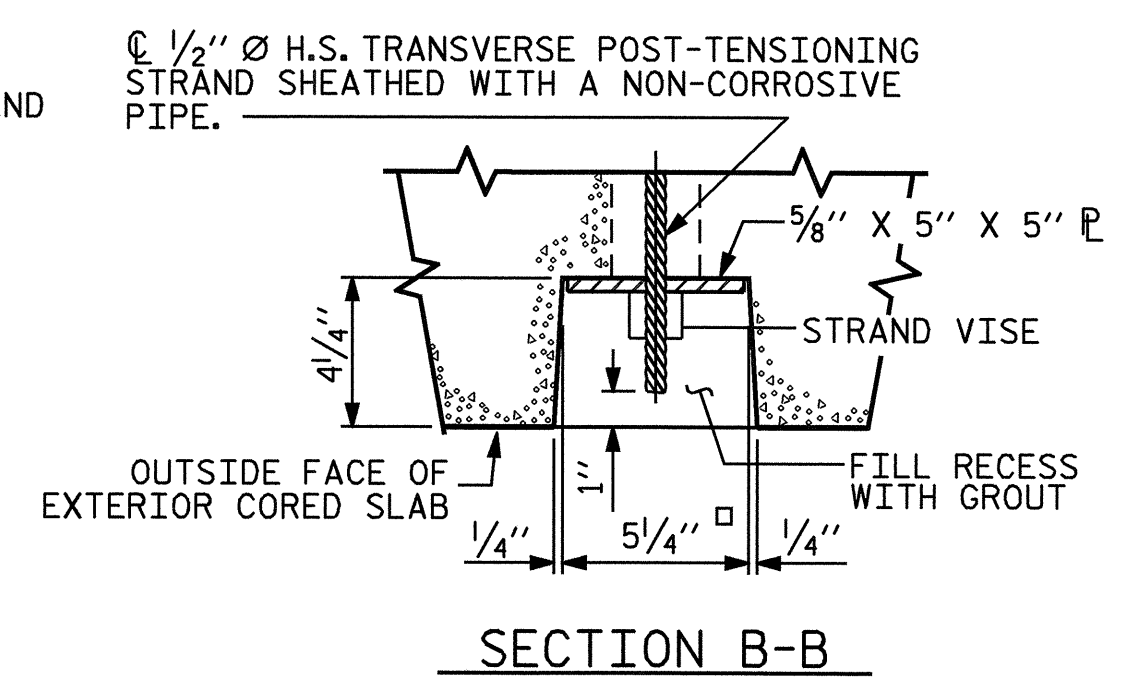

SECTION B-B

GROUTED RECESS AT END OF POST-TENSIONED STRAND CORED SLABS

◆ BOND SHALL BE BROKEN ON THESE STRANDS FOR A DISTANCE OF 4'-0" FROM END OF CORED SLAB UNIT, SEE STANDARD SPECIFICATIONS ARTICLE 1078-7.

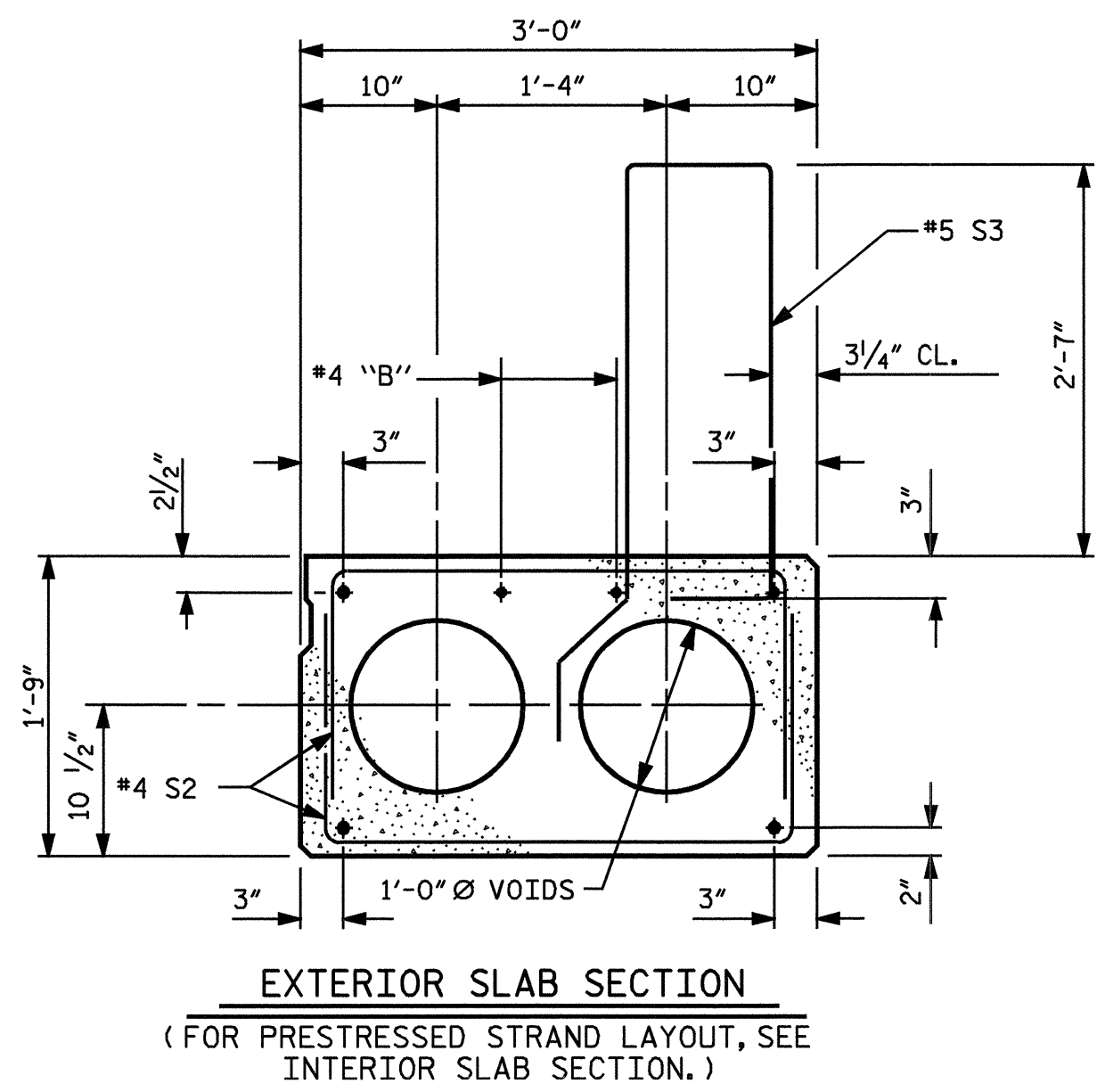

EXTERIOR SLAB SECTION

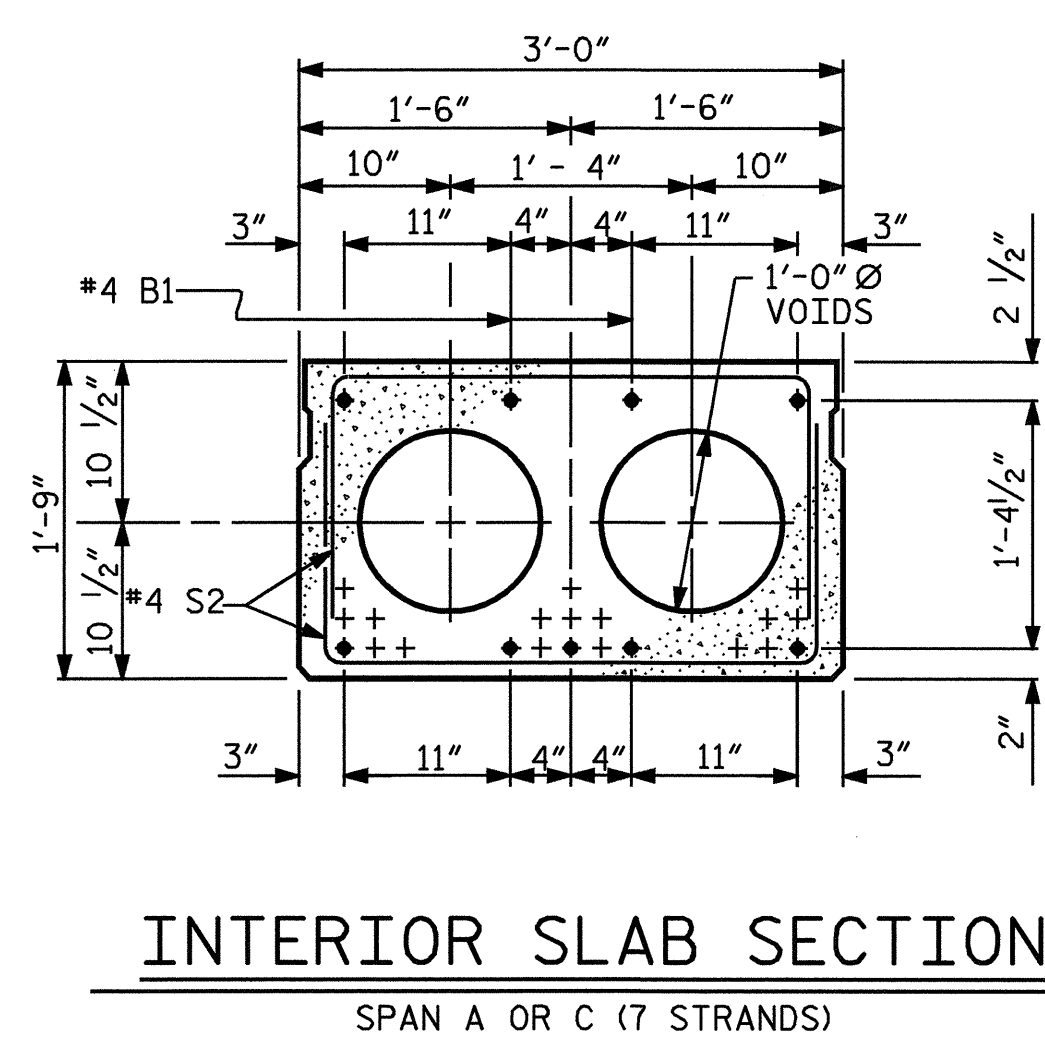

INTERIOR SLAB SECTION

SPAN A OR C (7 STRANDS)

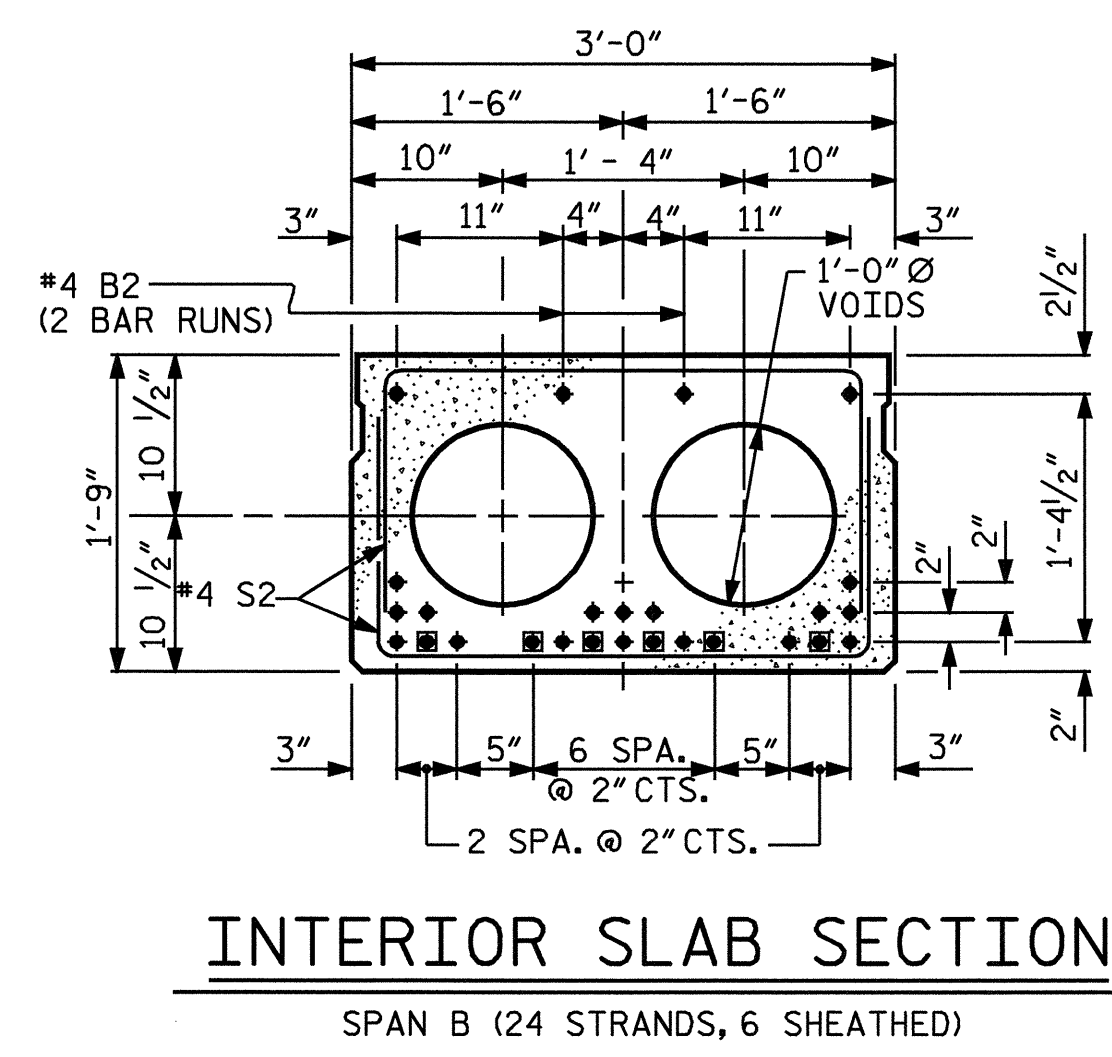

INTERIOR SLAB SECTION

SPAN B (24 STRANDS, 6 SHEATHED)

1/2" Ø LOW RELAXATION STRAND LAYOUT

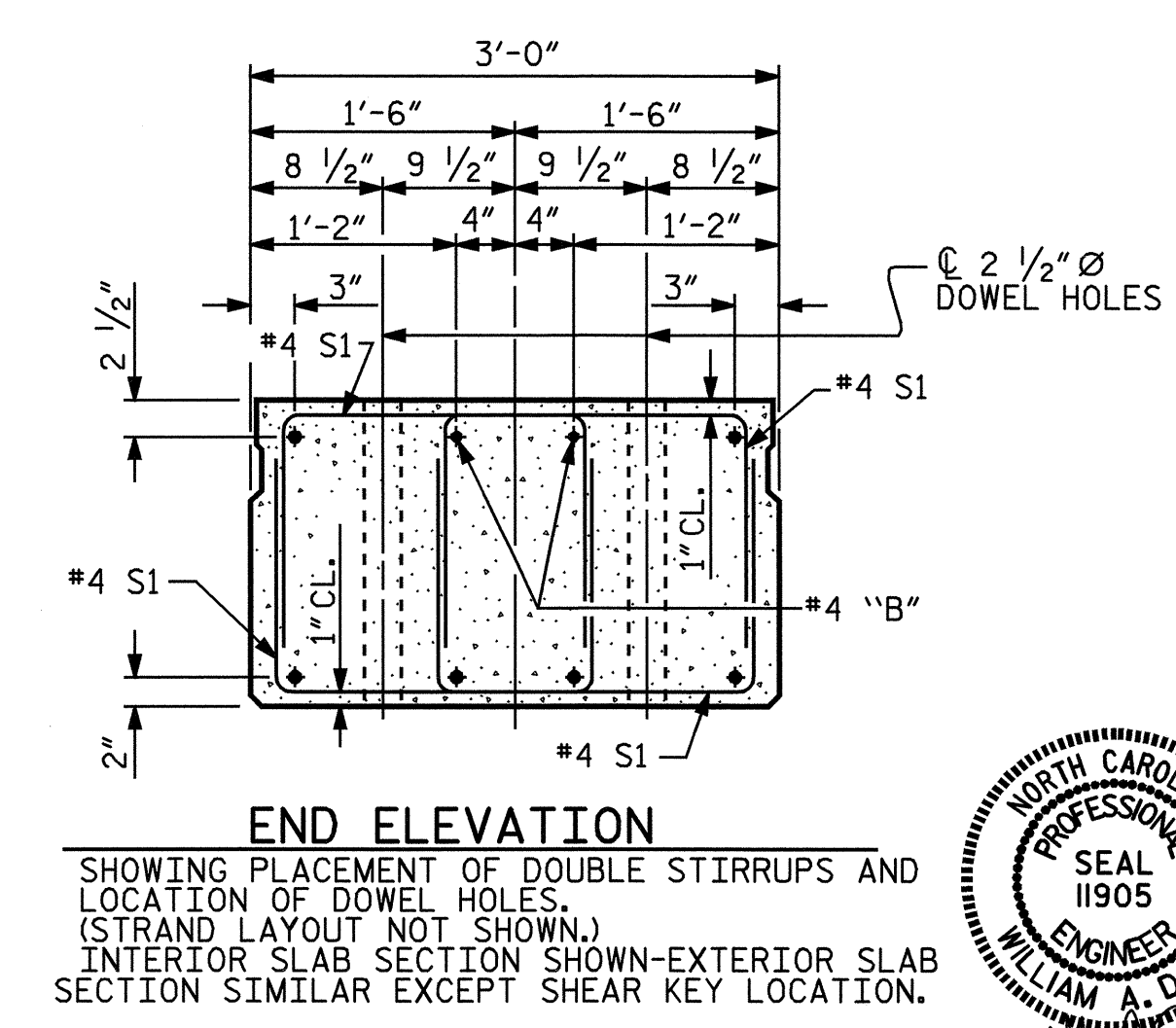

END ELEVATION

SHOWING PLACEMENT OF DOUBLE STIRRUPS AND LOCATION OF DOWEL HOLES. (STRAND LAYOUT NOT SHOWN.) INTERIOR SLAB SECTION SHOWN-EXTERIOR SLAB SECTION SIMILAR EXCEPT SHEAR KEY LOCATION.

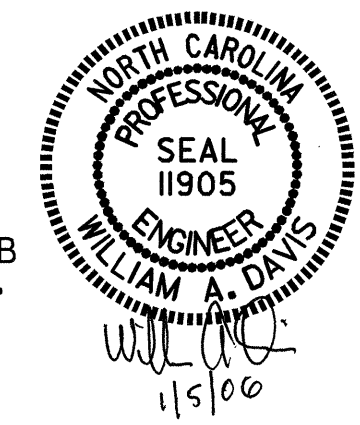

PROJECT NO. B-4152
HOKE COUNTY
STATION: 14+70.00 -L-
SHEET 1 OF 4

STATE OF NORTH CAROLINA
DEPARTMENT OF TRANSPORTATION
RALEIGH
STANDARD
3'-0" X 1'-9"
PRESTRESSED CONCRETE
CORED SLAB UNIT

REVISIONS					SHEET NO.
NO.	BY:	DATE:	NO.	BY:	DATE:
1			3		
2			4		

TOTAL SHEETS 26

ASSEMBLED BY :	J.G. KHARVA	DATE :	8/3/05
CHECKED BY :	W. A. DAVIS	DATE :	8/11/05
DRAWN BY :	WJH 4/89	REV. 8/16/99	RWW/LES
CHECKED BY :	FCJ 5/89	REV. 10/17/00	RWW/LES
		REV. 7/10/01	RWW/LES