

**STATE OF NORTH CAROLINA
DEPARTMENT OF TRANSPORTATION**

**SIGNING PLANS
ALAMANCE COUNTY**

LOCATION: I-85 NB AT EXIT 140

T.I.P.: U-2905 A

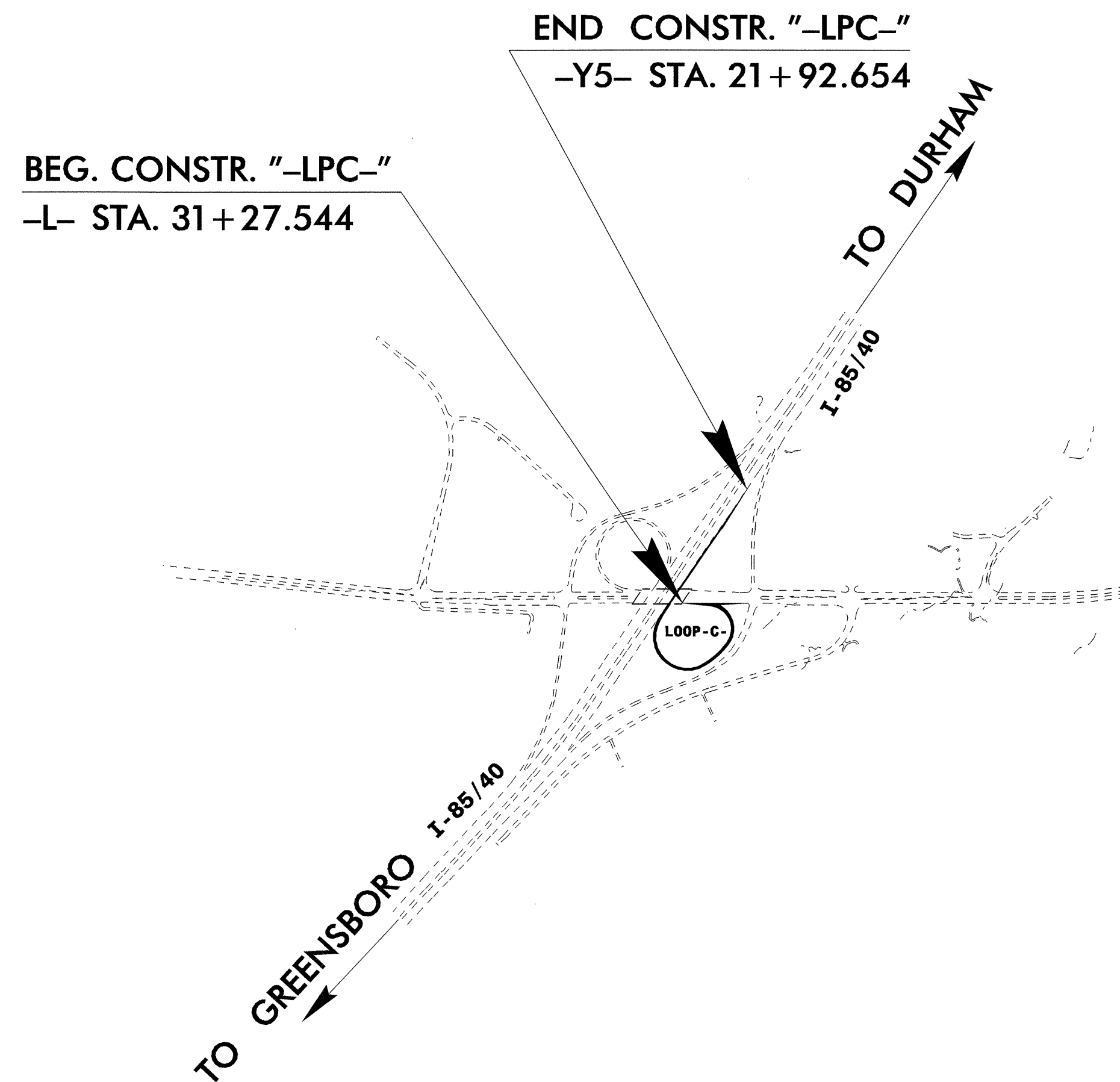

INDEX

SHEET NO.	DESCRIPTION
1	TITLE SHEET
2	SUMMARY OF QUANTITIES and applicable ROADWAY STANDARD DRAWINGS
2	NOTES
2	SUPPORT INFORMATION
3	E & F SHEETS
4	SIGN ROADWAY SHEET

PLAN PREPARED BY: N.C.D.O.T. SIGNING SECTION

RON KING, P.E. SIGNING ENGINEER

A. ALQUDWAH, P.E. SIGNING PROJECT ENGINEER

KELVIN L. JORDAN SIGNING PROJECT DESIGN ENGINEER

GEORGE M. TERLIZZI SIGNING DESIGNER

SEAL

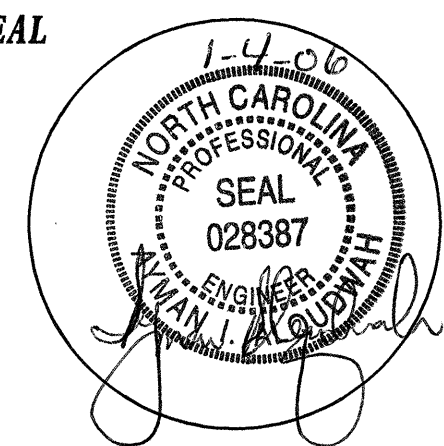

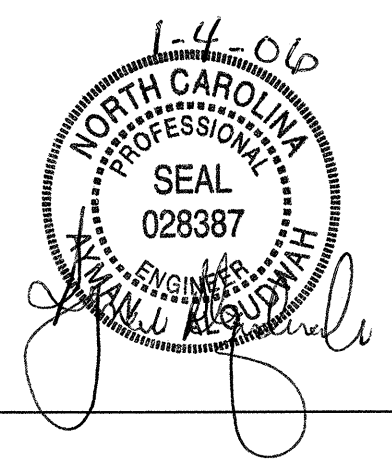
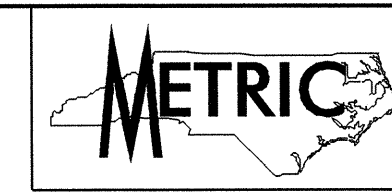

SIGNS SUMMARY OF QUANTITIES

NOTES

ITEM NO.		ITEM DESCRIPTION	QUANTITY	UNIT
DESC. NO.	SECT. NO.			
4054000000	902	PLAIN CONCRETE SIGN FOOTINGS	1	C.M.
4060000000	903	SUPPORTS, BREAKAWAY STEEL BEAM	123	KG.
4072000000	903	SUPPORTS, 4.5-KG STEEL U-CHANNEL	75	L.M.
4110000000	904	SIGN ERECTION, TYPE A (GROUND MOUNTED)	1	EA.
4096000000	904	SIGN ERECTION, TYPE D	3	EA.
4102000000	904	SIGN ERECTION, TYPE E	3	EA.
4108000000	904	SIGN ERECTION, TYPE F	4	EA.
4155000000	907	DISPOSAL OF SIGN SYSTEM, U-CHANNEL	3	EA.

Pay Item Notes:

1	DISPOSAL OF SIGN SYSTEM, U-CHANNEL
---	------------------------------------

General Notes:

- SIGNS FURNISHED BY STATE
- ALL TYPE 'D' SIGNS SHALL BE MOUNTED ON TWO U-CHANNEL POSTS UNLESS OTHERWISE INDICATED ON THE PLANS.
- IF REMOVAL OR RELOCATION OF SIGNS ON PRIVATE STREET (NON-STATE MAINTAINED) IS REQUIRED DUE TO CONSTRUCTION, THE CONTRACTOR SHALL INFORM THE ENGINEER. THE WORK WILL BE COMPLETED BY OTHERS.
- SIGNING PLANS DO NOT INCLUDE TEMPORARY CONSTRUCTION SIGNING OR PAVEMENT MARKINGS. SEE TRAFFIC CONTROL PLANS.
- WHEN NOT STATIONED OR DIMENSIONED ON PLANS, ALL 'E' AND 'F' SIGNS SHALL BE FIELD LOCATED BY THE ENGINEER
- THE BACKGROUND FOR TYPE E & F SIGNS SHALL BE TYPE III REFLECTIVE SHEETING.

TYPE "A" AND TYPE "B" GROUND MOUNTED SIGNS

SIGN NO.	SIGN TYPE	SIGN SIZE (in) w x h	ROADWAY STATION	NO. OF SUP.	BEAM SECTION	SUPPORT TYPE BA or S	HORIZ. CLR.* (ft.)	EXIT NUMBER ATTACH METHOD	LENGTH (ft)			LEFT SUPPORT (ft)			CENTER SUPPORT (ft)			RIGHT SUPPORT (ft)			B/A SUPPORT WEIGHTS (lbs.)	SIMPLE SUPPORT WEIGHTS (lbs.)	REINF. FTGS. (c.y.)	PLAIN FTGS. (c.y.)	FIELD VERIFIED SEE NOTE 2 (mm/dd/yy)
									SNS HT H	MTG HT C	EMBED-MENT	S	L	TOTAL LENGTH	S	L	TOTAL LENGTH	S	L	TOTAL LENGTH					
201	A	1800X1500	32+00	2	S100X11	BA	3.00	N/A	1.50	2.13	0.9662	0.15	3.75	4.75	N/A	0.00	0.00	0.21	3.83	4.83	122.01	0.00	0.0000	0.1560	
											TOTAL			TOTAL			TOTAL			TOTAL					
											122.01			0.00			0.0000			0.1560					
USE:											123			0			0			1					

- NOTES
- DIMENSION "S" REPRESENTS AN INCREASE (+), OR A DECREASE (-) IN POLE LENGTH, RELATIVE TO THE ELEVATION OF THE EDGE OF PAVEMENT.
 - FIELD VERIFICATIONS SHALL BE REQUIRED FOR ALL SUPPORTS, SEE (*) ARTICLE 903-3. FABRICATORS SHALL BE AISC CERTIFIED IN CATEGORY 1. SEE (*) ARTICLE 1072-1. (*) = N.C.D.O.T. STANDARD SPECIFICATIONS FOR ROADS AND STRUCTURES
 - PLAN LOCATIONS FOR EXISTING UTILITIES ARE BASED ON THE BEST AVAILABLE INFORMATION AND, THEREFORE MAY NOT BE PRECISELY ACCURATE. THEREFORE, IT IS INCUMBENT UPON THE CONTRACTOR TO DETERMINE THE EXACT LOCATION OF UTILITIES BEFORE BEGINNING WORK IN A LOCATION.

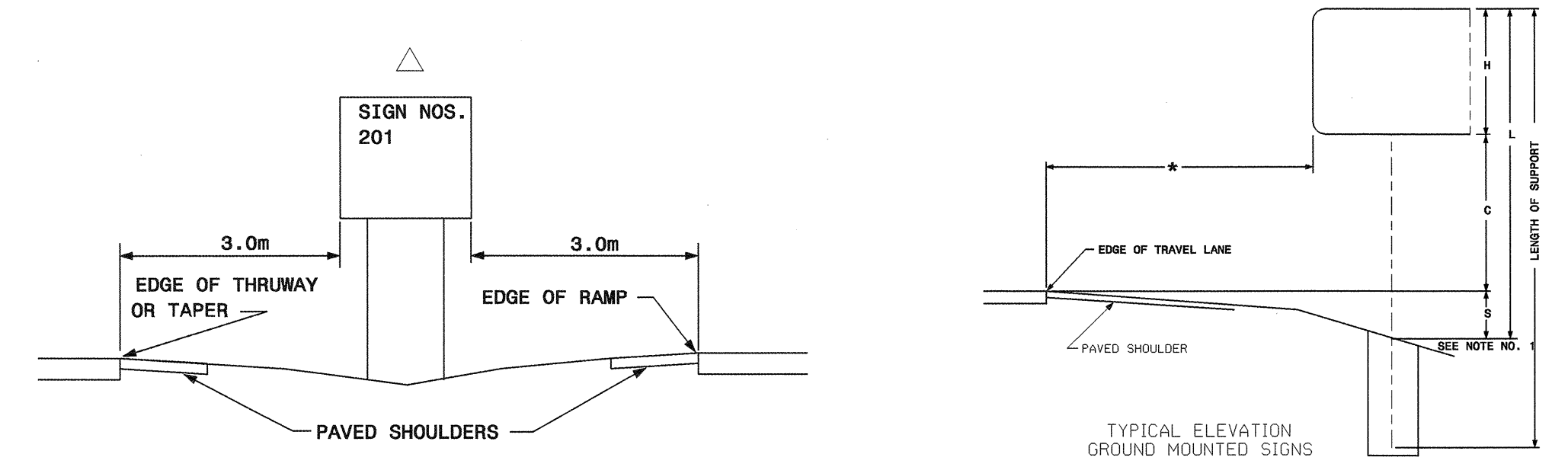

**ROADWAY STANDARD DRAWINGS
APPLICABLE TO THESE SIGNING PLANS**

901.20	903.10
901.50	904.10
901.70	904.50



401 QUANTITY REQ'D 1

1219 X 1219
W4-1 (R)

TWO "U" POSTS PER SIGN

501

EAST	NORTH	2 - 600 X 300
INTERSTATE 40	INTERSTATE 85	2 - 600 X 600
↗	↗	2 - 525 X 375

TWO "U" POSTS

402 QUANTITY REQ'D 1

1 - 610 X 610
D9-2

MOUNT ABOVE ASSY 501

ONE "U" POSTS PER SIGN

502

EAST	NORTH	2 - 600 X 300
INTERSTATE 40	INTERSTATE 85	2 - 600 X 600
↗	↗	2 - 525 X 375

TWO "U" POSTS
MOUNT BELOW SIGN 301

403 QUANTITY REQ'D 1

1 - 525 X 375
M6-3

MOUNT BELOW SIGN 402...
IN 1. INSTALLATION

503

WEST	SOUTH	2 - 600 X 300
INTERSTATE 40	INTERSTATE 85	2 - 600 X 600
↗	↗	2 - 525 X 375

TWO "U" POSTS

504

WEST	SOUTH	2 - 600 X 300
INTERSTATE 40	INTERSTATE 85	2 - 600 X 600
↗	↗	2 - 525 X 375

TWO "U" POSTS
MOUNT BELOW SIGN 303

NOTE: THIS DRAWING IS DIMENSIONED
IN MILLIMETERS UNLESS OTHERWISE
DEPICTED WITHIN THE DRAWING.

SEAL

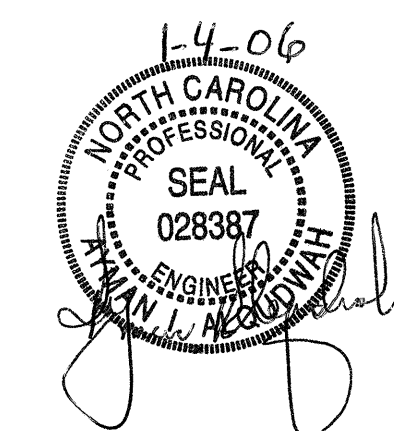

TYPE "E" & "F" SIGNS



TIP NO. U-2905 A	SHEET NO. SIGN- 4
---------------------	----------------------

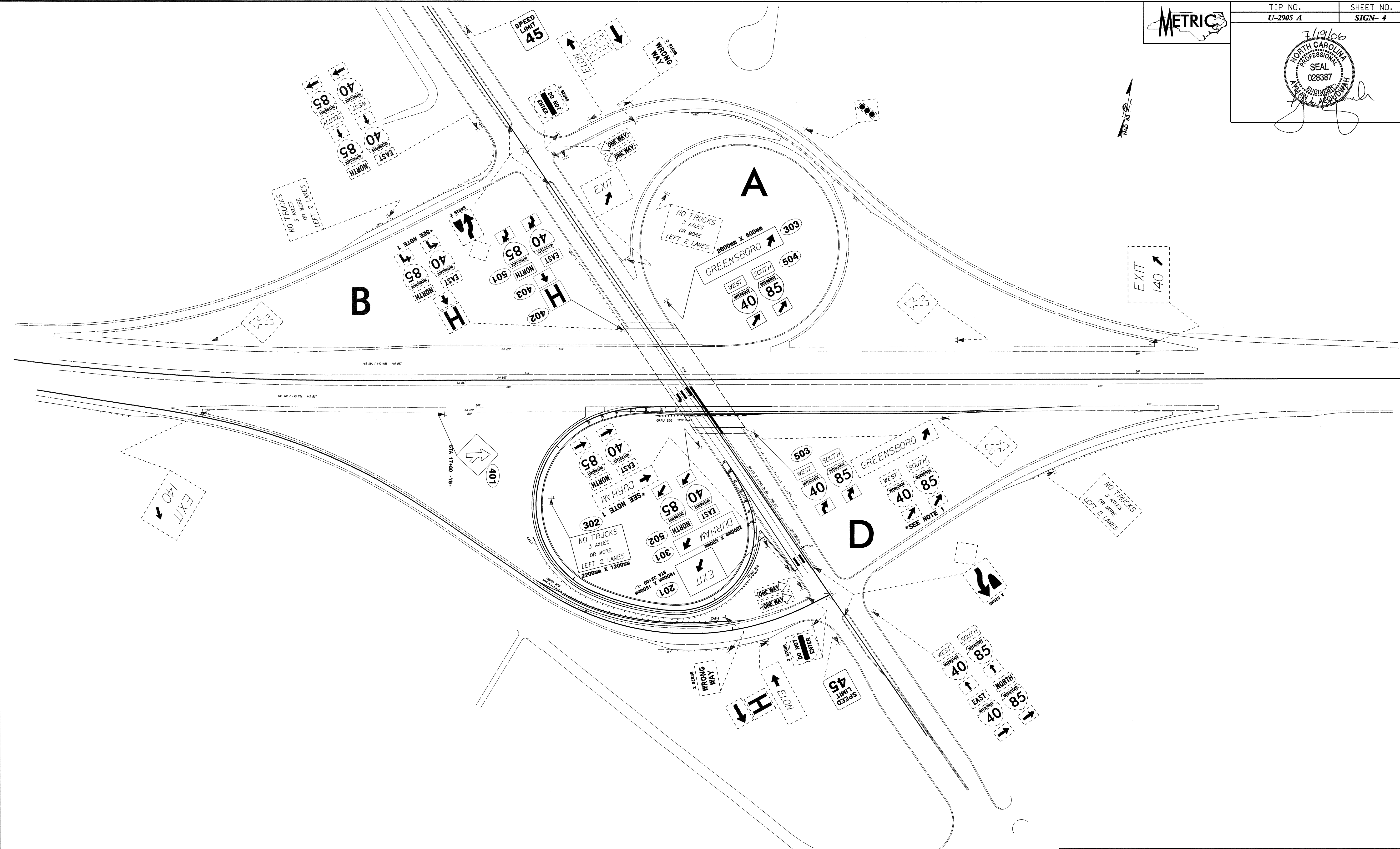
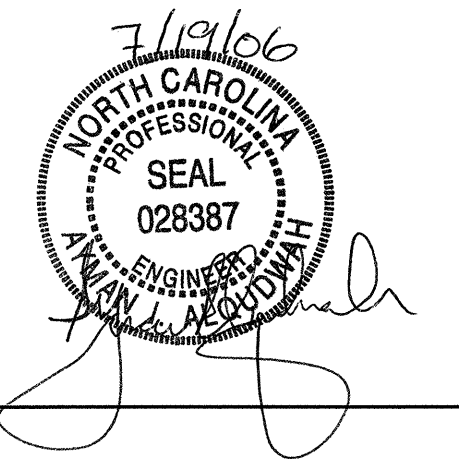

EXISTING AND PROPOSED SIGNS
 STA 29+00.000 -L- TO STA 32+60.000 -L-
 STA 17+00.000 -Y5- TO STA 22+00.000 -Y5-