

**NOTES**

STIRRUPS IN CAP MAY BE SHIFTED AS NECESSARY TO CLEAR DOWELS.

THE LATERAL GUIDE AT EACH END OF THE CAP IS NOT TO BE POURED UNTIL AFTER THE BOX BEAM UNITS ARE IN PLACE.

THE CONTRACTOR SHALL PROVIDE FOR INSTALLATION OF THE 4" DIAMETER DRAIN PIPE THROUGH THE WING WALL AS REQUIRED FOR REINFORCED BRIDGE APPROACH FILLS, SEE THE ROADWAY PLANS. REINFORCING STEEL IN THE WING WALL MAY BE SHIFTED AS NECESSARY TO CLEAR THE DRAIN PIPE.

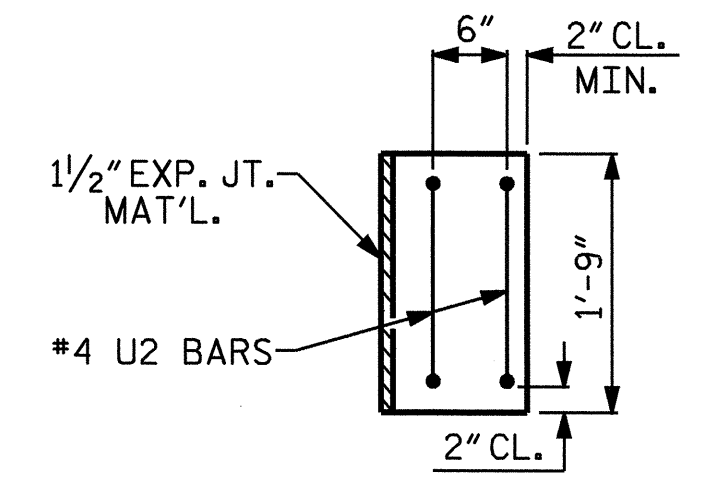

**LATERAL GUIDE**

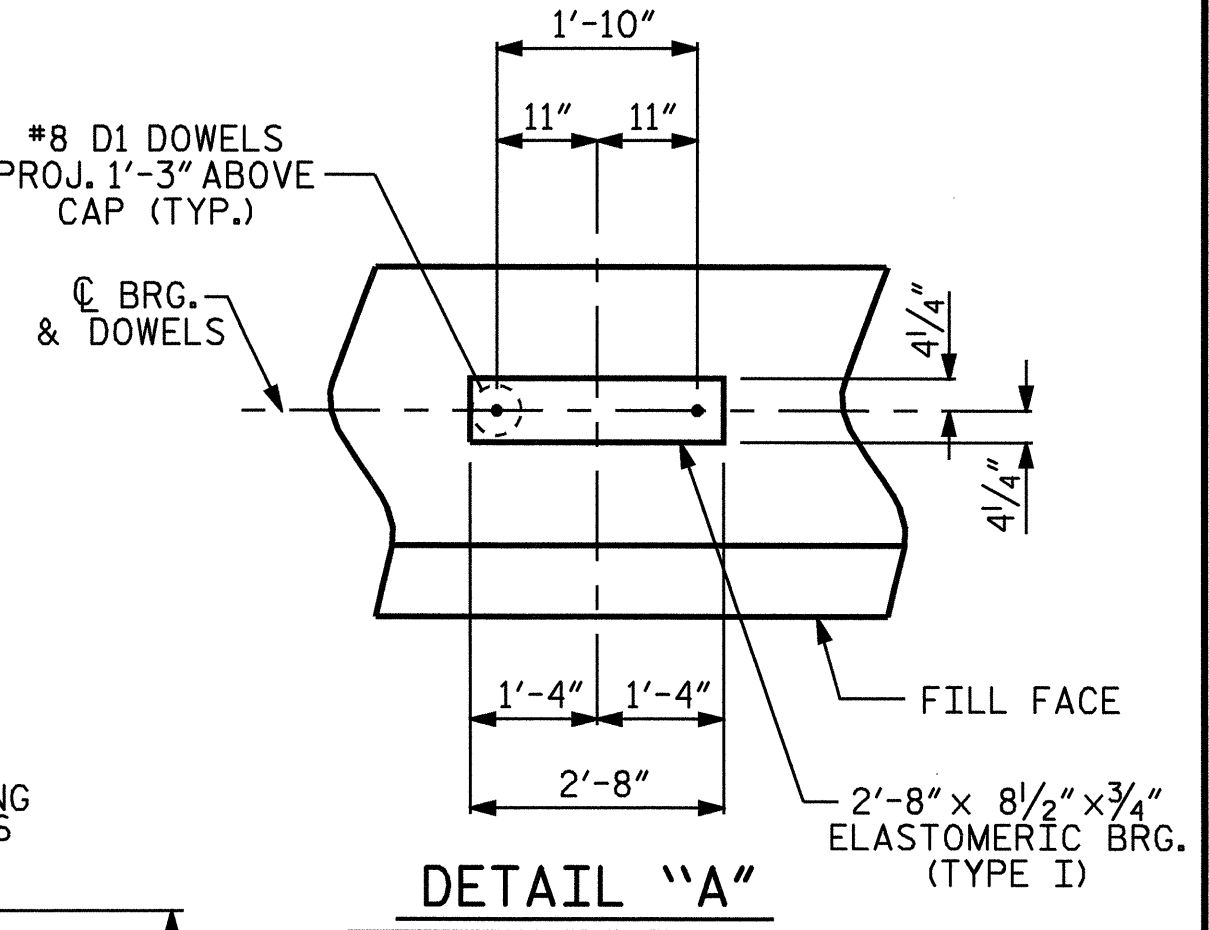

**DETAIL "A"**

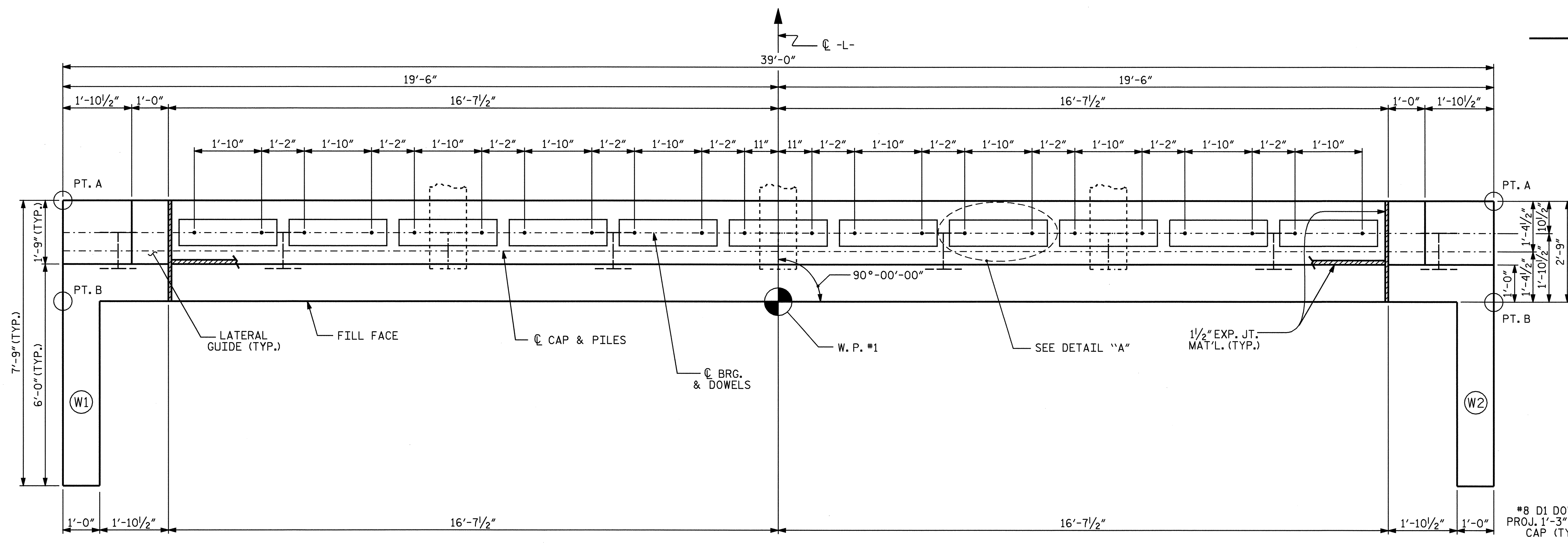

**PLAN**

ELEVATIONS OF NOTED POINTS:

POINT "A"	= 2512.481
POINT "B"	= 2512.376

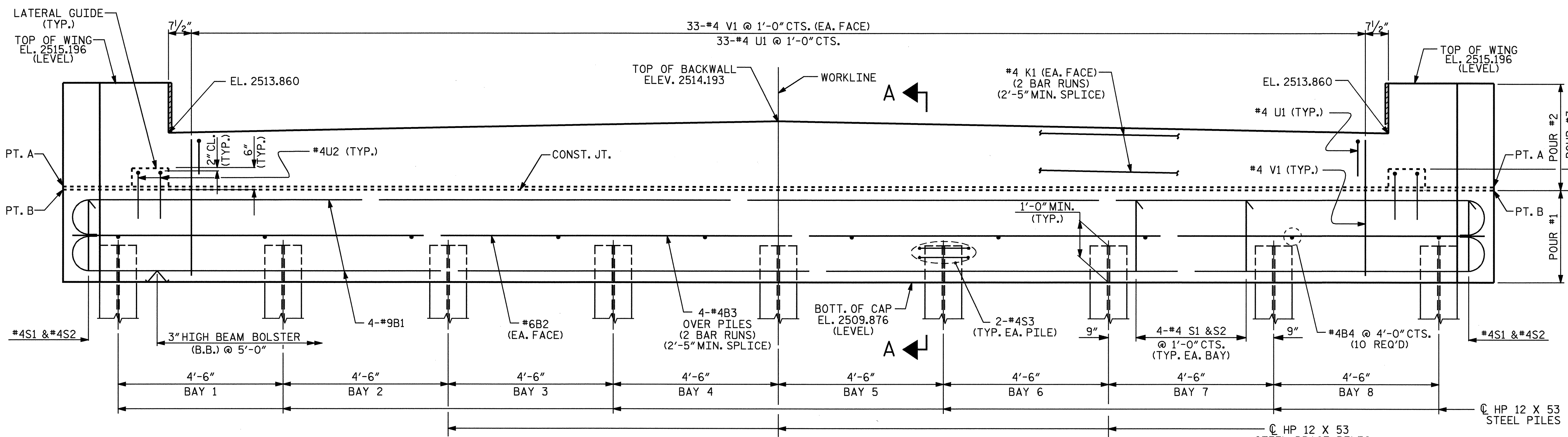

**ELEVATION**

PROJECT NO. B-4180  
MACON COUNTY  
 STATION: 17+06.00 -L-

SHEET 1 OF 3

STATE OF NORTH CAROLINA  
 DEPARTMENT OF TRANSPORTATION  
 RALEIGH

**SUBSTRUCTURE  
 END BENT #1**

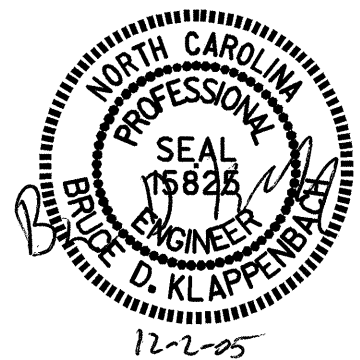

DRAWN BY: M. G. SHAIKH DATE: 01-11-05  
 CHECKED BY: J. B. WILSON DATE: 01-20-05

REVISIONS						SHEET NO.	
NO.	BY:	DATE:	NO.	BY:	DATE:	S-9	
1			3			TOTAL	18
2			4			SHEETS	