

NOTES

STIRRUPS IN CAP MAY BE SHIFTED AS NECESSARY TO CLEAR DOWELS.

THE LATERAL GUIDE AT EACH END OF THE CAP IS NOT TO BE POURED UNTIL AFTER THE CORED SLAB UNITS ARE IN PLACE.

THE CONTRACTOR SHALL PROVIDE FOR INSTALLATION OF THE 4" DIAMETER DRAIN PIPE THROUGH THE WING WALL AS REQUIRED FOR REINFORCED BRIDGE APPROACH FILLS, SEE THE ROADWAY PLANS. REINFORCING STEEL IN THE WING WALL MAY BE SHIFTED AS NECESSARY TO CLEAR THE DRAIN PIPE.

THE CONCRETE IN THE SHADED AREA OF THE WING SHALL BE POURED AFTER THE PARAPET AND END POST ARE CAST IF SLIP FORMING IS USED.

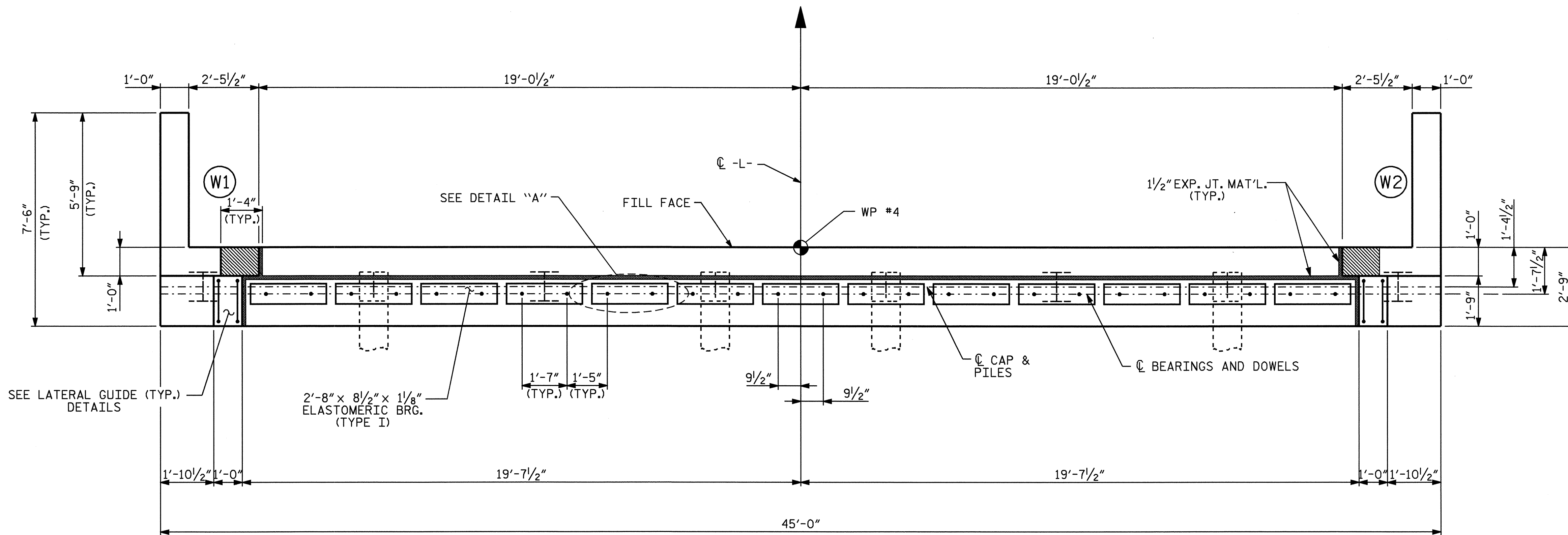

PLAN

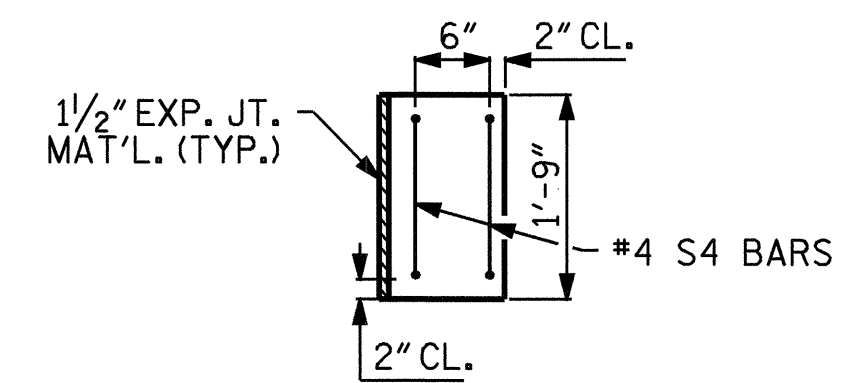

PLAN OF LATERAL GUIDE

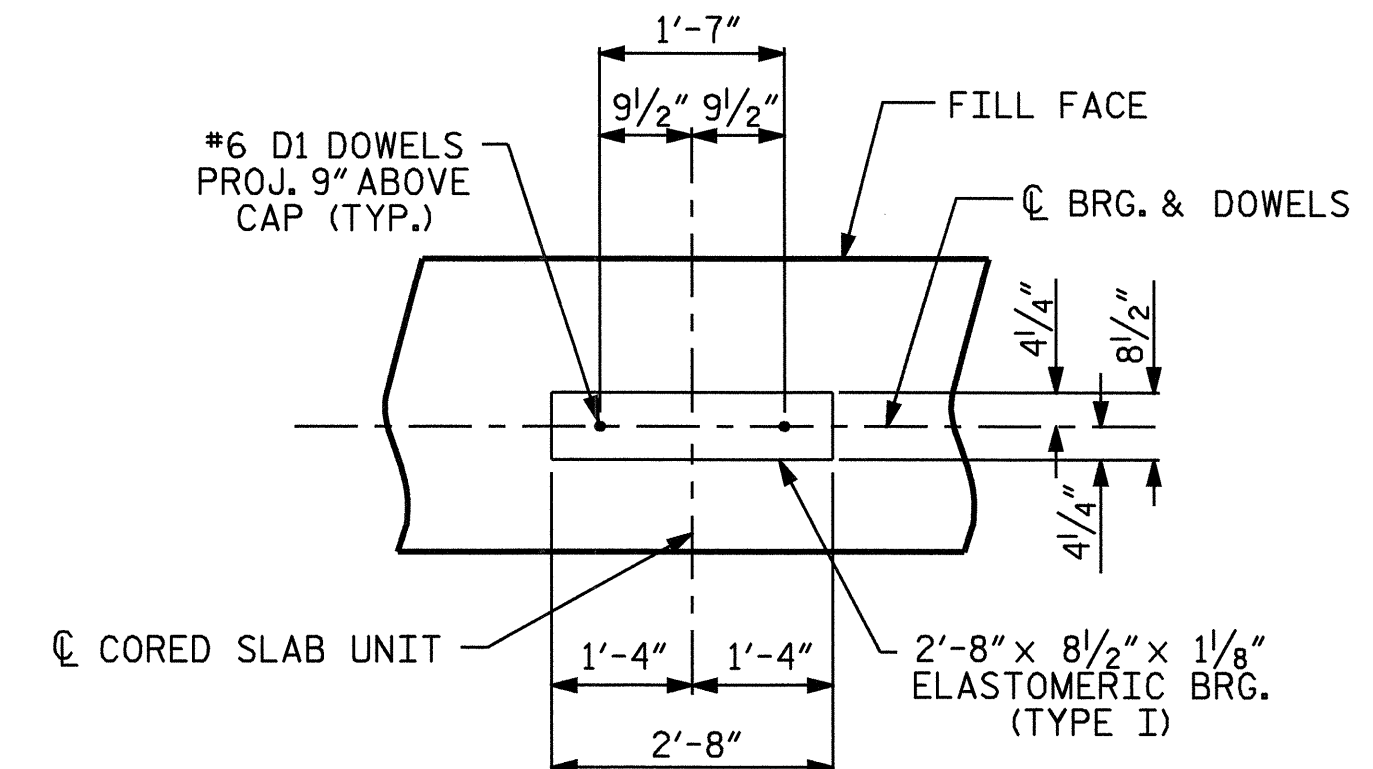

DETAIL "A"

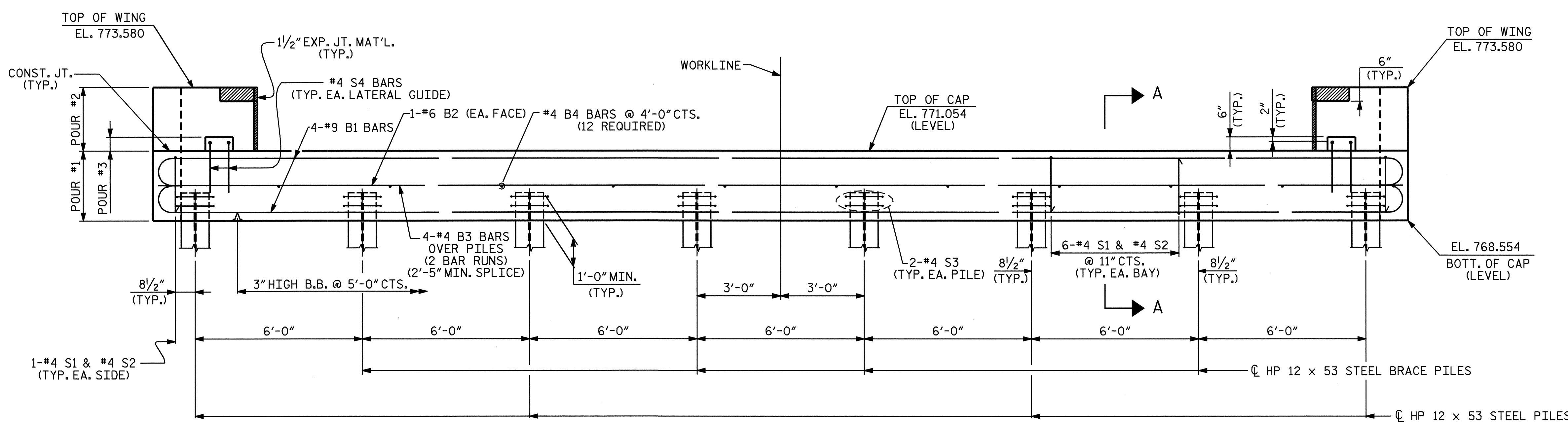

ELEVATION

PROJECT NO. B-3848
GUILFORD COUNTY
 STATION: 13+54.50 -L-

SHEET 1 OF 3

STATE OF NORTH CAROLINA
 DEPARTMENT OF TRANSPORTATION
 RALEIGH
**SUBSTRUCTURE
 END BENT #2**

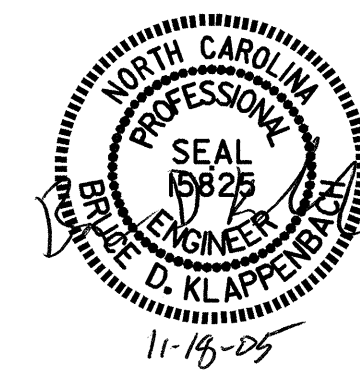

DRAWN BY : J.B. WILSON/M.G.S. DATE : 4/11/05
 CHECKED BY : D.A. GLADDEN DATE : 7/5/05

REVISIONS						SHEET NO.
NO.	BY:	DATE:	NO.	BY:	DATE:	5-22
1			3			TOTAL SHEETS
2			4			27