

NOTES

STIRRUPS IN CAP MAY BE SHIFTED AS NECESSARY TO CLEAR DOWELS.

THE LATERAL GUIDE AT EACH END OF THE CAP IS NOT TO BE POURED UNTIL AFTER THE CORED SLAB UNITS ARE IN PLACE.

THE CONTRACTOR SHALL PROVIDE FOR INSTALLATION OF THE 4" DIAMETER DRAIN PIPE THROUGH THE WING WALL AS REQUIRED FOR REINFORCED BRIDGE APPROACH FILLS, SEE THE ROADWAY PLANS. REINFORCING STEEL IN THE WING WALL MAY BE SHIFTED AS NECESSARY TO CLEAR THE DRAIN PIPE.

THE CONCRETE IN THE SHADED AREA OF THE WING SHALL BE POURED AFTER THE PARAPET AND END POST ARE CAST IF SLIP FORMING IS USED.

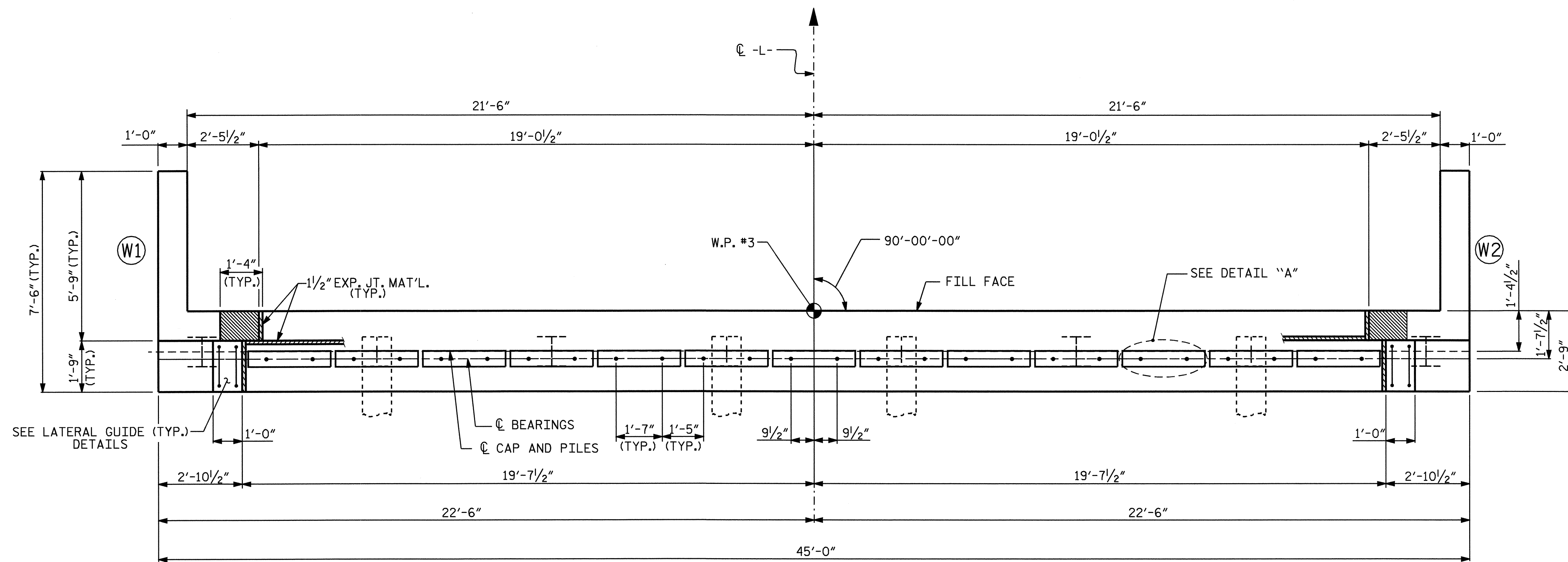

PLAN

PILE #	ELEVATION
PILE #1	815.893
PILE #2	816.013
PILE #3	816.133
PILE #4	816.253
PILE #5	816.373
PILE #6	816.493
PILE #7	816.613
PILE #8	816.733

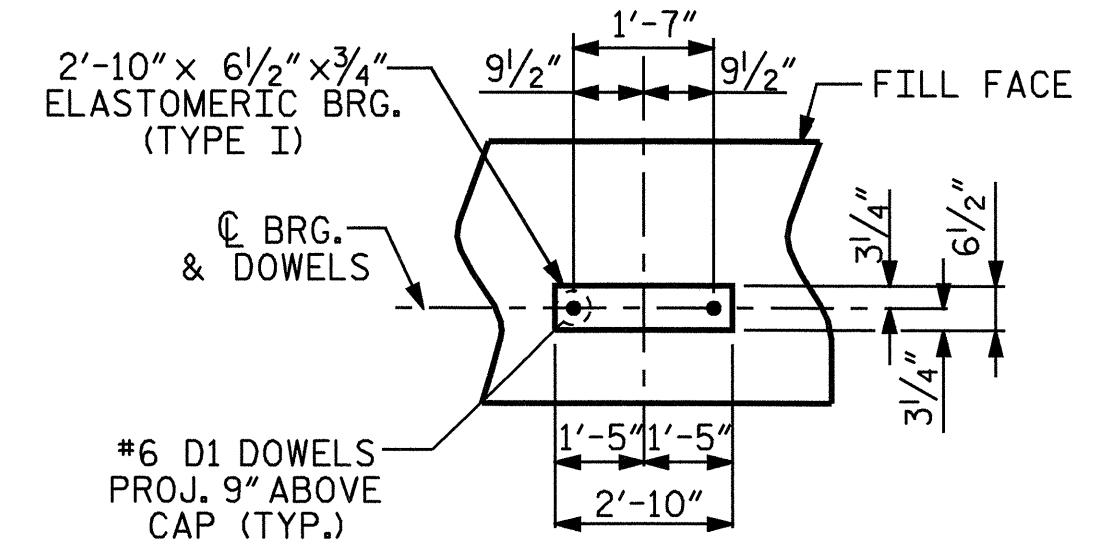

DETAIL "A"

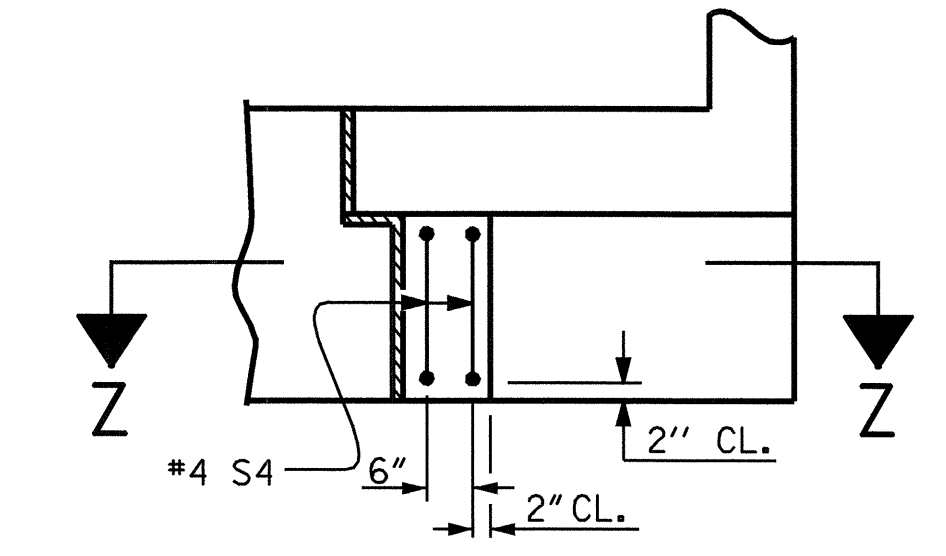

SECTION Z-Z

LATERAL GUIDE DETAILS

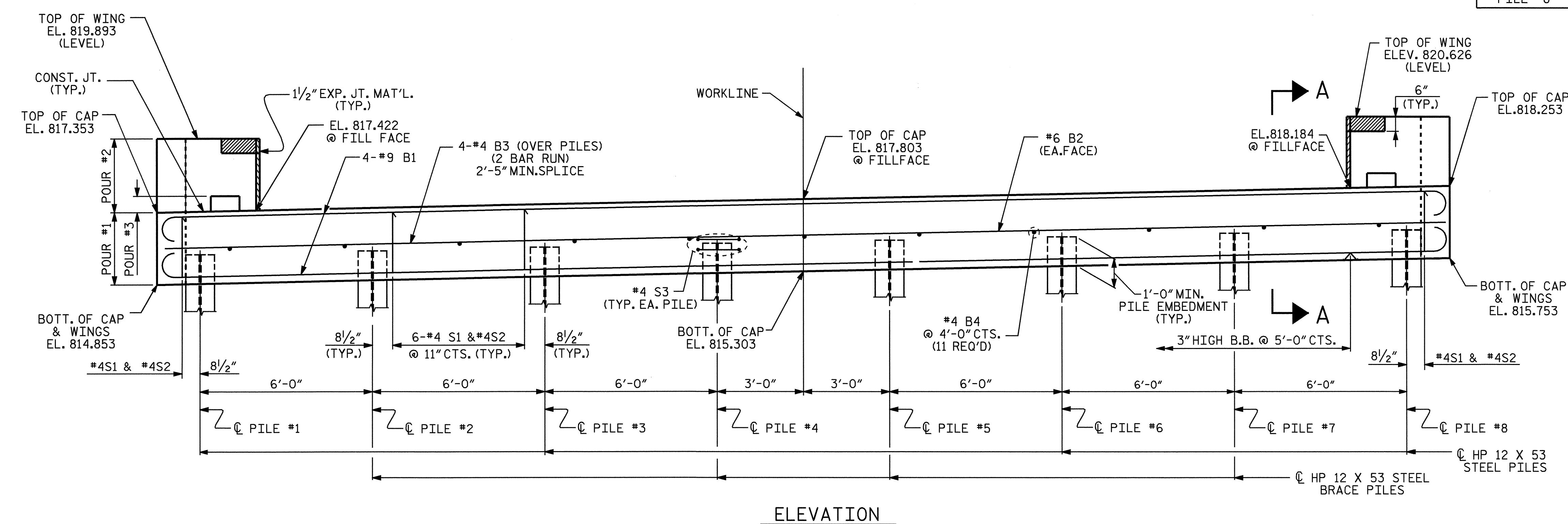

ELEVATION

PROJECT NO. B-3847
 GUILFORD COUNTY
 STATION: 14+60.00 -L-

SHEET 1 OF 3

STATE OF NORTH CAROLINA
 DEPARTMENT OF TRANSPORTATION
 RALEIGH

**SUBSTRUCTURE
 END BENT #2**

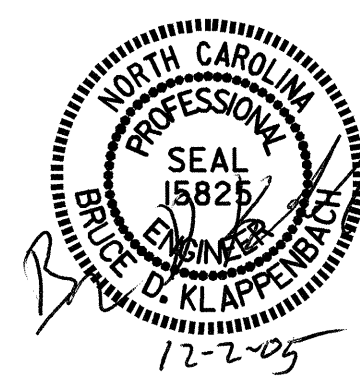

REVISIONS						SHEET NO. 5-18
NO.	BY:	DATE:	NO.	BY:	DATE:	
1			3			TOTAL SHEETS 23
2			4			

DRAWN BY: M. G. SHAIKH DATE: 05-10-05
 CHECKED BY: D. A. GLADDEN DATE: 10-17-05