

END ELEVATION

SHOWING PLACEMENT OF #5 & #4 "A" BARS AND LOCATION OF DOWEL HOLES. (INTERIOR BOX BEAM SECTION SHOWN-EXTERIOR SECTION SIMILAR EXCEPT SHEAR KEY LOCATION. STRAND LAYOUT NOT SHOWN.)

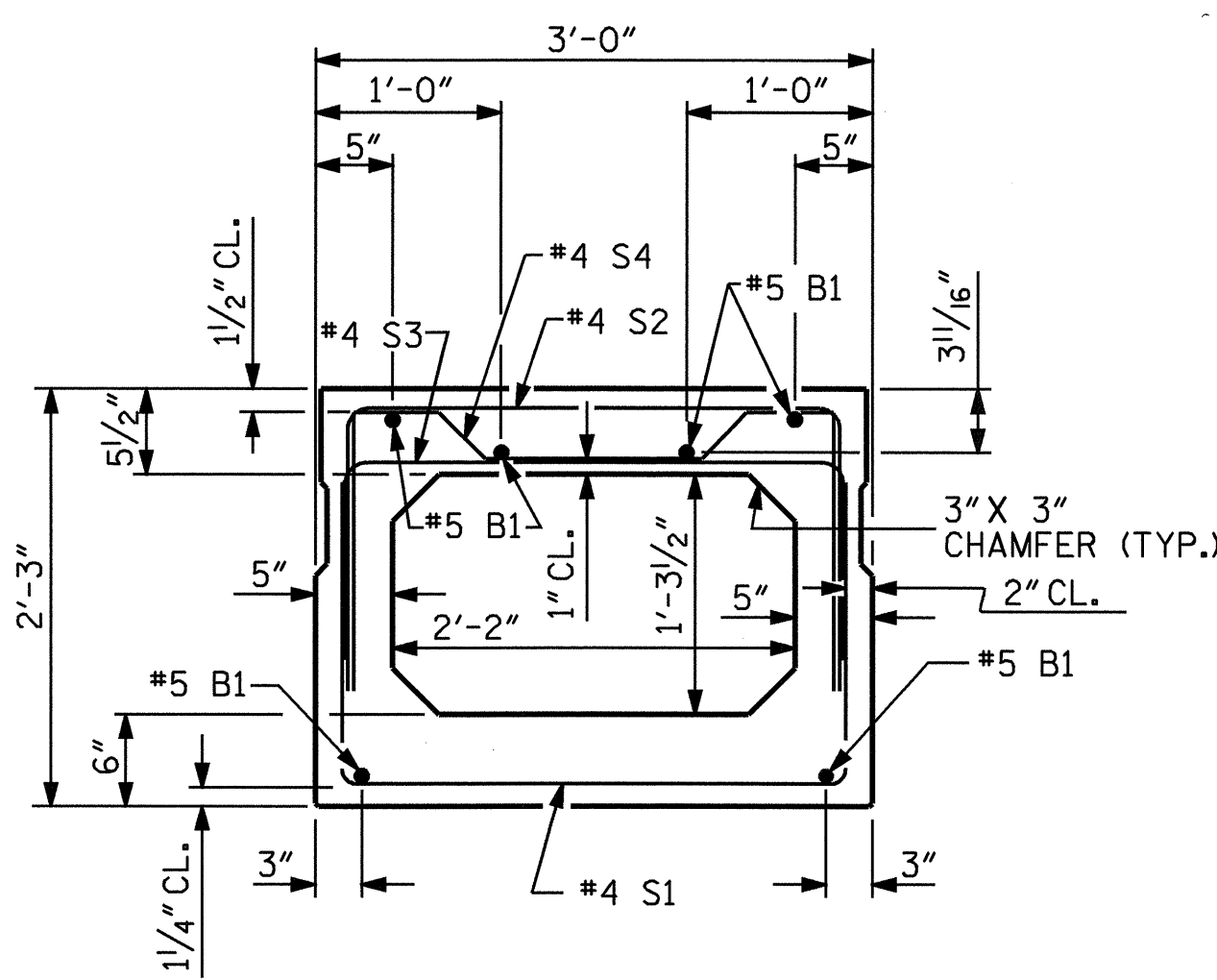

INTERIOR BOX BEAM SECTION

(STRAND LAYOUT NOT SHOWN)

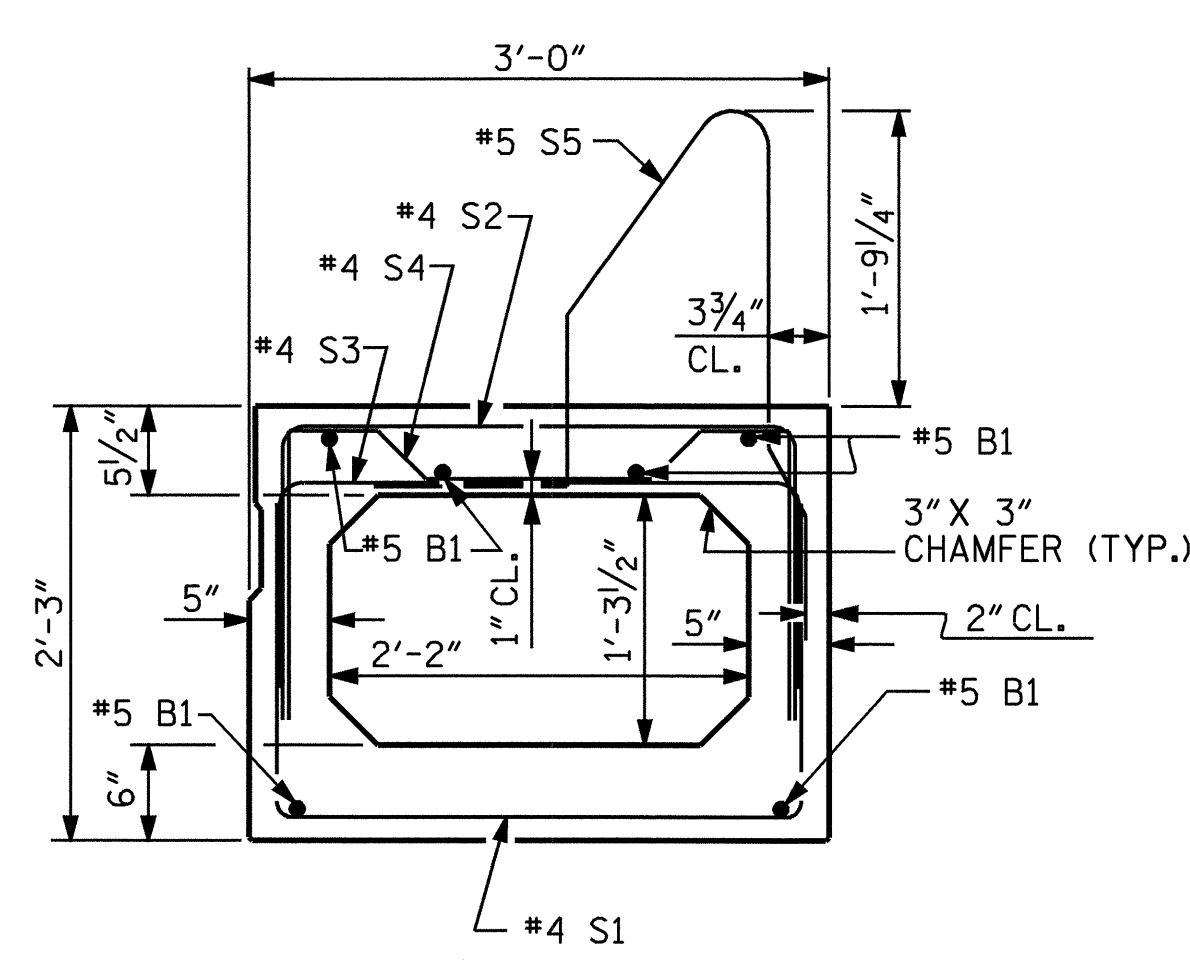

EXTERIOR BOX BEAM SECTION

(STRAND LAYOUT NOT SHOWN)

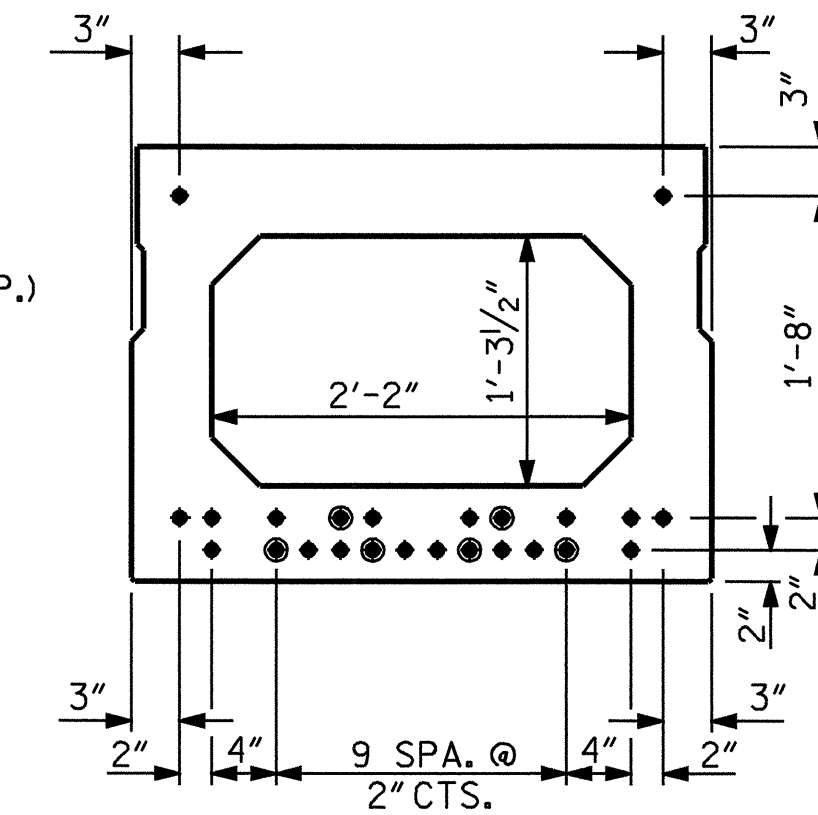

TYPICAL STRAND LOCATION

(24 STRANDS REQUIRED)
(INTERIOR BOX BEAM SECTION SHOWN-EXTERIOR SECTION SIMILAR EXCEPT SHEAR KEY LOCATION)

DEBONDING LEGEND

- FULLY BONDED STRANDS
- ⊙ STRANDS DEBONDED FOR 6'-0" FROM END OF GIRDER

0.6" Ø LOW RELAXATION STRAND LAYOUT

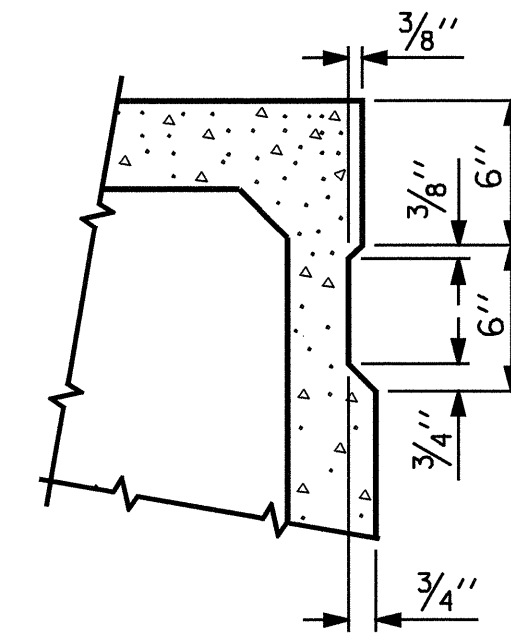

SHEAR KEY DETAIL

NOTE: OMIT SHEAR KEY ON OUTSIDE FACE OF EXTERIOR BOX BEAMS.

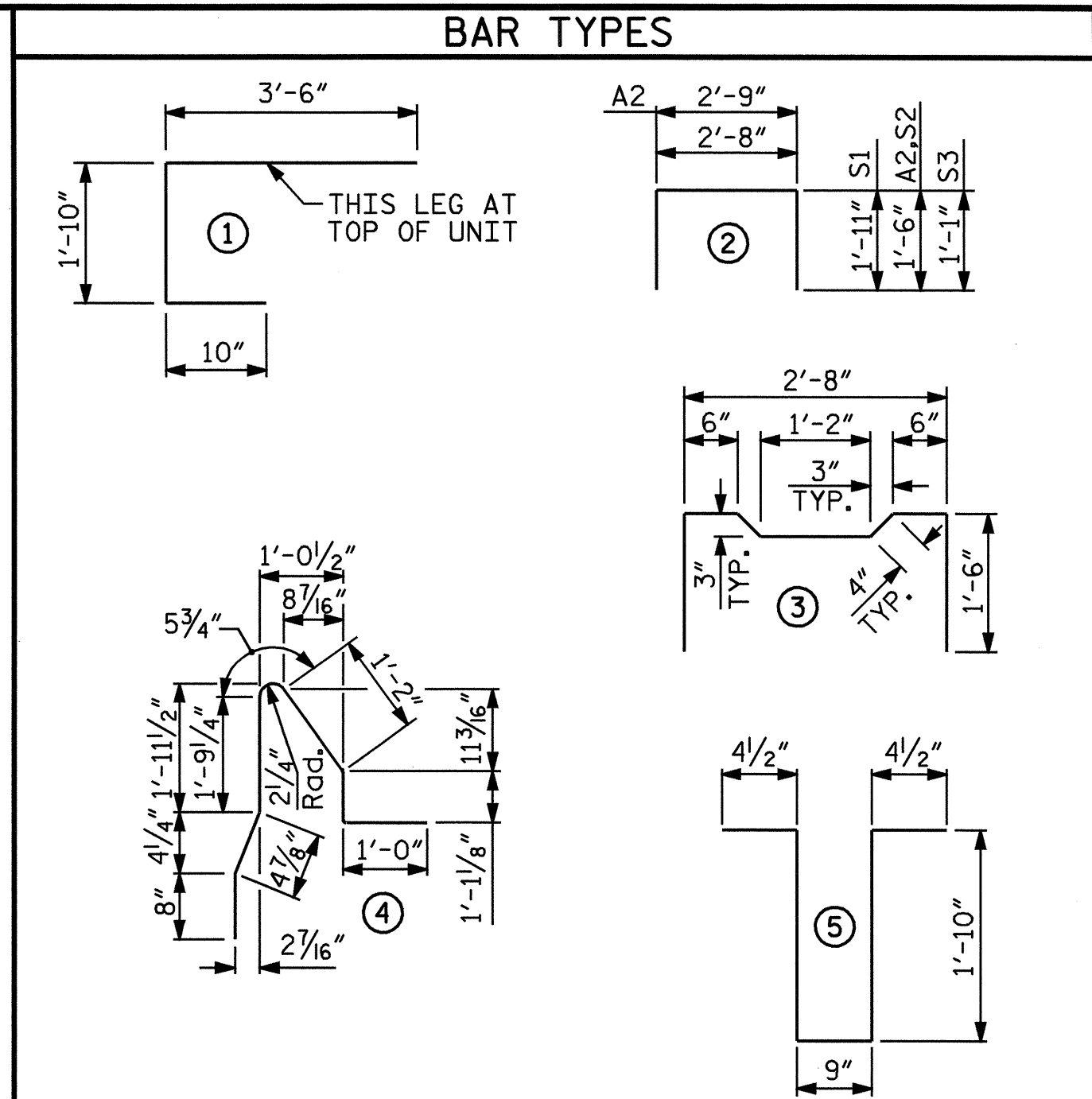

ALL BAR DIMENSIONS ARE OUT TO OUT

BILL OF MATERIAL FOR ONE BOX BEAM SECTION

BAR	NUMBER	SIZE	TYPE	EXTERIOR UNIT		INTERIOR UNIT	
				LENGTH	WEIGHT	LENGTH	WEIGHT
A1	10	#5	1	6'-2"	64	6'-2"	64
A2	14	#4	2	5'-9"	54	5'-9"	54
B1	6	#5	STR	59'-6"	372	59'-6"	372
D1	6	#4	5	5'-2"	21	5'-2"	21
D2	4	#4	STR	2'-7"	7	2'-7"	7
S1	58	#4	2	6'-6"	252	6'-6"	252
S2	58	#4	2	5'-8"	220	5'-8"	220
S3	99	#4	2	4'-10"	320	4'-10"	320
S4	41	#4	3	5'-10"	160	5'-10"	160
* S5	80	#5	4	6'-7"	549	--	--
REINFORCING STEEL				1470 LBS.		1470 LBS.	
* EPOXY COATED REINF. STEEL				549 LBS.			
7500 P.S.I. CONCRETE				9.4 CU. YDS.		9.4 CU. YDS.	
0.6" Ø L.R. STRANDS				No.	24	No.	24

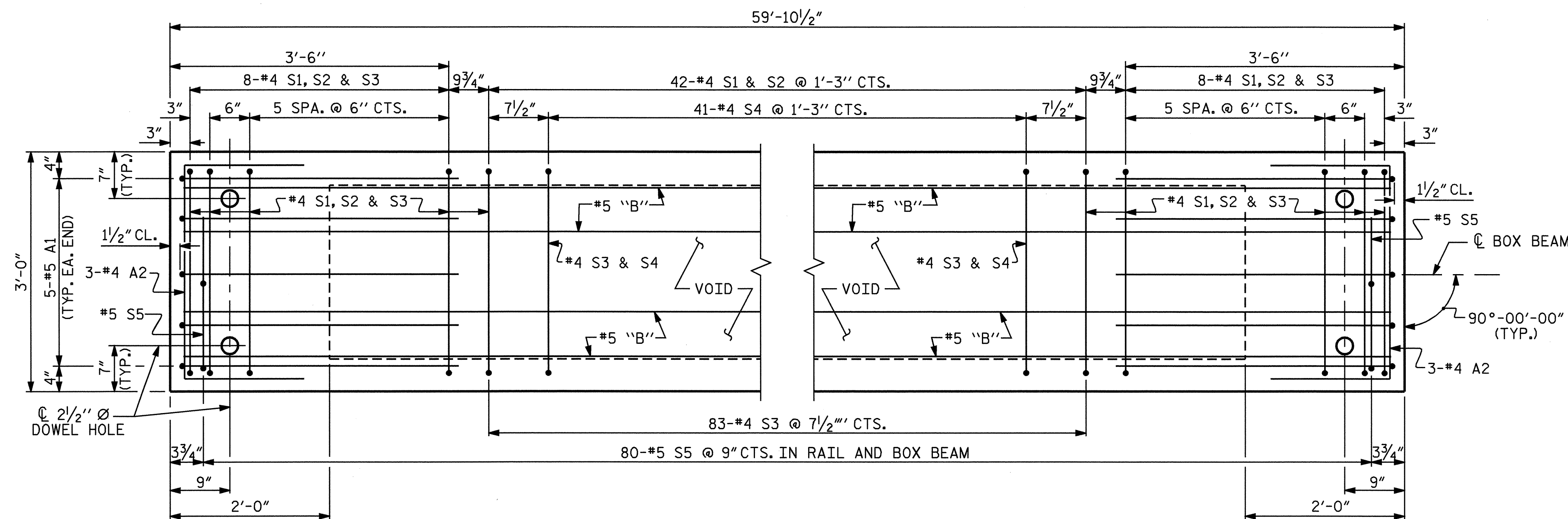

PLAN OF BOX BEAM

EXTERIOR UNIT SHOWN, INTERIOR UNIT SIMILAR EXCEPT OMIT #5 S5 BARS. FOR LOCATION OF DIAPHRAGMS, SEE PLAN OF SPANS. FOR REINFORCING STEEL IN DIAPHRAGMS, SEE DIAPHRAGM DETAILS.

PROJECT NO. B-1303
NORTHAMPTON COUNTY
 STATION: 18+81.00 -L-

SHEET 5 OF 7

STATE OF NORTH CAROLINA
 DEPARTMENT OF TRANSPORTATION
 RALEIGH
 STANDARD
 3'-0" X 2'-3"
 PRESTRESSED CONCRETE
 BOX BEAM UNIT
 SPANS A, B, & C



REVISIONS						SHEET NO. S-8
NO.	BY:	DATE:	NO.	BY:	DATE:	
1			3			TOTAL SHEETS 20
2			4			

ASSEMBLED BY : B.N. GRADY DATE : 5/05
 CHECKED BY : A.R. CHESSON DATE : 6/05

14-JUN-2005 11:15
 R:\STRUCTURE\B1303\B1303\BGRADY\Microstation\B1303.sd_pcb.01.dgn
 bng-rady

STD. NO. PCBB2