

BILL OF MATERIAL					
SPAN A					
BAR	NO.	SIZE	TYPE	LENGTH	WEIGHT
*A1	60	#5	STR	18'- 5"	1153
A2	60	#5	STR	18'- 5"	1153
*A101	2	#5	STR	15'-11"	33
*A102	2	#5	STR	13'- 4"	28
*A103	2	#5	STR	10'- 9"	22
*A104	2	#5	STR	8'- 2"	17
*A105	2	#5	STR	5'- 7"	12
*A106	2	#5	STR	3'- 0"	6
A201	2	#5	STR	15'-11"	33
A202	2	#5	STR	13'- 4"	28
A203	2	#5	STR	10'- 9"	22
A204	2	#5	STR	8'- 2"	17
A205	2	#5	STR	5'- 7"	12
A206	2	#5	STR	3'- 0"	6
*B1	26	#4	STR	24'- 6"	426
B2	17	#5	STR	47'- 0"	833
*B9	12	#4	STR	24'- 6"	196
*D1	67	#6	STR	1'- 6"	151
*D2	36	#4	STR	9"	18
*E1	2	#7	4	3'- 5"	14
*E2	2	#7	4	4'- 0"	16
*E3	2	#7	4	4'- 7"	19
*E4	2	#7	4	5'- 1"	21
*F1	1	#6	STR	3'- 2"	5
*F2	2	#6	STR	3'- 6"	11
*F3	1	#6	STR	3'- 9"	6
*F4	1	#6	STR	3'- 5"	5
*F5	2	#6	STR	3'- 9"	11
*F6	1	#6	STR	4'- 0"	6
*G1	2	#5	STR	19'- 0"	40
*G2	45	#4	STR	6'- 3"	188
*G3	2	#4	STR	6'- 5"	9
*J1	18	#4	5	1'- 5"	17
*K1	4	#5	1	7'- 9"	32
*K2	4	#5	2	10'- 5"	43
*K3	4	#5	1	8'-10"	37
*S1	20	#4	3	3'- 4"	45
REINFORCING STEEL = 2104 LBS					
*EPOXY COATED REINF. STEEL = 2587 LBS					

BILL OF MATERIAL					
SPAN B					
BAR	NO.	SIZE	TYPE	LENGTH	WEIGHT
*A1	157	#5	STR	18'- 5"	3016
A2	157	#5	STR	18'- 5"	3016
*A101	2	#5	STR	15'-11"	33
*A102	2	#5	STR	13'- 4"	28
*A103	2	#5	STR	10'- 9"	22
*A104	2	#5	STR	8'- 2"	17
*A105	2	#5	STR	5'- 7"	12
*A106	2	#5	STR	3'- 0"	6
A201	2	#5	STR	15'-11"	33
A202	2	#5	STR	13'- 4"	28
A203	2	#5	STR	10'- 9"	22
A204	2	#5	STR	8'- 2"	17
A205	2	#5	STR	5'- 7"	12
A206	2	#5	STR	3'- 0"	6
*B3	65	#4	STR	24'- 9"	1075
B4	51	#5	STR	40'- 1"	2132
*B10	30	#4	STR	24'- 9"	496
*D1	164	#6	STR	1'- 6"	369
*D2	76	#4	STR	9"	38
*G1	2	#5	STR	19'- 0"	40
*G2	113	#4	STR	6'- 3"	472
*G3	2	#4	STR	6'- 5"	9
*J1	36	#4	5	1'- 5"	34
*K4	4	#5	1	7'- 11"	33
*K5	4	#5	2	10'- 9"	45
*K6	4	#5	1	9'-0"	38
*S1	20	#4	3	3'- 4"	45
REINFORCING STEEL = 5266 LBS					
*EPOXY COATED REINF. STEEL = 5828 LBS					

BILL OF MATERIAL					
SPAN C					
BAR	NO.	SIZE	TYPE	LENGTH	WEIGHT
*A1	117	#5	STR	18'- 5"	2247
A2	117	#5	STR	18'- 5"	2247
*A101	2	#5	STR	15'-11"	33
*A102	2	#5	STR	13'- 4"	28
*A103	2	#5	STR	10'- 9"	22
*A104	2	#5	STR	8'- 2"	17
*A105	2	#5	STR	5'- 7"	12
*A106	2	#5	STR	3'- 0"	6
A201	2	#5	STR	15'-11"	33
A202	2	#5	STR	13'- 4"	28
A203	2	#5	STR	10'- 9"	22
A204	2	#5	STR	8'- 2"	17
A205	2	#5	STR	5'- 7"	12
A206	2	#5	STR	3'- 0"	6
*B5	52	#4	STR	23'- 4"	811
B6	34	#5	STR	44'-10"	1590
*B11	24	#4	STR	23'- 4"	374
*D1	124	#6	STR	1'- 6"	279
*D2	60	#4	STR	9"	30
*G1	2	#5	STR	19'- 0"	40
*G2	85	#4	STR	6'- 3"	355
*G3	2	#4	STR	6'- 5"	9
*J1	36	#4	5	1'- 5"	34
*K1	4	#5	1	7'- 9"	32
*K2	4	#5	2	10'- 5"	43
*K3	4	#5	1	8'-10"	37
*S1	20	#4	3	3'- 4"	45
REINFORCING STEEL = 3955 LBS					
*EPOXY COATED REINF. STEEL = 4454 LBS					

BILL OF MATERIAL					
SPAN D					
BAR	NO.	SIZE	TYPE	LENGTH	WEIGHT
*A1	48	#5	STR	18'- 5"	922
A2	48	#5	STR	18'- 5"	922
*A101	2	#5	STR	15'-11"	33
*A102	2	#5	STR	13'- 4"	28
*A103	2	#5	STR	10'- 9"	22
*A104	2	#5	STR	8'- 2"	17
*A105	2	#5	STR	5'- 7"	12
*A106	2	#5	STR	3'- 0"	6
A201	2	#5	STR	15'-11"	33
A202	2	#5	STR	13'- 4"	28
A203	2	#5	STR	10'- 9"	22
A204	2	#5	STR	8'- 2"	17
A205	2	#5	STR	5'- 7"	12
A206	2	#5	STR	3'- 0"	6
*B7	26	#4	STR	20'- 5"	355
B8	17	#5	STR	38'-10"	689
*B12	12	#4	STR	20'- 5"	164
*D1	55	#6	STR	1'- 6"	124
*D2	32	#4	STR	9"	16
*E1	2	#7	4	3'- 5"	14
*E2	2	#7	4	4'- 0"	16
*E3	2	#7	4	4'- 7"	19
*E4	2	#7	4	5'- 1"	21
*F1	1	#6	STR	3'- 2"	5
*F2	2	#6	STR	3'- 6"	11
*F3	1	#6	STR	3'- 9"	6
*F4	1	#6	STR	3'- 5"	5
*F5	2	#6	STR	3'- 9"	11
*F6	1	#6	STR	4'- 0"	6
*G1	2	#5	STR	19'- 0"	40
*G2	36	#4	STR	6'- 3"	150
*G3	2	#4	STR	6'- 5"	9
*J1	18	#4	5	1'- 5"	17
*K1	4	#5	1	7'- 9"	32
*K2	4	#5	2	10'- 5"	43
*K3	4	#5	1	8'-10"	37
*S1	20	#4	3	3'- 4"	45
REINFORCING STEEL = 1729 LBS					
*EPOXY COATED REINF. STEEL = 2186 LBS					

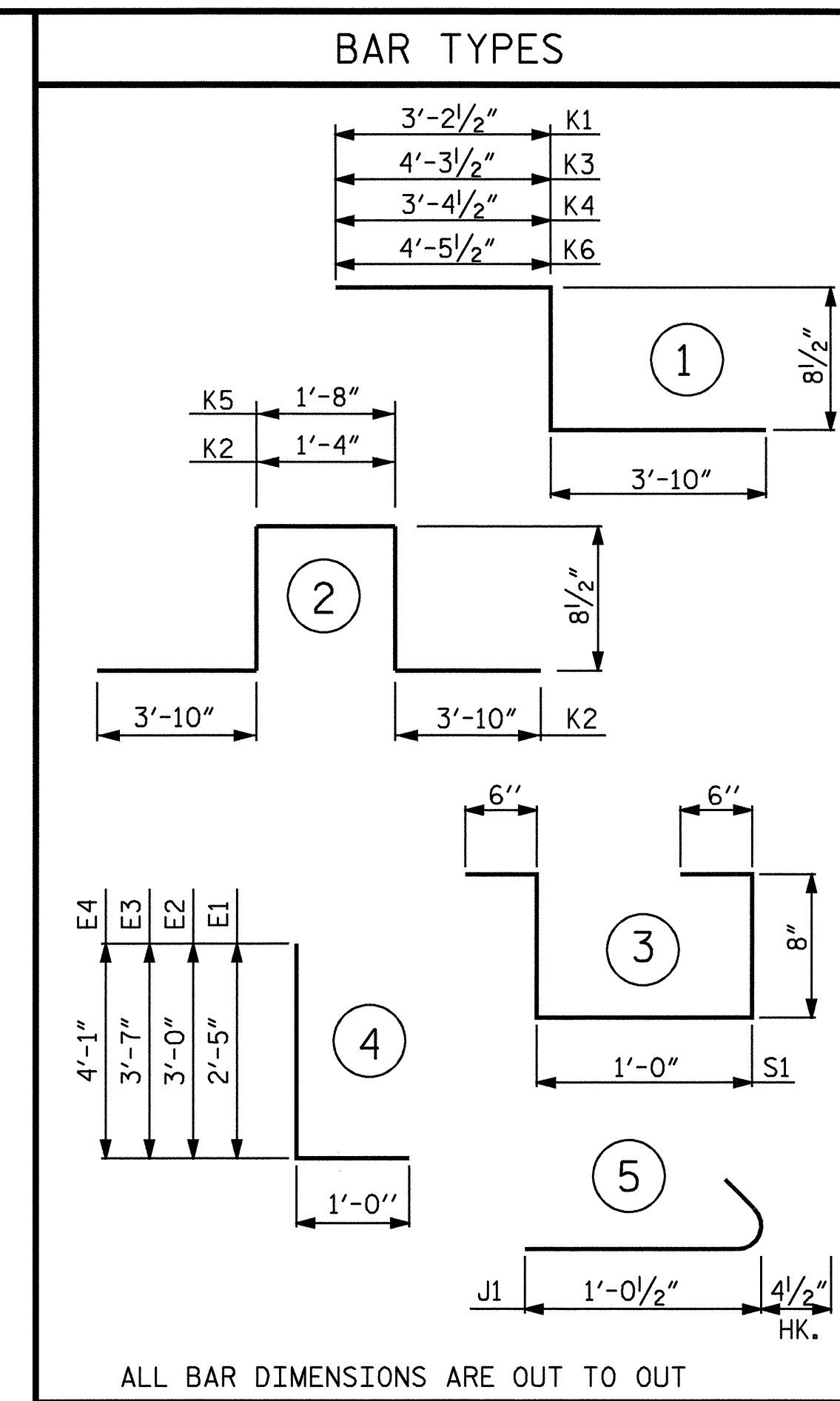

ALL BAR DIMENSIONS ARE OUT TO OUT

GROOVING BRIDGE FLOORS	
BRIDGE DECK	3023 SQ.FT.
APPROACH SLABS	2360 SQ.FT.
TOTAL	5383 SQ.FT.

BAR SIZE	SUPERSTRUCTURE REINFORCING STEEL LENGTHS ARE BASED ON THE FOLLOWING MINIMUM SPLICE LENGTHS				PARAPET AND BARRIER RAIL
	SUPERSTRUCTURE EXCEPT APPROACH SLABS, PARAPET, AND BARRIER RAIL		APPROACH SLABS		
	EPOXY COATED	UNCOATED	EPOXY COATED	UNCOATED	
#4	2'-0"	1'-9"	2'-0"	1'-9"	2'-9"
#5	2'-6"	2'-2"	2'-6"	2'-2"	3'-5"
#6	3'-0"	2'-7"	3'-10"	2'-7"	4'-4"
#7	5'-3"	3'-6"			
#8	6'-10"	4'-7"			

	SUPERSTRUCTURE BILL OF MATERIAL		
	CLASS AA CONCRETE (CU.YDS.)	REINFORCING STEEL (LBS.)	EPOXY COATED REINFORCING STEEL (LBS.)
SPAN "A"	27.3	2104	2587
SIDEWALK	8.2	***	***
END POST	0.4	***	***
SPAN "B"	66.4	5266	5828
SIDEWALK	20.1	***	***
SPAN "C"	50.1	3955	4454
SIDEWALK	15.2	***	***
SPAN "D"	22.8	1729	2186
SIDEWALK	6.8	***	***
END POST	0.4	***	***
TOTALS	217.7	13054	15055

\*\*\*SIDEWALK & END POST REINFORCING STEEL IS INCLUDED IN SPAN QUANTITIES.

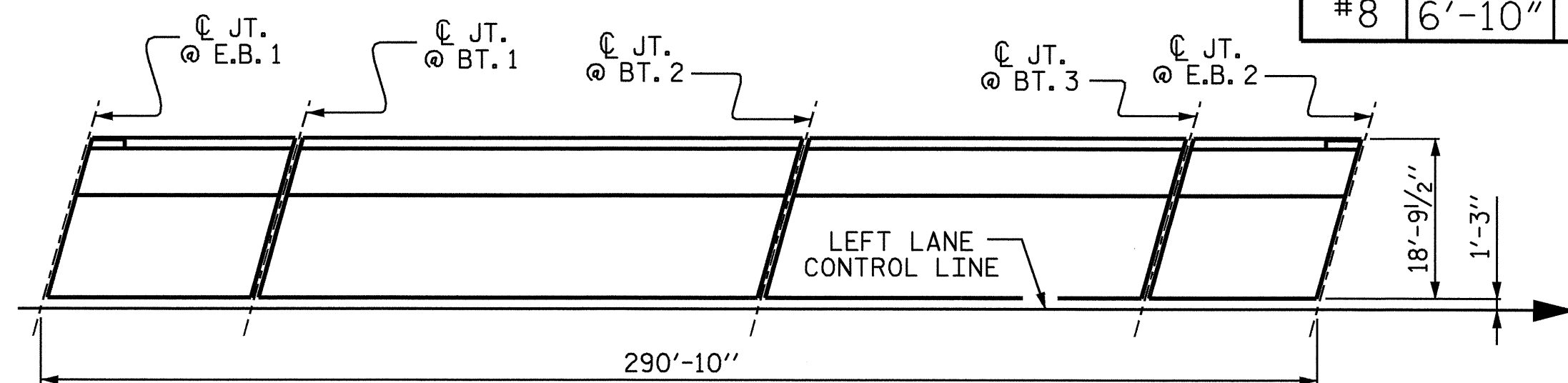
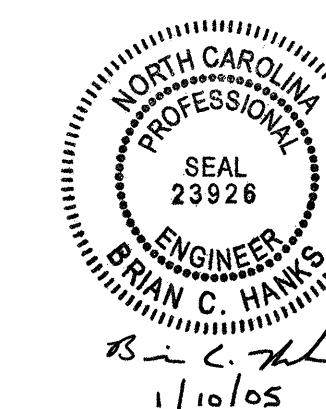

LAYOUT FOR COMPUTING AREA OF REINFORCED CONCRETE DECK SLAB (TOTAL = 5465 SQ. FT.)

DRAWN BY: William J. Parker DATE: 02/03/04  
 CHECKED BY: K. K. PUROHIT DATE: 5/25/04

07-JAN-2005 15:06  
 W:\squadg\TURNED\U3837\FINAL\STR\U3837.sd.bom.01.dgn  
 kalford

PROJECT NO. U-3837  
 FORSYTH COUNTY  
 STATION: 21+64.07 -L-

STATE OF NORTH CAROLINA  
 DEPARTMENT OF TRANSPORTATION  
 RALEIGH  
 SUPERSTRUCTURE  
 BILL OF MATERIAL  
 (LEFT LANE WIDENING)

REVISIONS						SHEET NO. S-28
NO.	BY:	DATE:	NO.	BY:	DATE:	
1			3			TOTAL SHEETS 78
2			4			