

NOTES

STIRRUPS IN CAP MAY BE SHIFTED AS NECESSARY TO CLEAR ANCHOR BOLTS.

HOOKS ON "V" BARS MAY BE TURNED AS NECESSARY FOR PLACING REINFORCING STEEL.

FOR PILE SPLICE DETAILS, SEE END BENT 1, SHEET 2 OF 2.

FOR EPOXY PROTECTIVE COATING, SEE SPECIAL PROVISIONS.

THE TOP SURFACE AREAS OF THE BENT CAPS SHALL BE CURED IN ACCORDANCE WITH THE STANDARD SPECIFICATIONS EXCEPT THE MEMBRANE CURING COMPOUND METHOD SHALL NOT BE USED.

THE ROW OF PILES CLOSEST TO EXISTING FOOTING SHALL BE BATTERED TO AVOID INTERFERENCE WITH EXISTING PILES. FOR LOCATION AND DIRECTION OF BATTERING, SEE SHEET 2 OF 2 OR FOUNDATION LAYOUT SHEET.

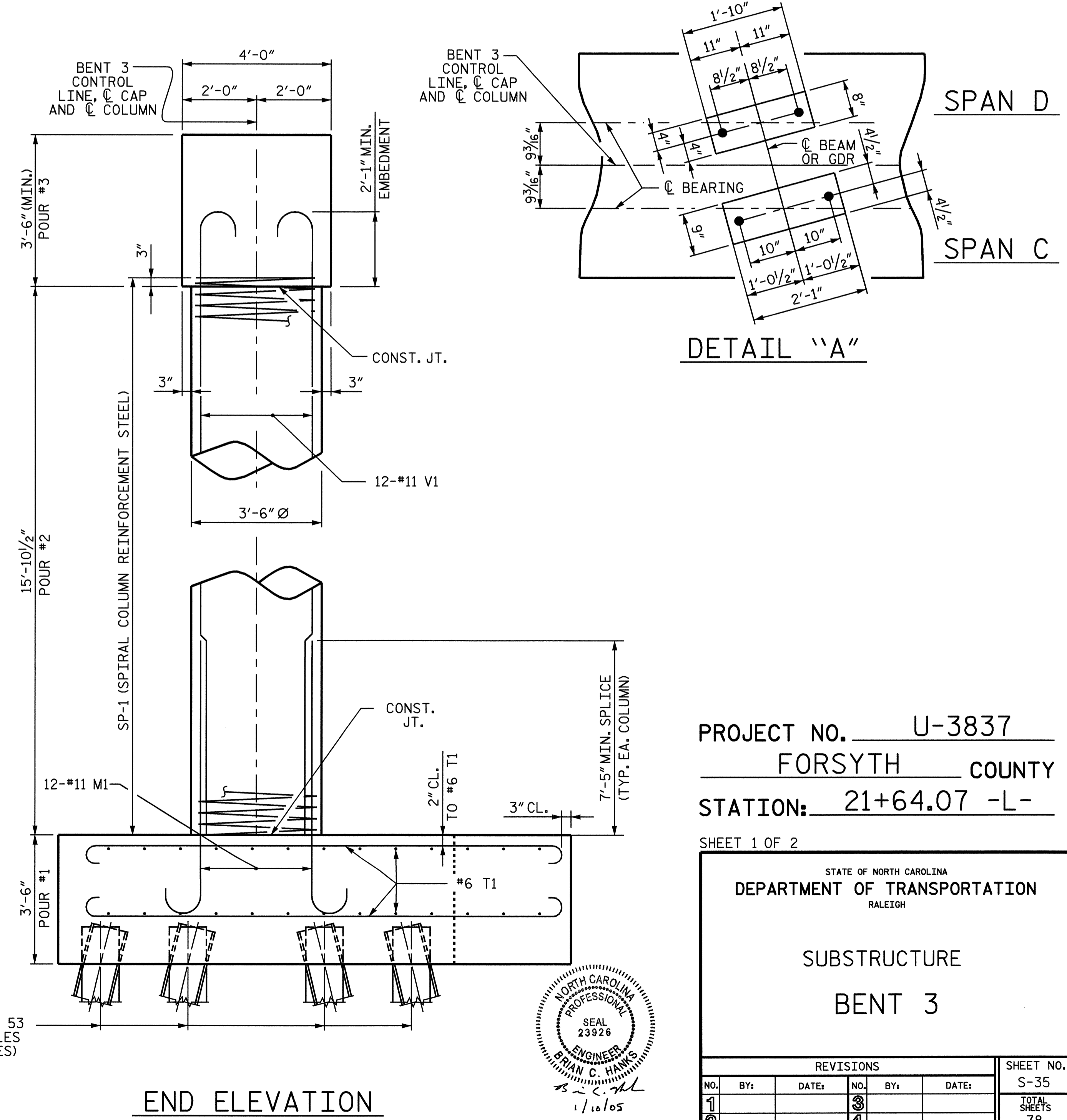
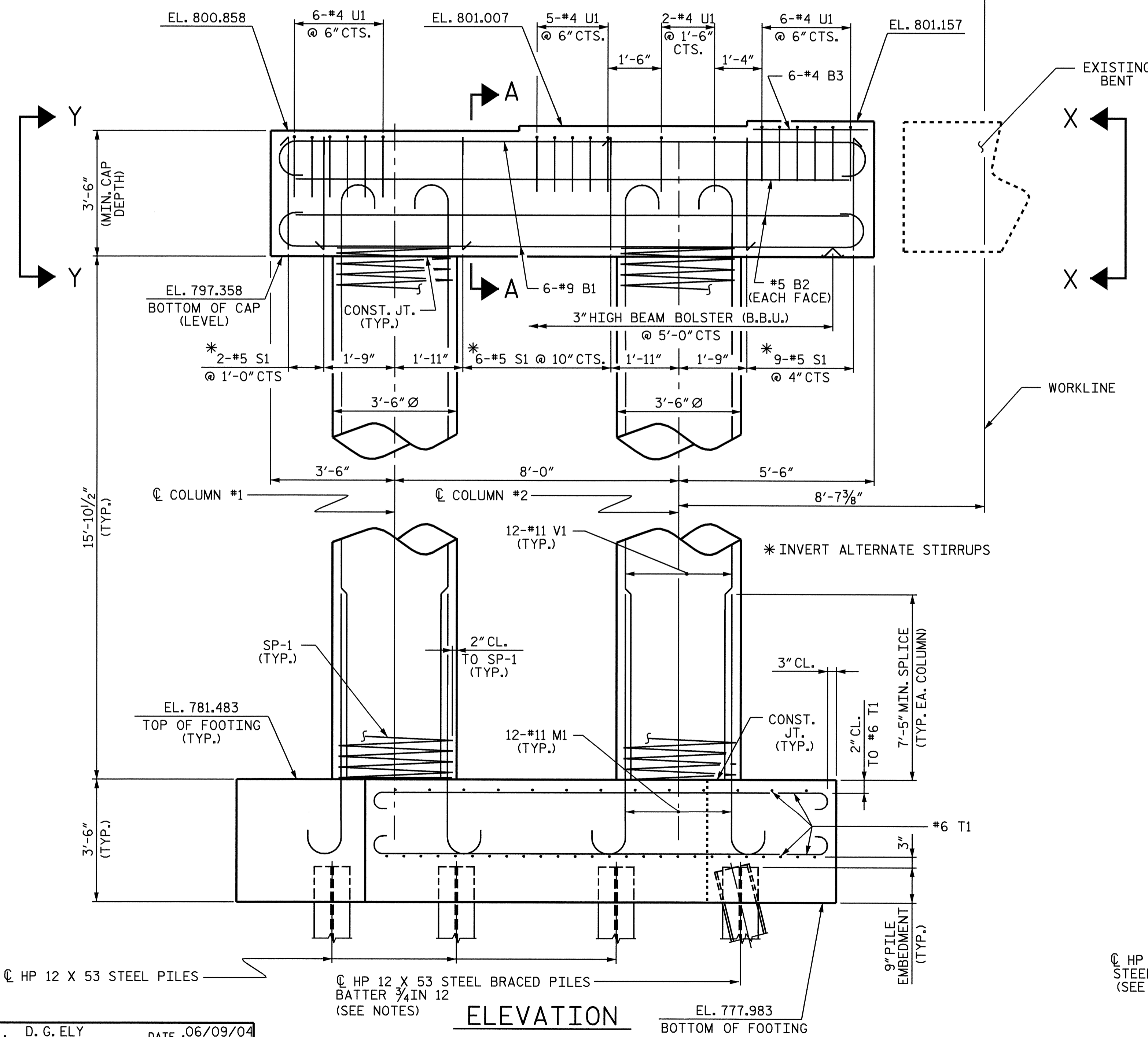
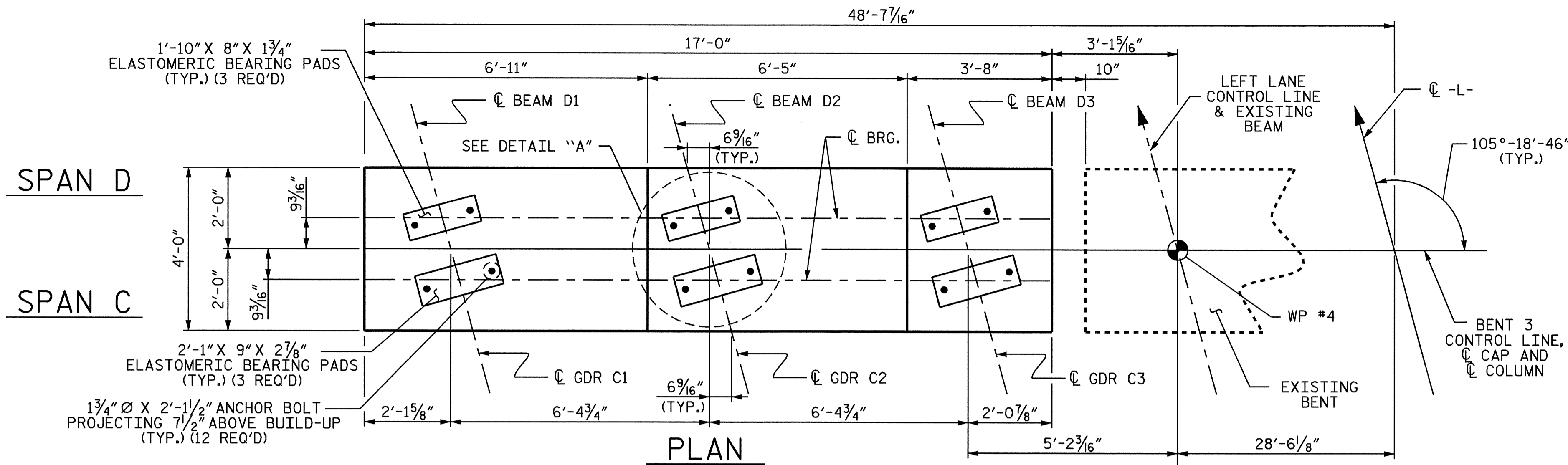

PROJECT NO. U-3837

FORSYTH COUNTY

STATION: 21+64.07 -L-

SHEET 1 OF 2

STATE OF NORTH CAROLINA
DEPARTMENT OF TRANSPORTATION
RALEIGH

SUBSTRUCTURE
BENT 3

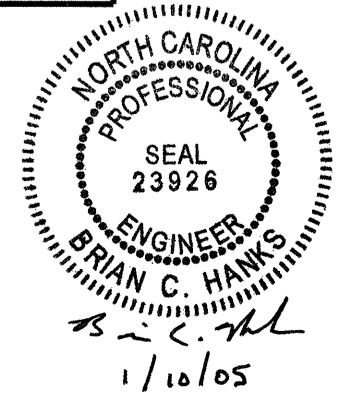

DRAWN BY : D. G. ELY DATE : 06/09/04

CHECKED BY : W. F. PARKER DATE : 07/14/04

REVISIONS						SHEET NO.	
NO.	BY:	DATE:	NO.	BY:	DATE:	S-35	
1			3			TOTAL SHEETS	
2			4			78	