

HALF-SECTION AT INTERMEDIATE DIAPHRAGMS  
 HALF-SECTION AT 12" Ø VOIDS  
**TYPICAL SECTION**

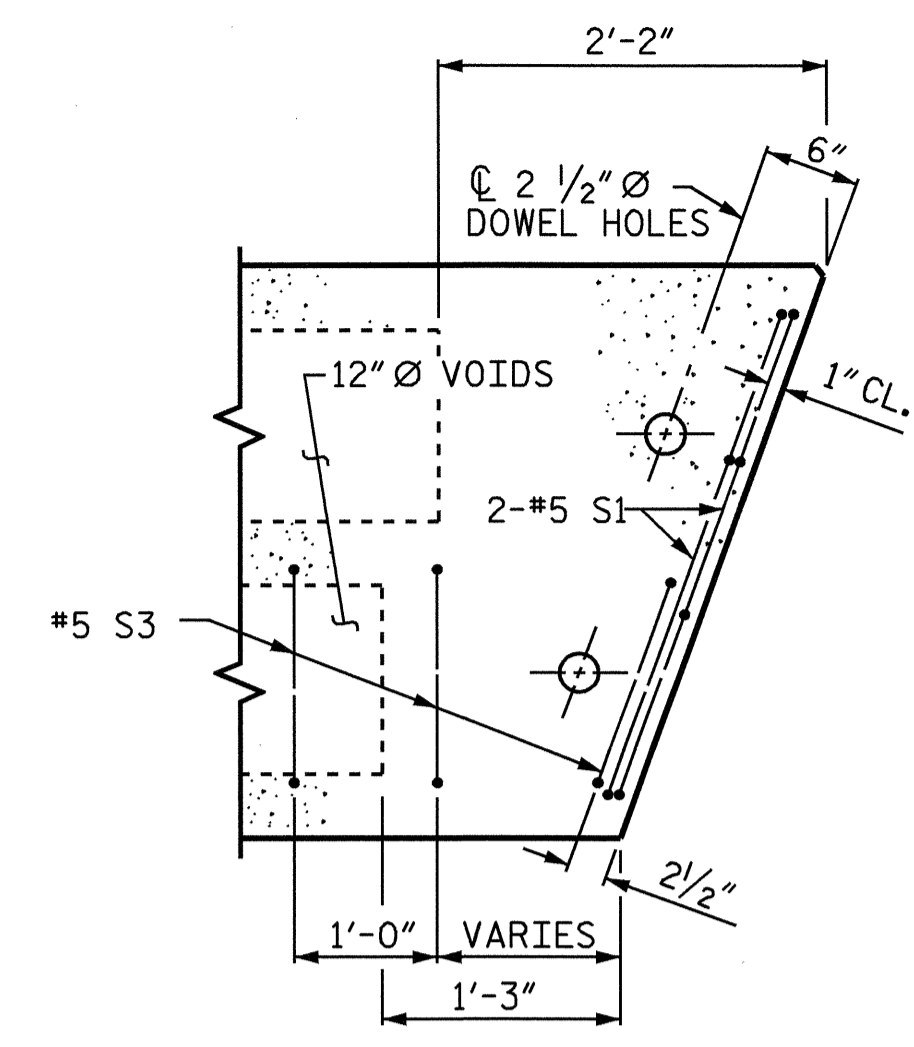

**PART PLAN-EXTERIOR SECTION**  
 NOTE: EXTERIOR SECTION SHOWN-INTERIOR SECTION SIMILAR EXCEPT OMIT S3 BARS.  
 SEE PLAN OF CORED SLAB UNITS SHEETS FOR DIM. TO #5 S3

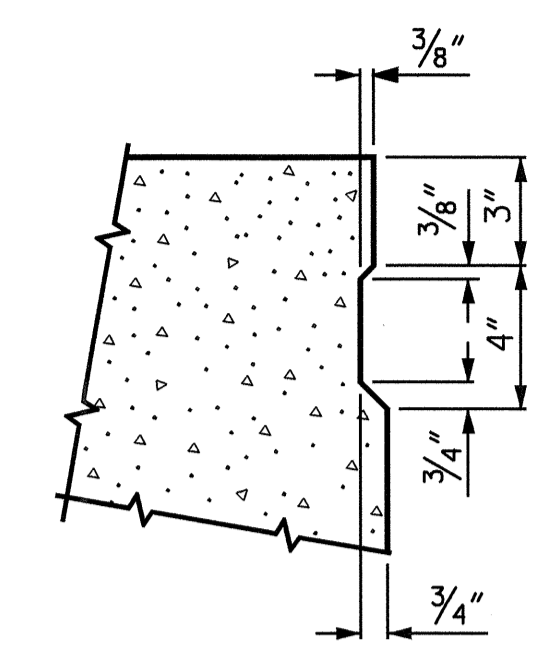

**SHEAR KEY DETAIL**  
 NOTE: OMIT SHEAR KEY ON OUTSIDE FACE OF EXTERIOR CORED SLABS.

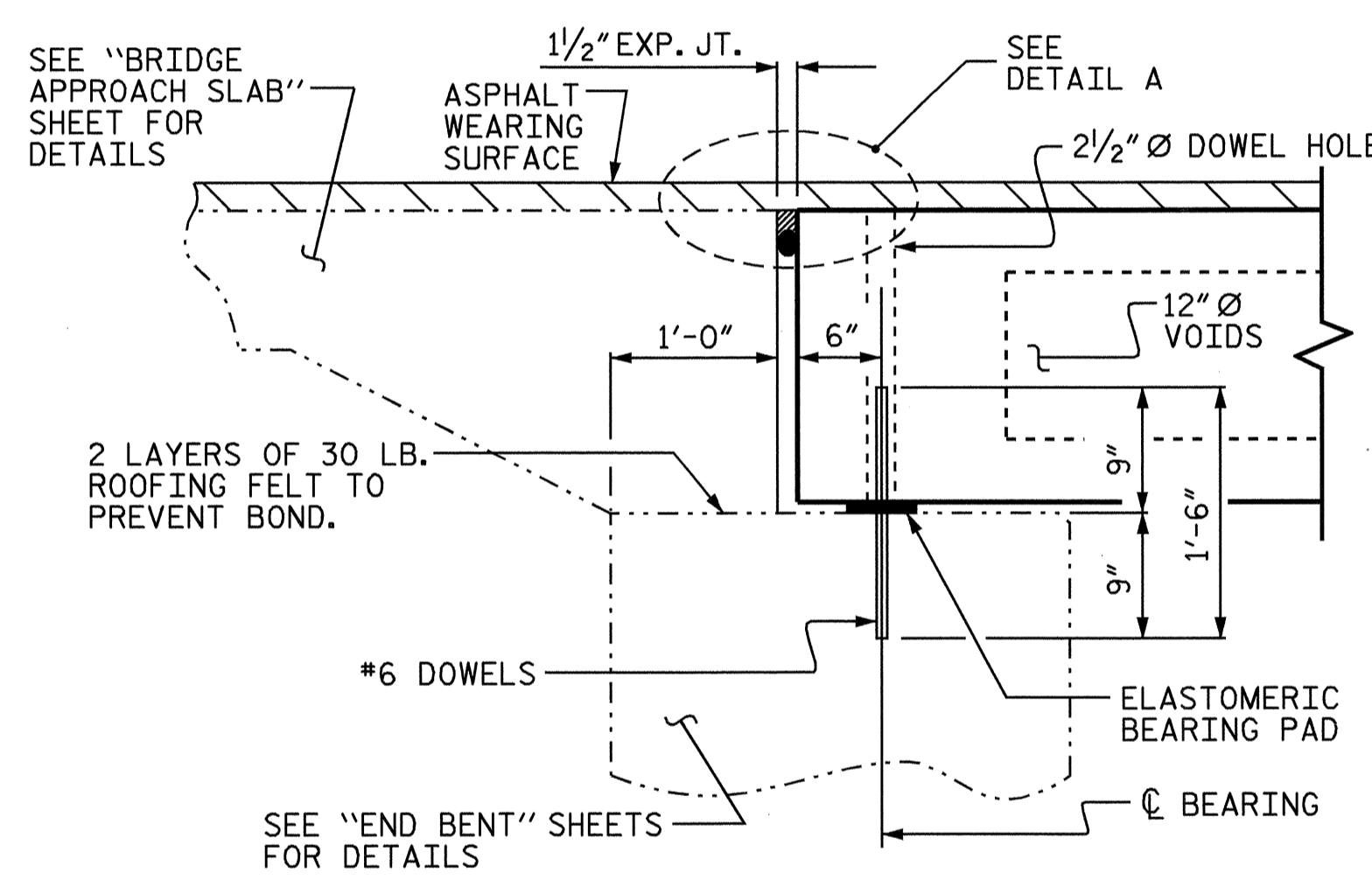

**SECTION AT END BENT**

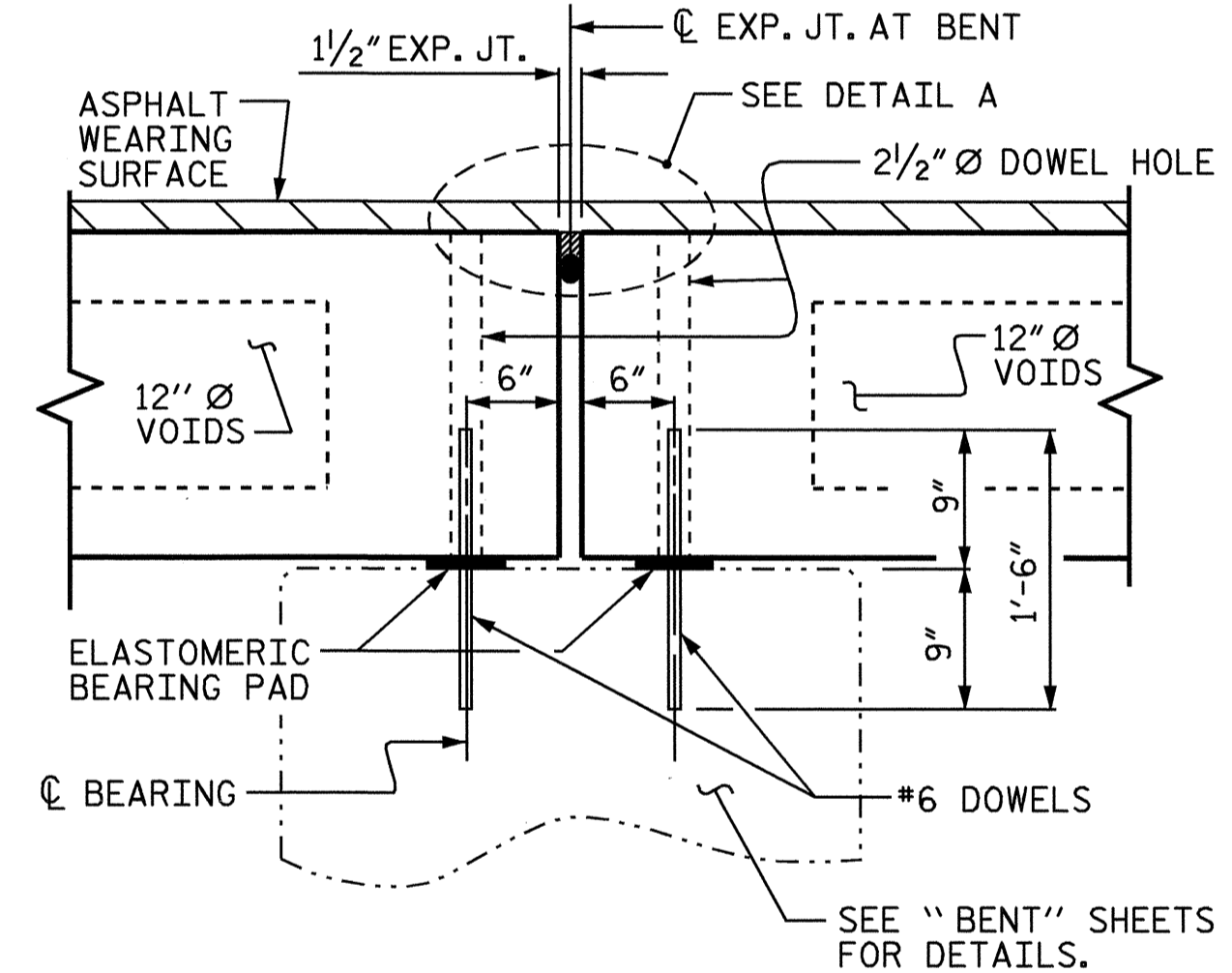

**SECTION AT BENT**

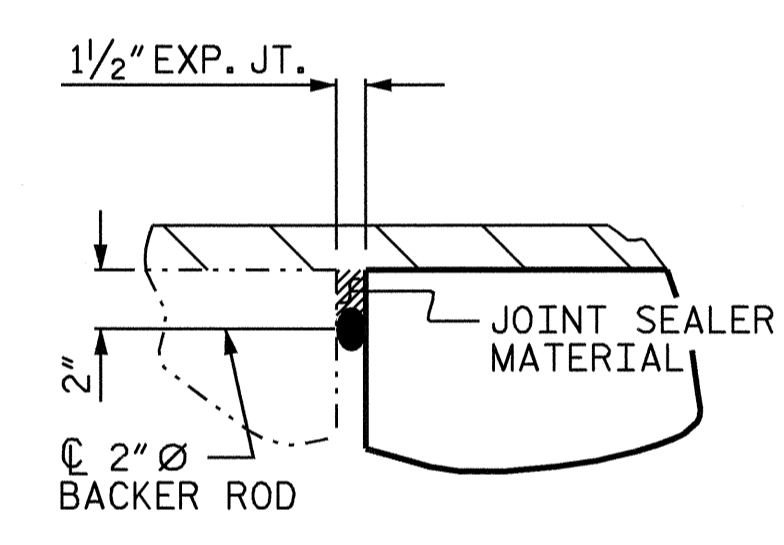

**DETAIL A**

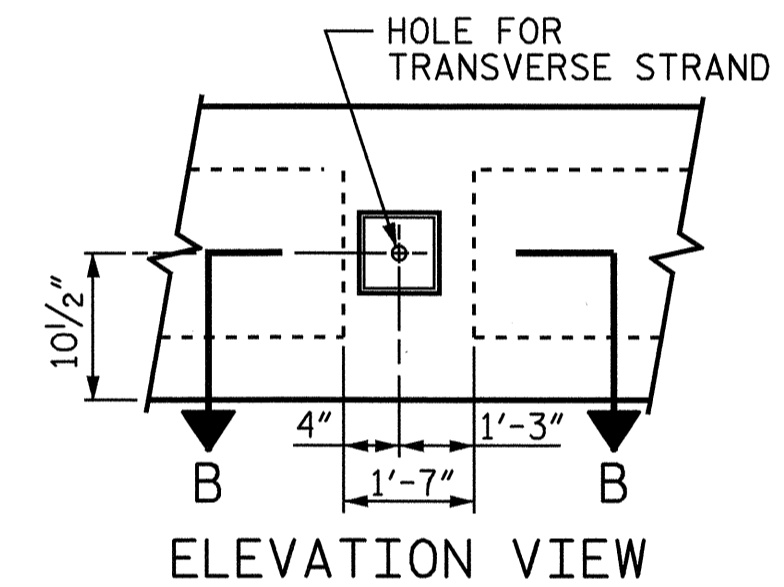

**ELEVATION VIEW**

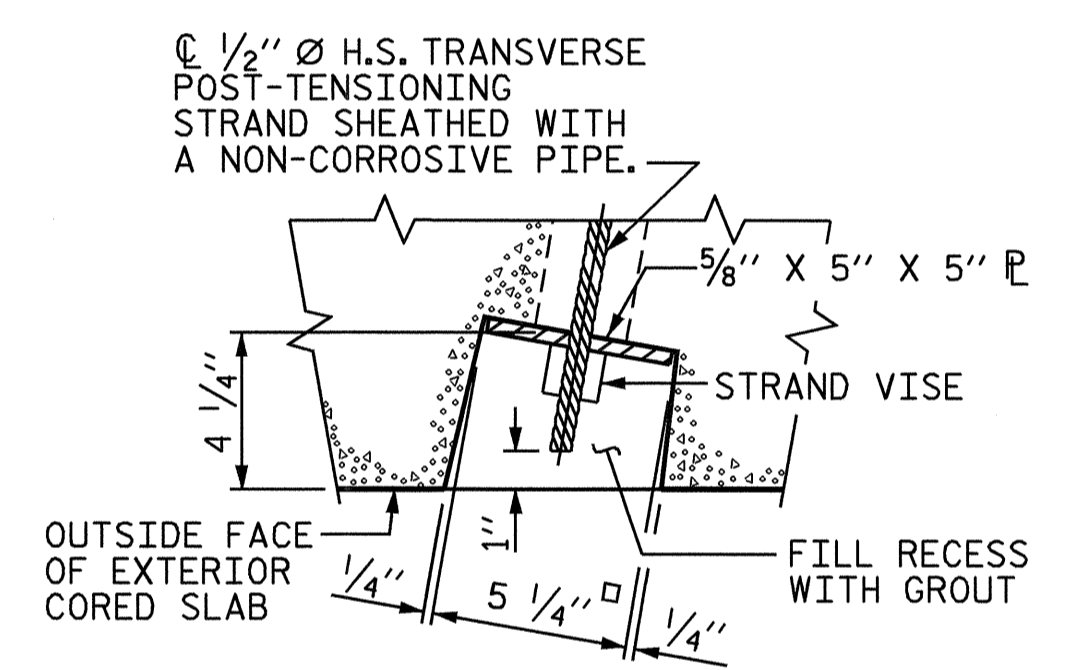

**SECTION B-B**

**GROUTED RECESS AT END OF POST-TENSIONED STRAND-CORED SLAB**

■ BOND SHALL BE BROKEN ON THESE STRANDS FOR A DISTANCE OF 4'-0" FROM END OF CORED SLAB UNIT FOR SPANS "A" AND "C" AND 4'-4" FOR SPAN "B." SEE STANDARD SPECIFICATIONS ARTICLE 1078-7.

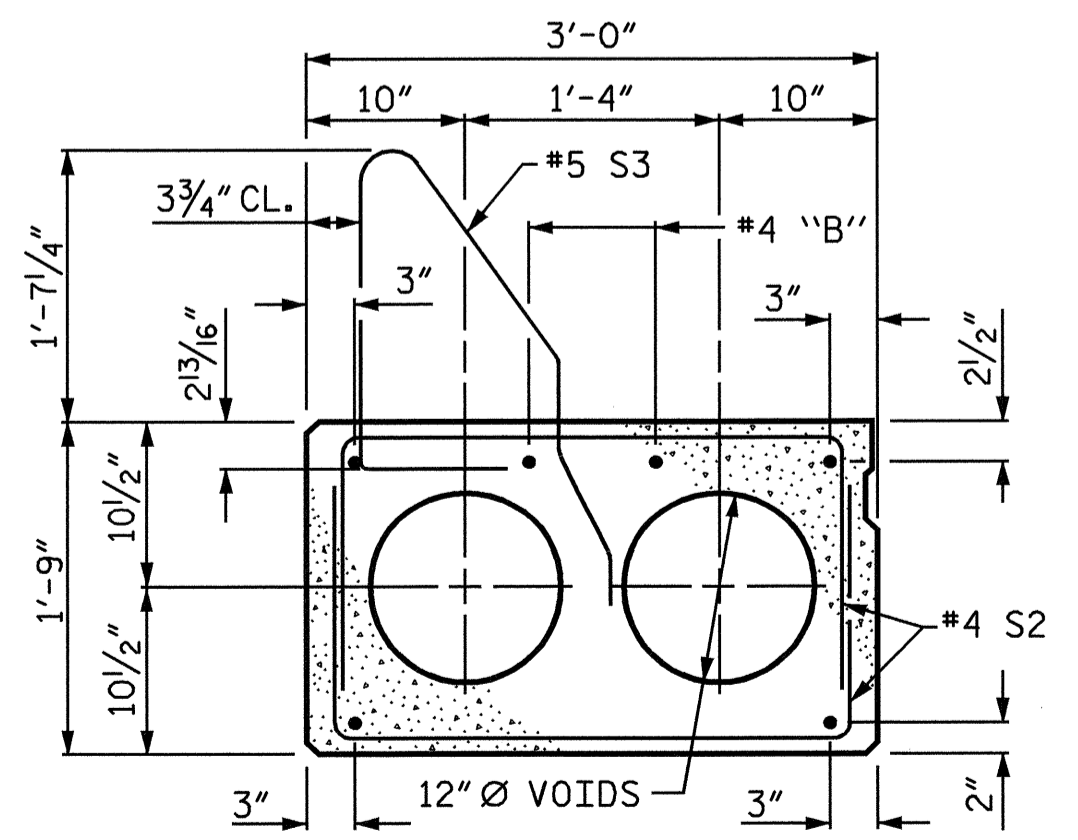

**EXTERIOR SLAB SECTION**  
 (FOR PRESTRESSED STRAND LAYOUT, SEE INTERIOR SLAB SECTION.)

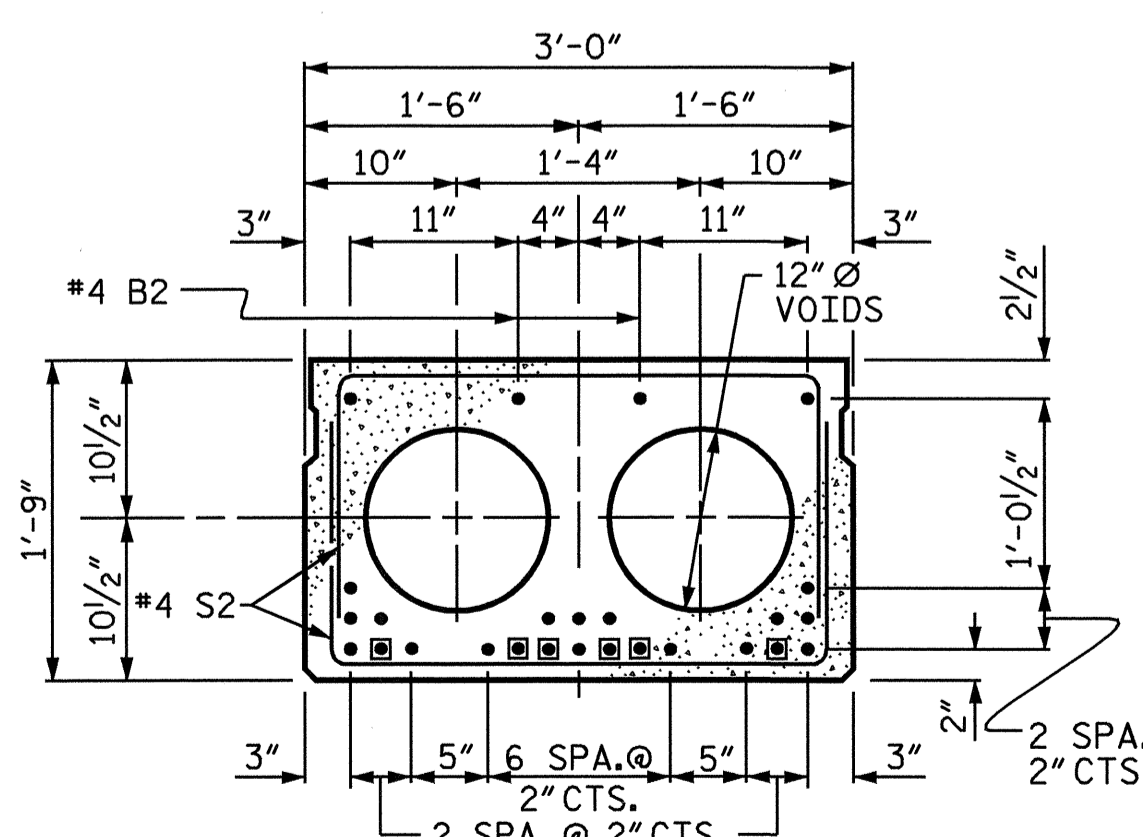

**INTERIOR SLAB SECTION**  
**1/2" Ø LOW RELAXATION STRAND LAYOUT**  
 TYPICAL SPAN "B" ONLY (24 STRANDS)

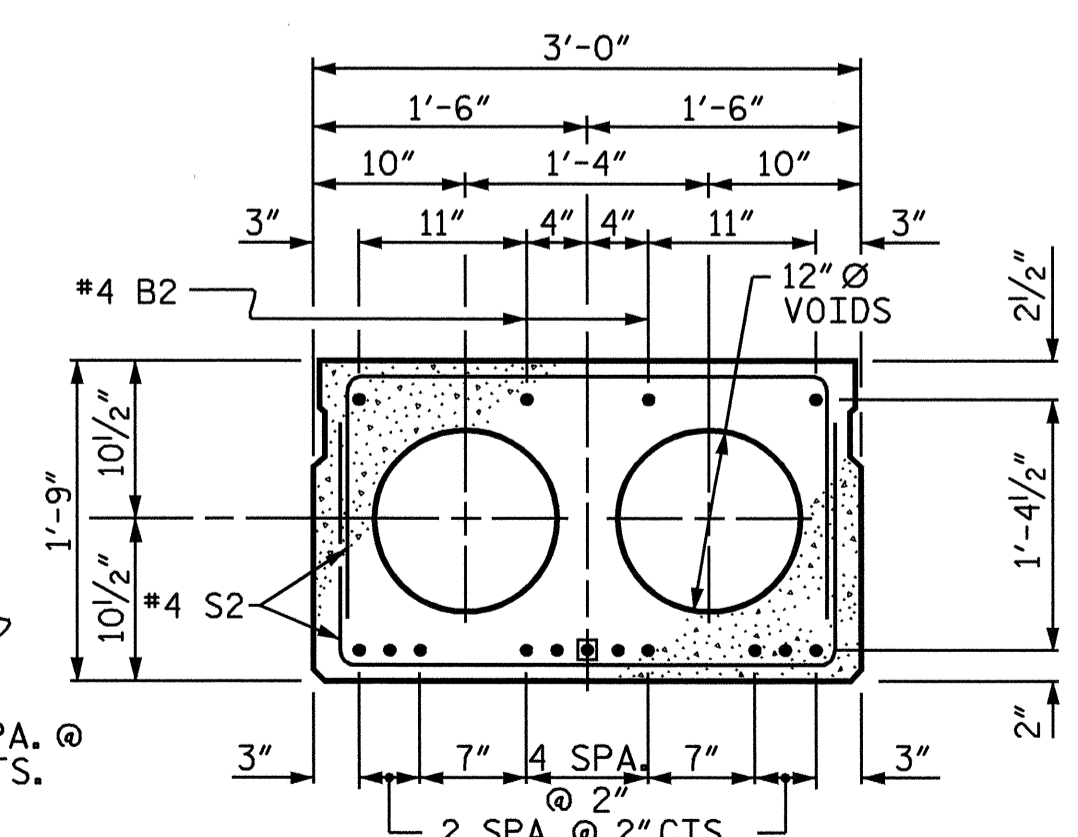

**INTERIOR SLAB SECTION**  
**1/2" Ø LOW RELAXATION STRAND LAYOUT**  
 TYPICAL SPANS "A" & "C" (13 STRANDS)

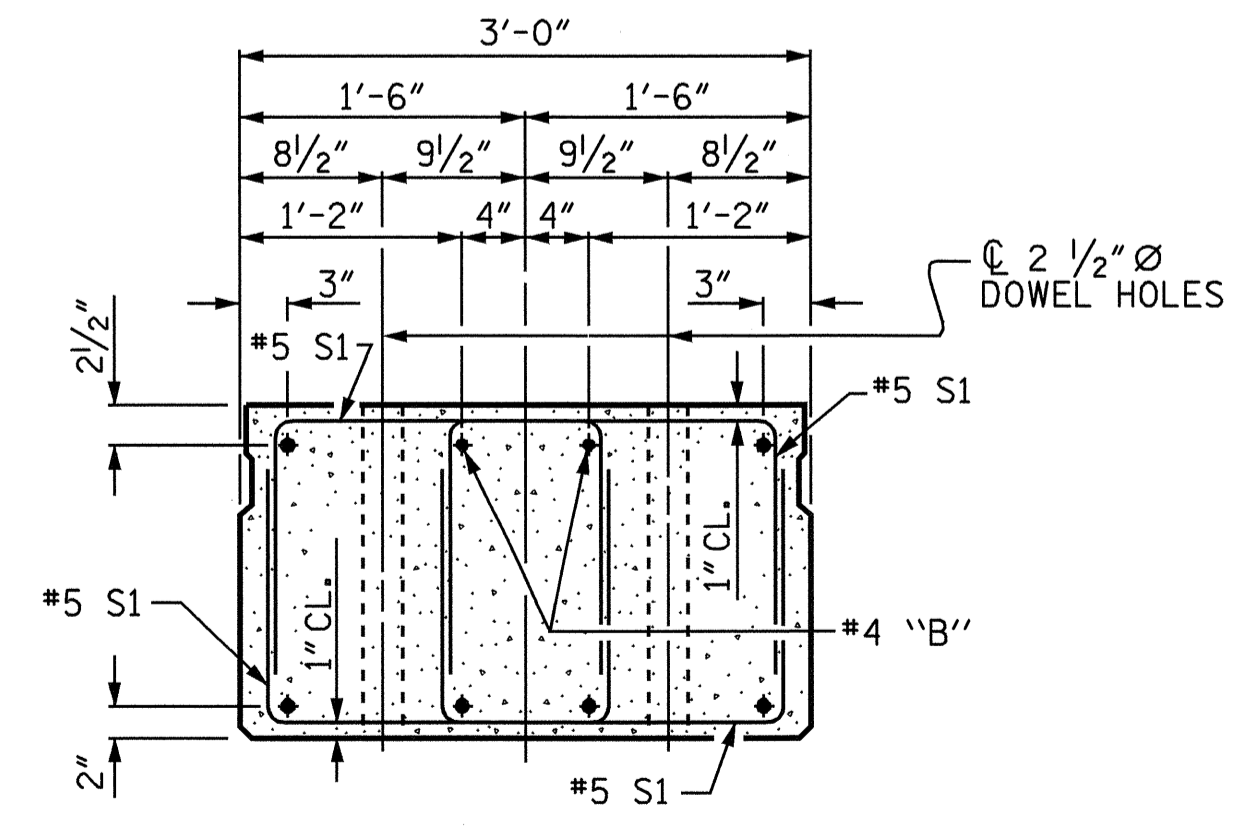

**END ELEVATION**

SHOWING PLACEMENT OF DOUBLE STIRRUPS AND LOCATION OF DOWEL HOLES. STRAND LAYOUT NOT SHOWN. INTERIOR SLAB SECTION SHOWN-EXTERIOR SLAB SECTION SIMILAR EXCEPT SHEAR KEY LOCATION.

PROJECT NO. B-3899  
ROCKINGHAM COUNTY  
 STATION: 23+91.00 -L-

SHEET 1 OF 7

STATE OF NORTH CAROLINA  
 DEPARTMENT OF TRANSPORTATION  
 RALEIGH  
**3'-0" X 1'-9"**  
**PRESTRESSED CONCRETE CORED SLAB UNIT**

REVISIONS				SHEET NO.	
NO.	BY	DATE	NO.	BY	DATE
1			3		
2			4		

S-4  
TOTAL SHEETS  
24

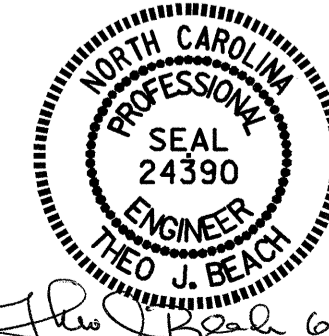

DRAWN BY: P.C. BREWER DATE: 4/23/04  
 CHECKED BY: S.B. WILLIAMS DATE: 5/3/04