

PLAN

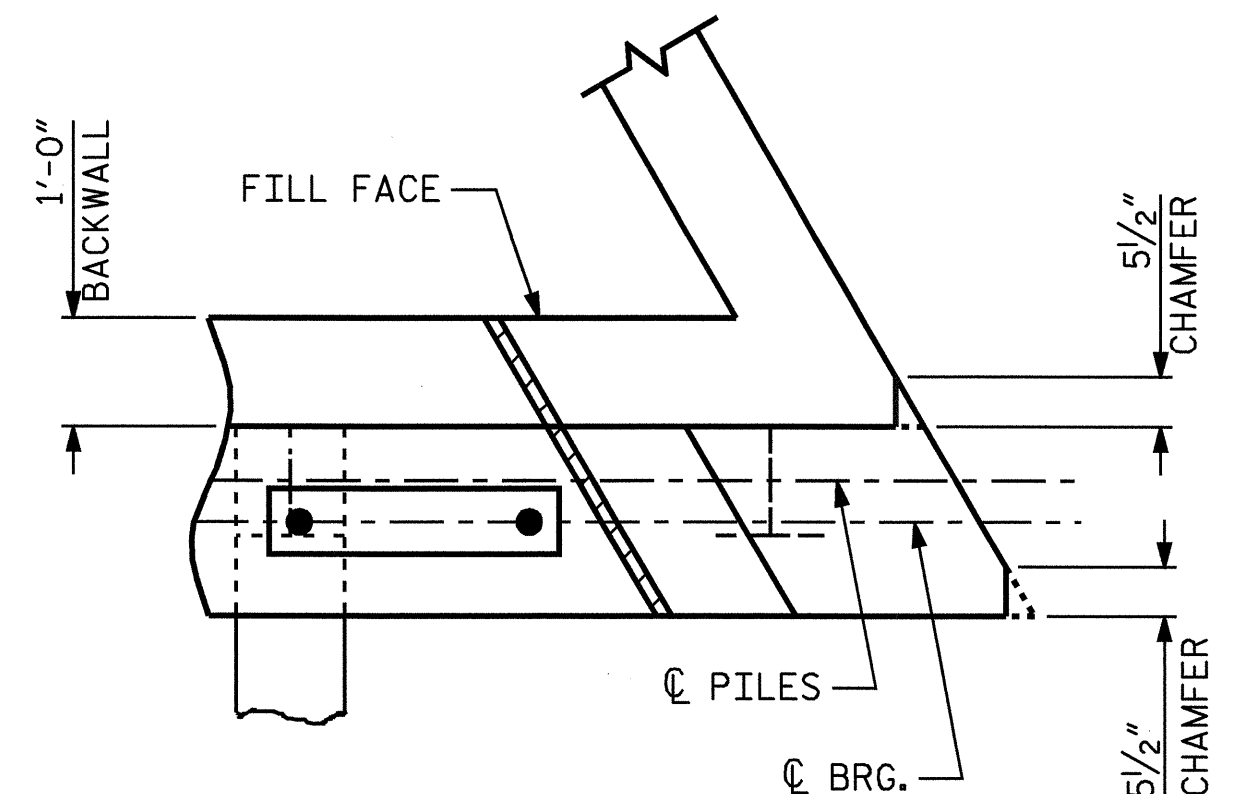

CHAMFERING ACUTE END BENT CORNER

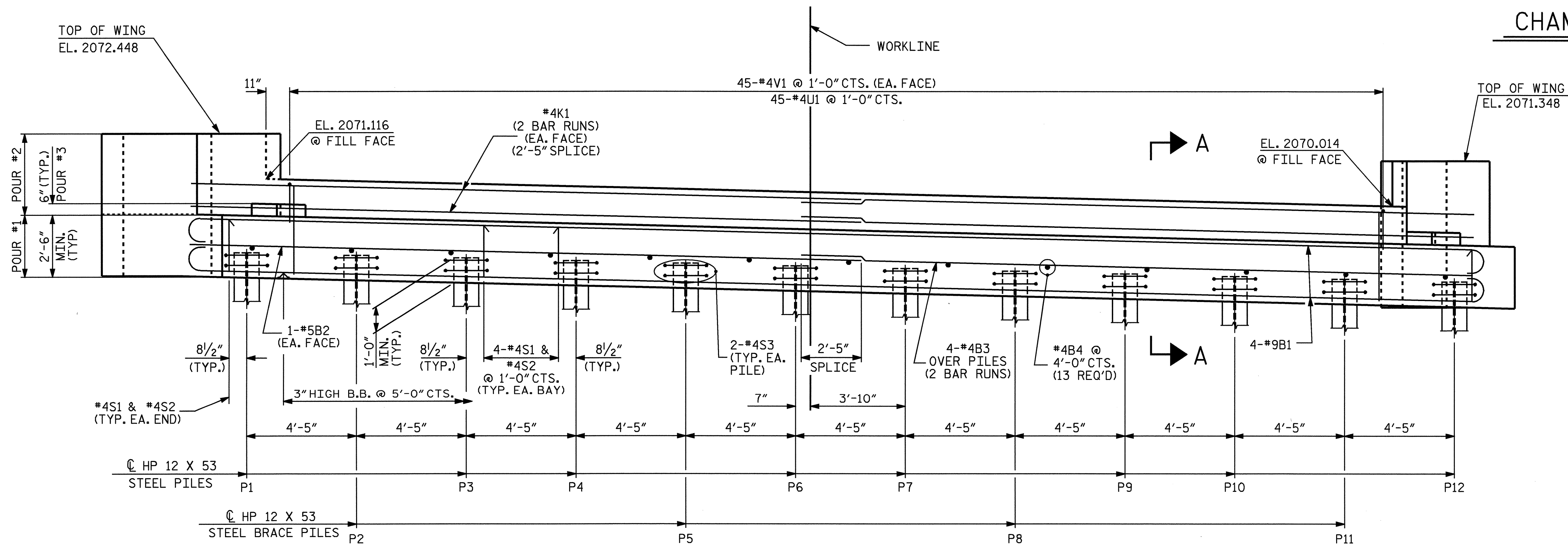

ELEVATION

TOP OF PILE ELEVATION CHART												
P1	P2	P3	P4	P5	P6	P7	P8	P9	P10	P11	P12	
2067.602	2067.495	2067.388	2067.280	2067.173	2067.066	2066.958	2066.851	2066.744	2066.636	2066.529	2066.422	

NOTES

- STIRRUPS IN CAP MAY BE SHIFTED AS NECESSARY TO CLEAR DOWELS.
- FOR EPOXY PROTECTIVE COATING, SEE SPECIAL PROVISIONS.
- FOR PILE SPLICE DETAILS, SEE SHEET 3 OF 3.
- THE CONTRACTOR SHALL PROVIDE FOR INSTALLATION OF THE 4" DIAMETER DRAIN PIPE THROUGH THE WING WALL AS REQUIRED FOR REINFORCED BRIDGE APPROACH FILLS, SEE THE ROADWAY PLANS. REINFORCING STEEL IN THE WING WALL MAY BE SHIFTED AS NECESSARY TO CLEAR THE DRAIN PIPE.
- FOR SECTION A-A, SEE SHEET 3 OF 3.
- THE LATERAL GUIDE AT EACH END OF THE CAP IS NOT TO BE POURED UNTIL AFTER THE CORED SLAB UNITS ARE IN PLACE.

DRAWN BY : L.L. MURPHY DATE : 04-05
 CHECKED BY : D. HODGE DATE : 05-05

03-JUN-2005 14:24
 R:\STRUCT\B3664\lmurphy\MICROS\B3664.L.DGN
 lmurphy



PROJECT NO. B-3664
 HENDERSON COUNTY
 STATION: 20+95.00-L-

SHEET 1 OF 3

STATE OF NORTH CAROLINA
 DEPARTMENT OF TRANSPORTATION
 RALEIGH

SUBSTRUCTURE
 END BENT NO.2

REVISIONS						SHEET NO.
NO.	BY:	DATE:	NO.	BY:	DATE:	S-21
1			3			TOTAL SHEETS 27
2			4			

NCBDS