

NOTES

STIRRUPS IN CAP MAY BE SHIFTED AS NECESSARY TO CLEAR ANCHOR BOLTS.

FOR EPOXY PROTECTIVE COATING, SEE SPECIAL PROVISIONS.

BACKWALL SHALL BE PLACED BEFORE APPLYING THE EPOXY PROTECTIVE COATING.

THE TOP SURFACE AREAS OF THE END BENT CAPS SHALL BE CURED IN ACCORDANCE WITH THE STANDARD SPECIFICATIONS EXCEPT THE MEMBRANE CURING COMPOUND METHOD SHALL NOT BE USED.

THE TOP SURFACE OF THE CAP EXCEPT THE BRIDGE SEAT BUILDUPS SHALL BE SLOPED TRANSVERSELY FROM THE FILL FACE TO THE BACK FACE AT THE RATE OF 2%.

THE CONTRACTOR SHALL PROVIDE FOR INSTALLATION OF THE 4" DIAMETER DRAIN PIPE THROUGH THE WING WALL AS REQUIRED FOR REINFORCED BRIDGE APPROACH FILLS, SEE THE ROADWAY PLANS. REINFORCING STEEL IN THE WING WALL MAY BE SHIFTED AS NECESSARY TO CLEAR THE DRAIN PIPE.

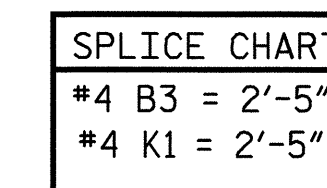
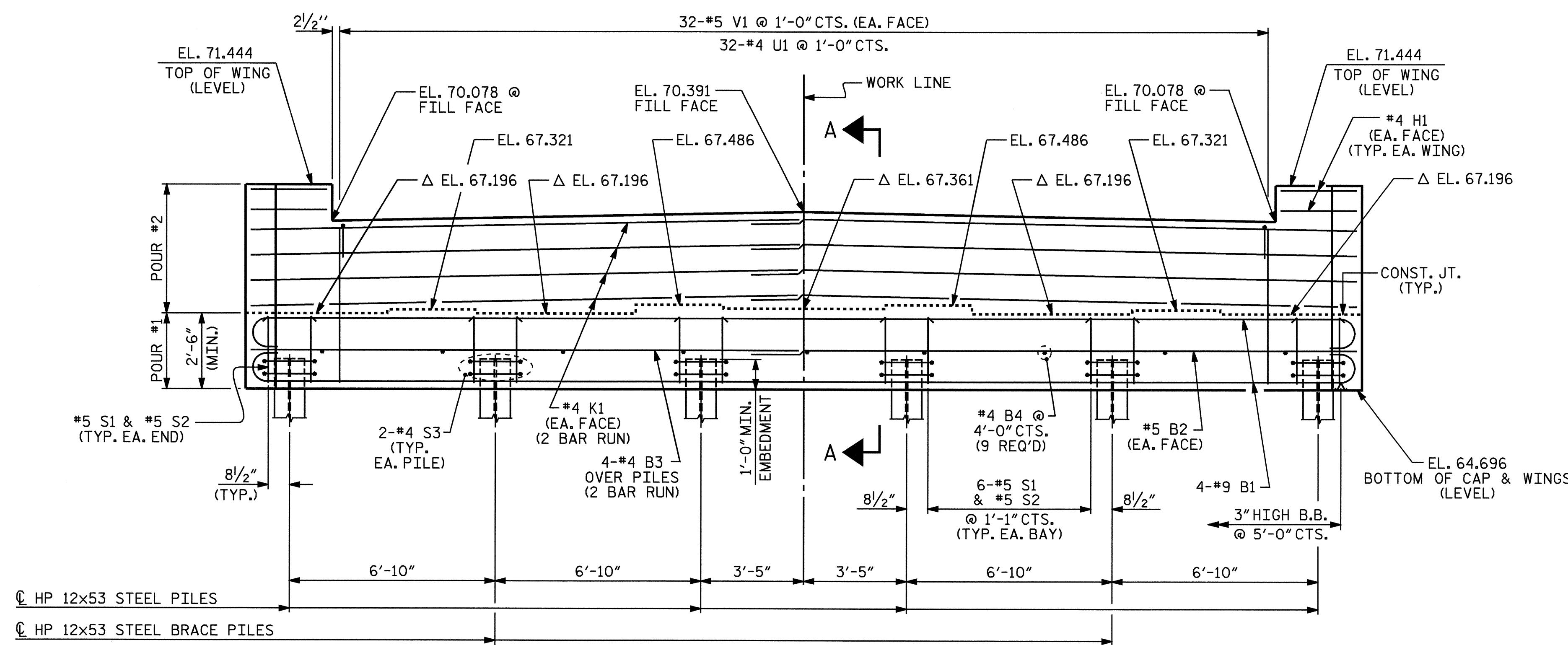
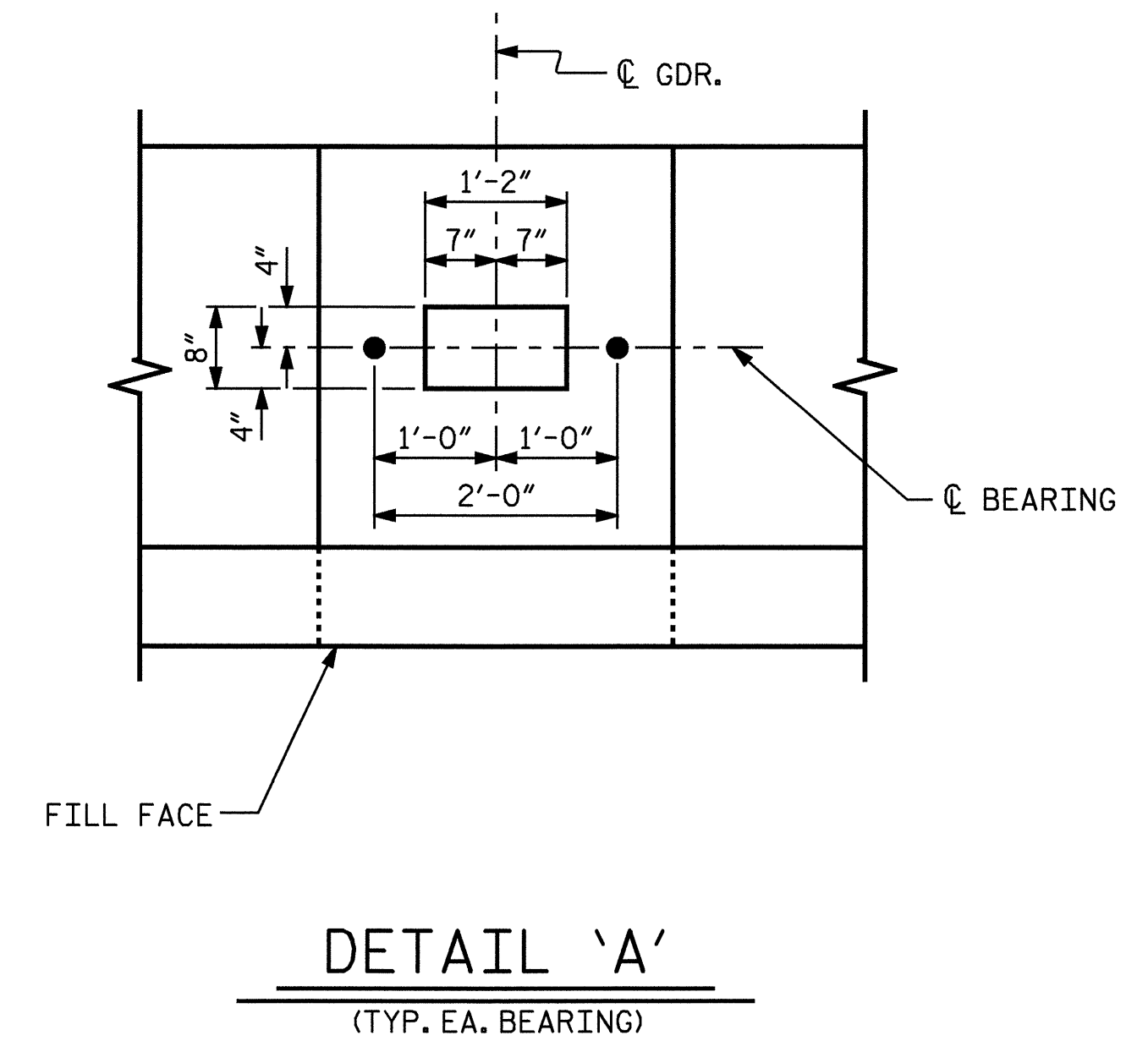
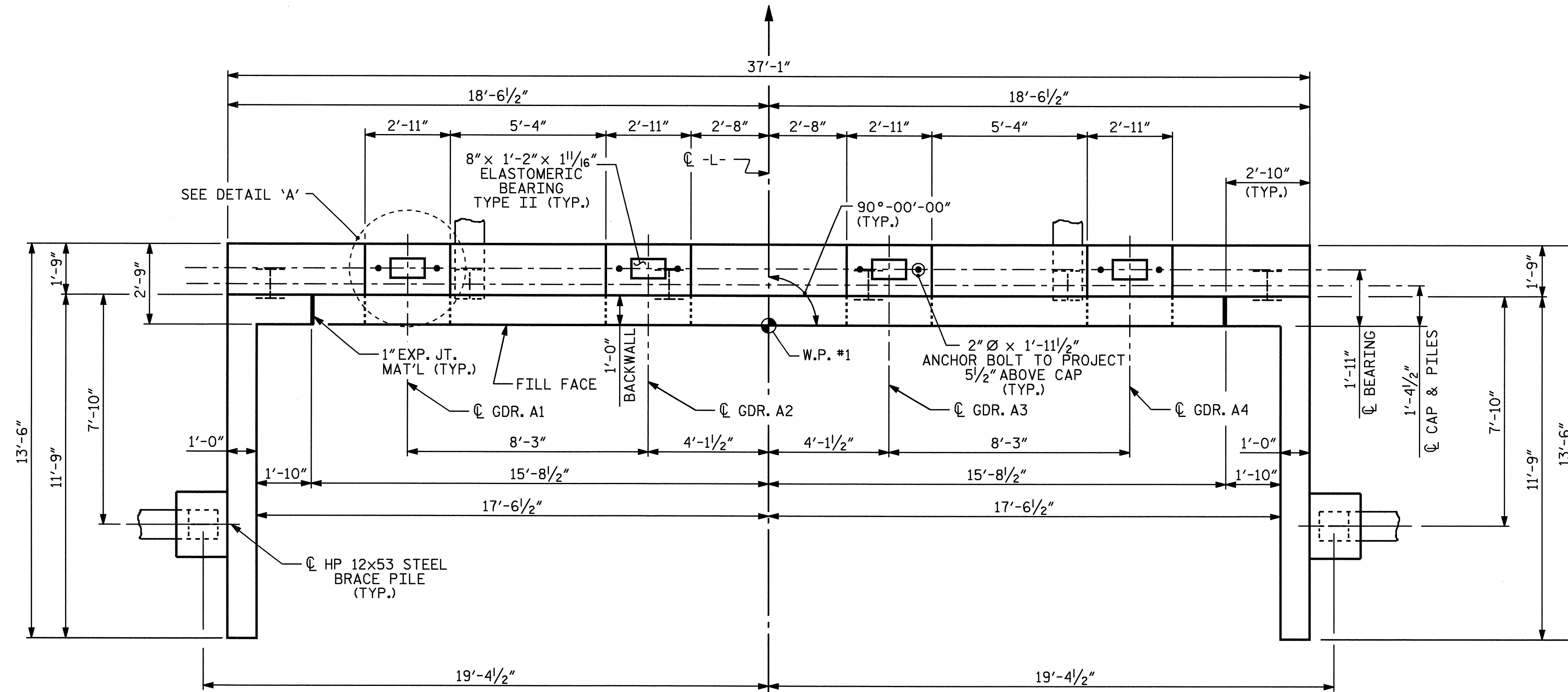

PROJECT NO. B-3467
HALIFAX COUNTY
 STATION: 31+50.00 -L-

SHEET 1 OF 2

STATE OF NORTH CAROLINA DEPARTMENT OF TRANSPORTATION RALEIGH					
SUBSTRUCTURE END BENT 1					
REVISIONS					SHEET NO.
NO.	BY:	DATE:	NO.	BY:	DATE:
1			3		
2			4		
					S-47
					TOTAL SHEETS 60

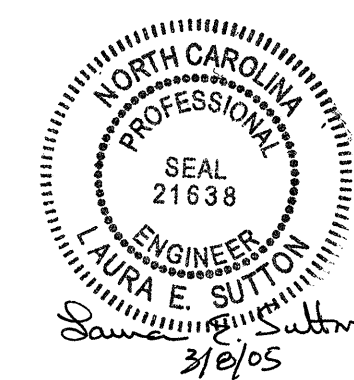

DRAWN BY: J. L. WALTON DATE: 10/13/03
 CHECKED BY: B.N. BARODAWALA DATE: 10/28/03