

**PART PLAN-EXTERIOR SECTION**

NOTE: EXTERIOR SECTION SHOWN-INTERIOR SECTION SIMILAR EXCEPT OMIT S3 BARS.

**HALF SECTION @ POST TENSIONING LOCATIONS**

**HALF SECTION @ END BENT & BENT**

**TYPICAL SECTION**

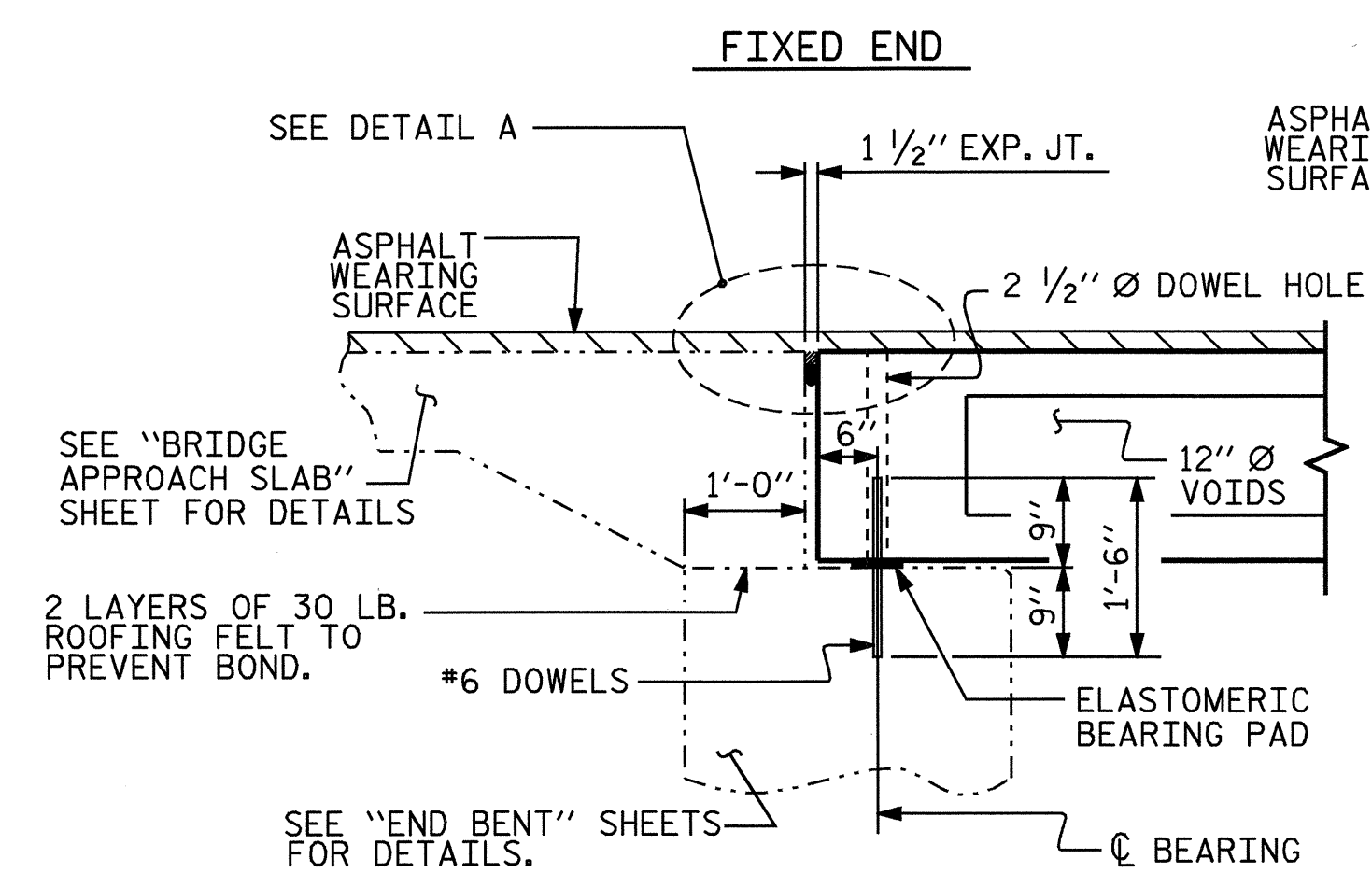

**SECTION AT END BENT**

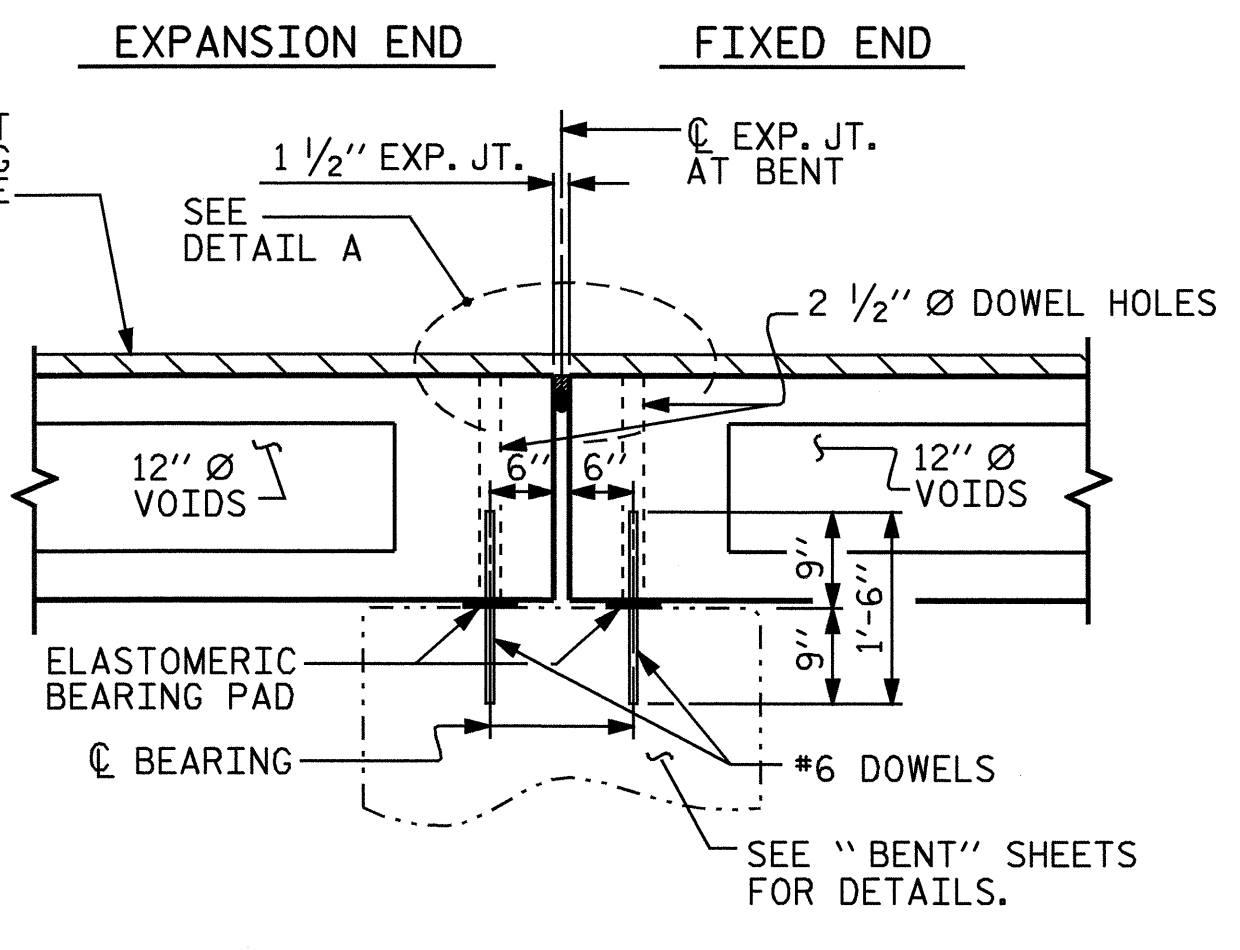

**SECTION AT BENT**

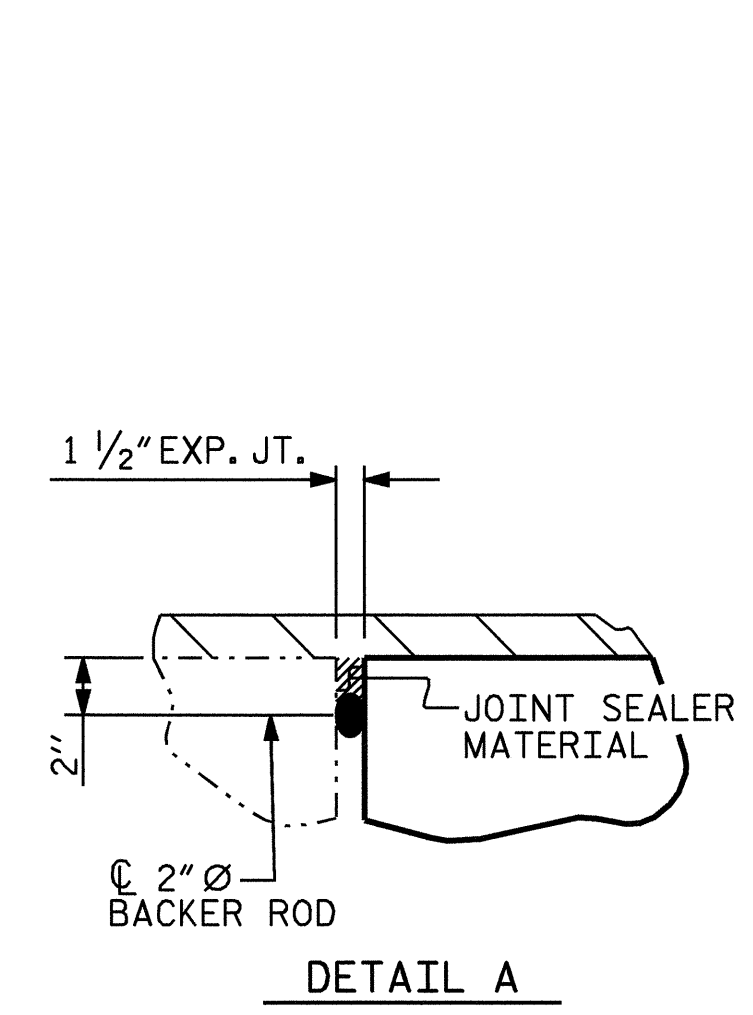

**DETAIL A**

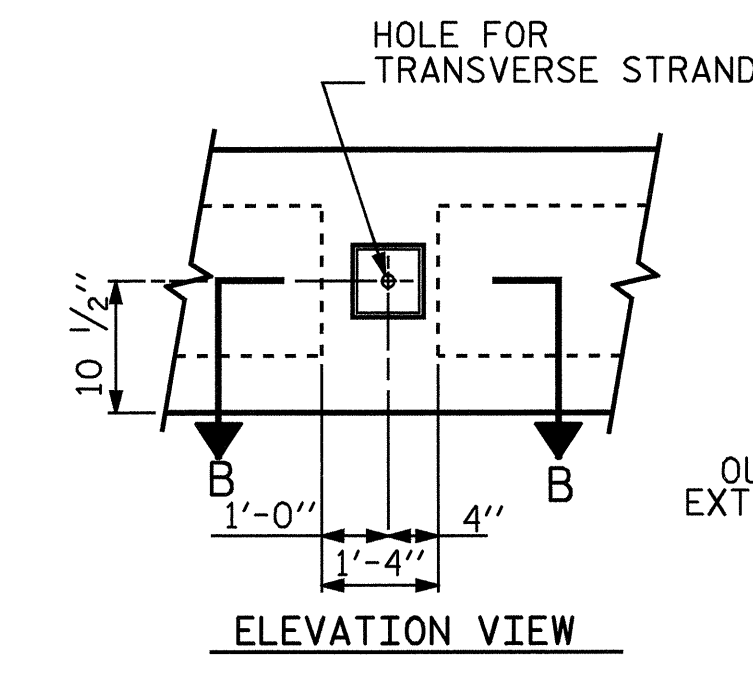

**ELEVATION VIEW**

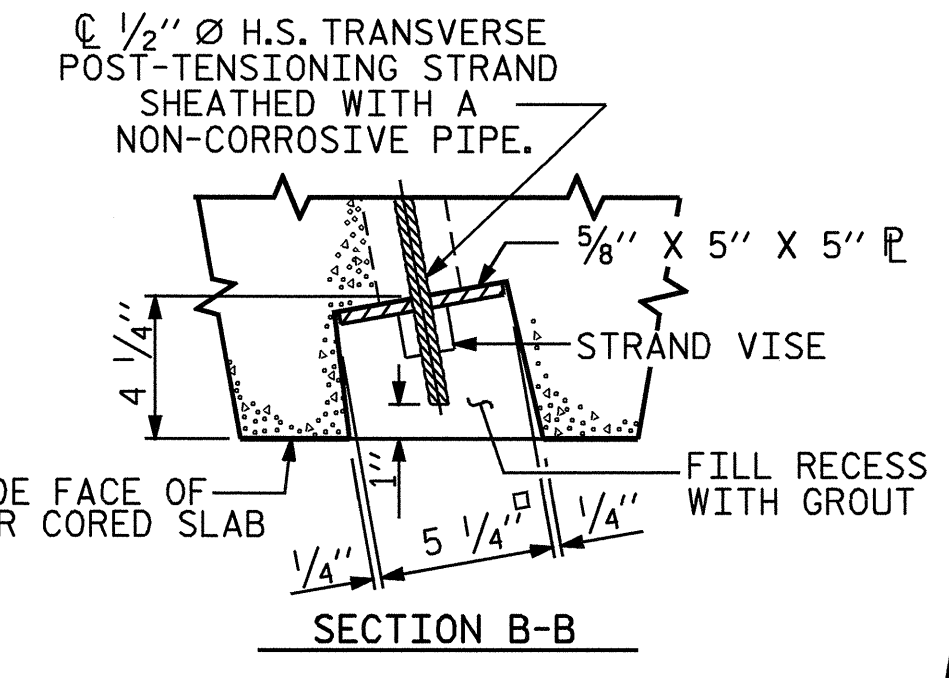

**SECTION B-B**

**GROUTED RECESS AT END OF POST-TENSIONED STRAND CORED SLABS**

■ BOND SHALL BE BROKEN ON THESE STRANDS FOR A DISTANCE OF 4'-0" FROM END OF CORED SLAB UNIT, SEE STANDARD SPECIFICATIONS ARTICLE 1078-7.

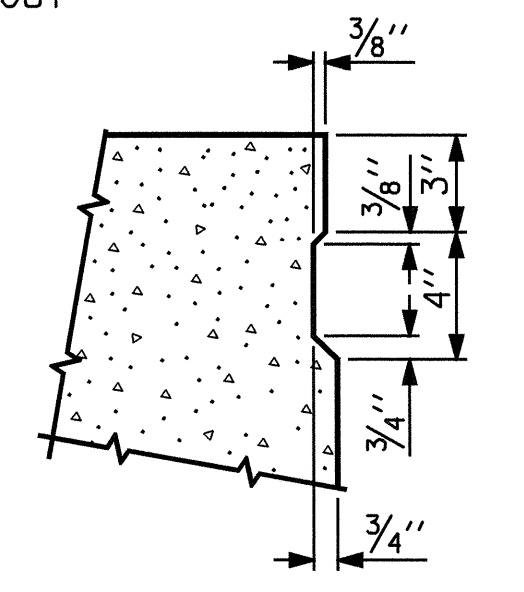

**SHEAR KEY DETAIL**

NOTE: OMIT SHEAR KEY ON OUTSIDE FACE OF EXTERIOR CORED SLABS.

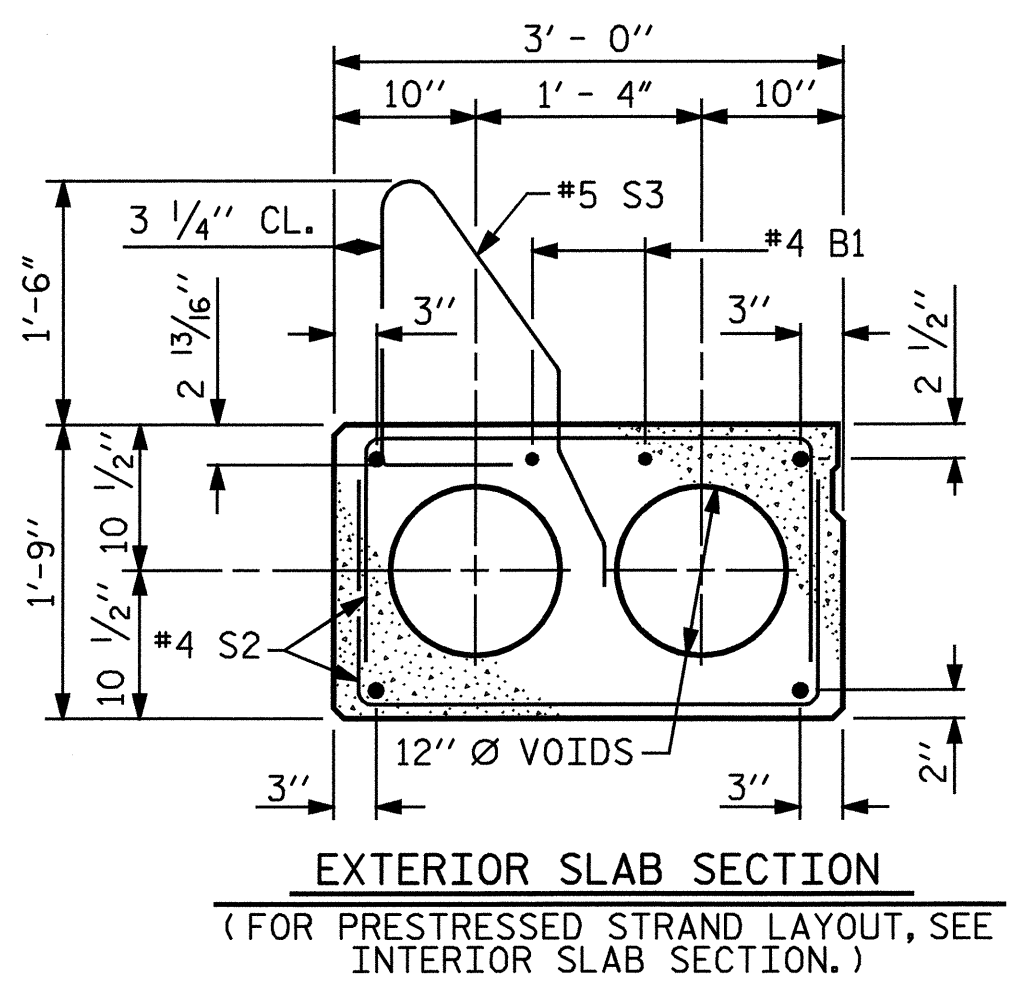

**EXTERIOR SLAB SECTION**

(FOR PRESTRESSED STRAND LAYOUT, SEE INTERIOR SLAB SECTION.)

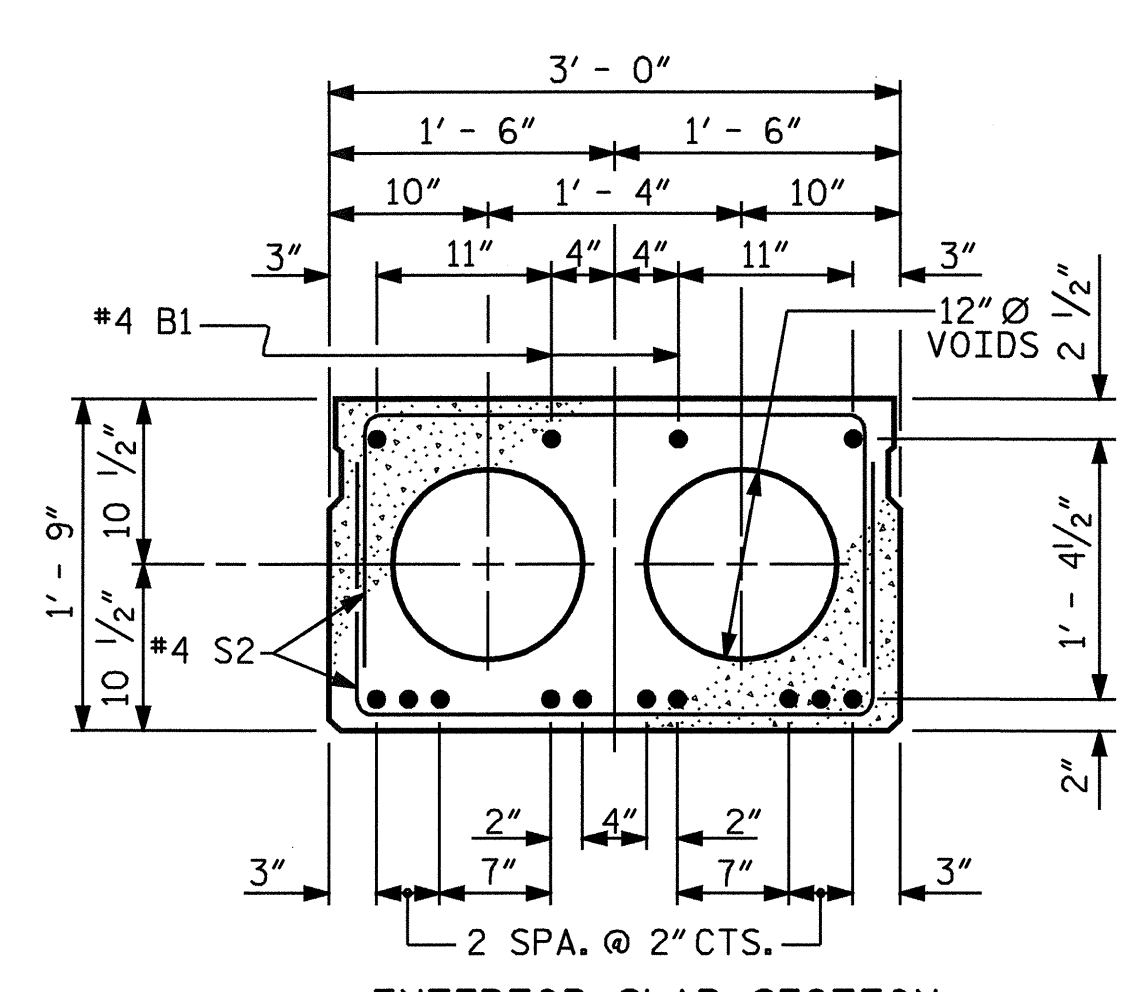

**INTERIOR SLAB SECTION  
1/2" Ø LOW RELAXATION STRAND LAYOUT  
SPAN A & C**

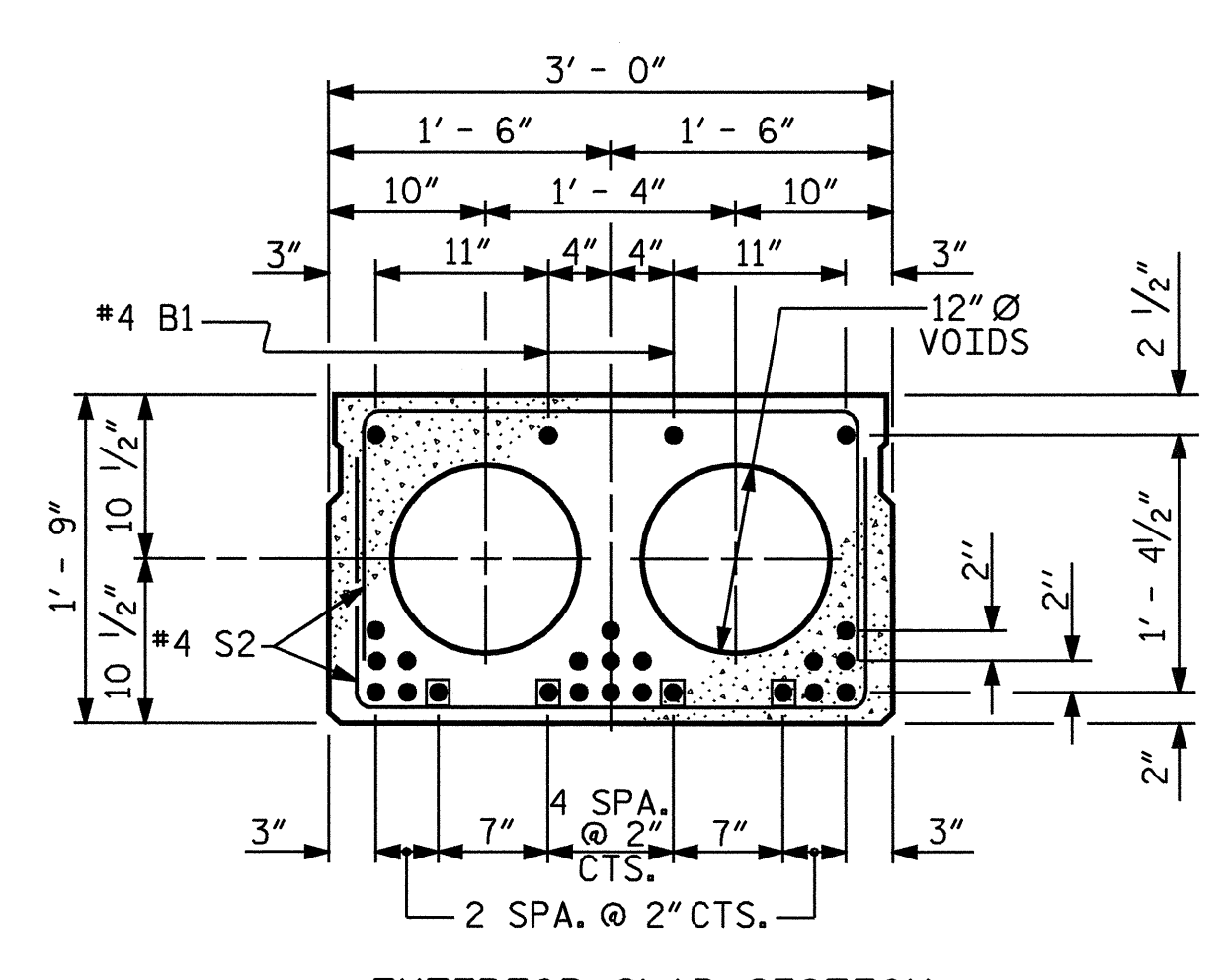

**INTERIOR SLAB SECTION  
1/2" Ø LOW RELAXATION STRAND LAYOUT  
SPAN B**

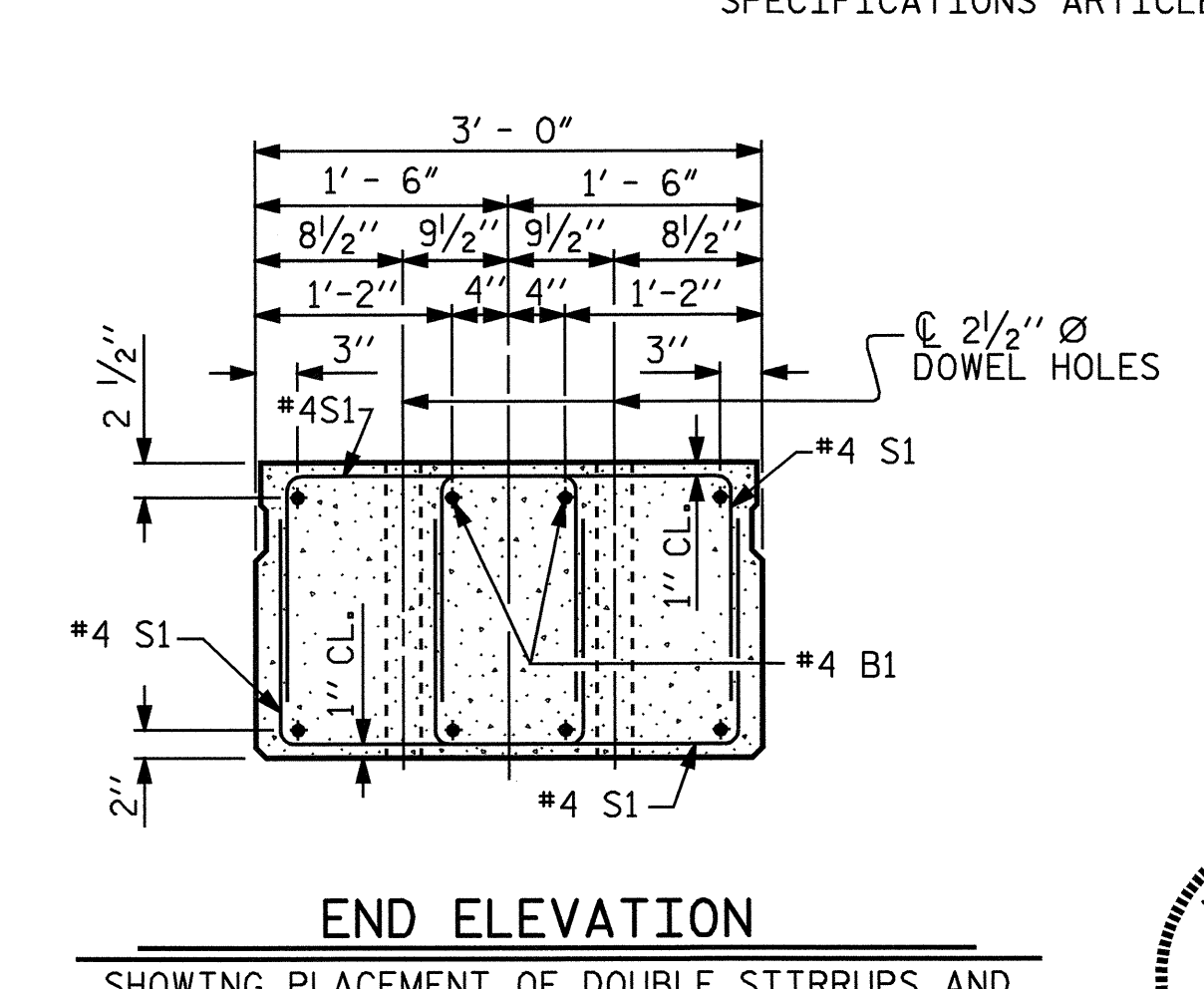

**END ELEVATION**

SHOWING PLACEMENT OF DOUBLE STIRRUPS AND LOCATION OF DOWEL HOLES. (STRAND LAYOUT NOT SHOWN.) INTERIOR SLAB SECTION SHOWN-EXTERIOR SLAB SECTION SIMILAR EXCEPT SHEAR KEY LOCATION.

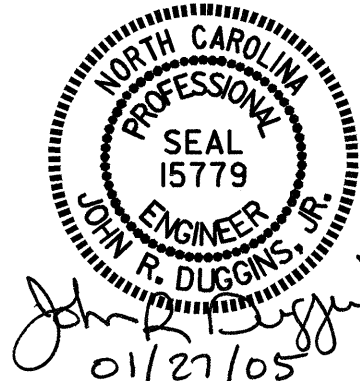

PROJECT NO. B-3887  
 PENDER COUNTY  
 STATION: 15+64.50 -L-

SHEET 1 OF 6  
 STATE OF NORTH CAROLINA  
 DEPARTMENT OF TRANSPORTATION  
 RALEIGH  
 SUPERSTRUCTURE  
 3'-0" X 1'-9"  
 PRESTRESSED CONCRETE  
 CORED SLAB UNIT

REVISIONS						SHEET NO.
NO.	BY:	DATE:	NO.	BY:	DATE:	S-4
1			3			TOTAL SHEETS
2			4			23

ASSEMBLED BY : J. LAMBERT	DATE : 3/2004
CHECKED BY : M. POOLE	DATE : 4/2004
DRAWN BY : WJH 4/89	REV. 2/6/97 EEM/RGW
CHECKED BY : FCJ 5/89	REV. 8/16/99 RWW/LES
	REV. 10/17/00 RWW/LES