

**NOTES**

BARRIER RAIL IN A CONTINUOUS UNIT SHALL NOT BE CAST UNTIL ALL SLAB CONCRETE IN THE UNIT HAS BEEN CAST AND HAS REACHED A MINIMUM COMPRESSIVE STRENGTH OF 3,000 PSI.

THE JOINT IN THE DECK SHALL BE SAWED PRIOR TO THE CASTING OF BARRIER RAIL. ALL REINFORCING STEEL IN BARRIER RAILS SHALL BE EPOXY COATED.

THE #5 S3 AND #5 S4 BARS SHALL BE INSTALLED, USING AN ADHESIVE ANCHORING SYSTEM, AFTER SAWING THE JOINT. FOR ADHESIVELY ANCHORED ANCHOR BOLTS OR DOWELS, SEE SPECIAL PROVISIONS. THE YIELD LOAD FOR THE #5 S3 AND #5 S4 BARS IS 18.6 KIPS. FIELD TESTING FOR THE ADHESIVE BONDING SYSTEM IS NOT REQUIRED.

VERTICAL GROOVED CONTRACTION JOINTS, 1/2" IN DEPTH, SHALL BE TOOLED IN ALL EXPOSED FACES OF THE BARRIER RAIL AND IN ACCORDANCE WITH ARTICLE 825-10(B) OF THE STANDARD SPECIFICATIONS. THE CONTRACTION JOINT SHALL BE LOCATED AT EACH THIRD POINT BETWEEN BARRIER RAIL EXPANSION JOINTS. ONLY ONE CONTRACTION JOINT IS REQUIRED AT MIDPOINT OF BARRIER RAIL SEGMENTS LESS THAN 20 FEET IN LENGTH AND NO CONTRACTION JOINTS ARE REQUIRED FOR THOSE SEGMENTS LESS THAN 10 FEET IN LENGTH.

**BAR TYPES**

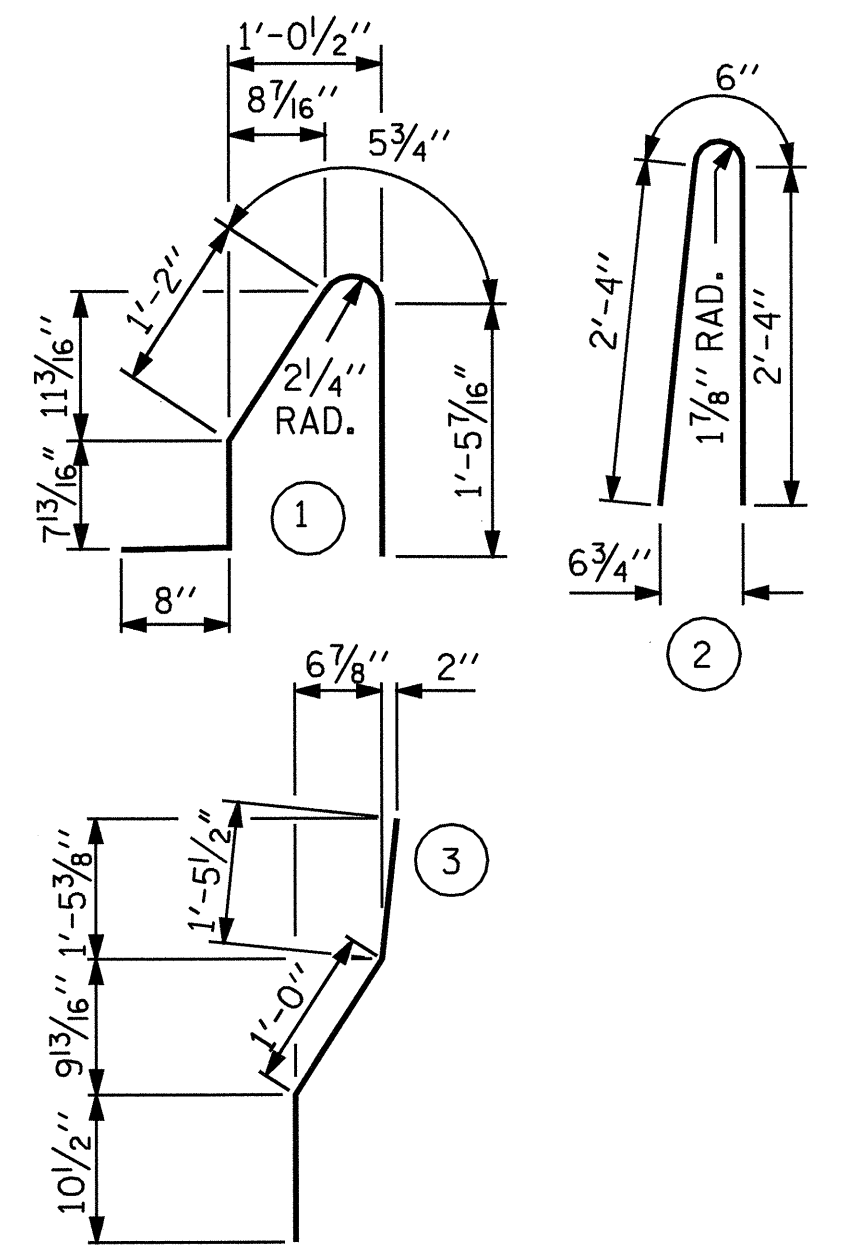

ALL BAR DIMENSIONS ARE OUT TO OUT

**BILL OF MATERIAL**

| FOR CONCRETE BARRIER RAIL ONLY   |     |      |      |         |                 |
|----------------------------------|-----|------|------|---------|-----------------|
| BAR                              | NO. | SIZE | TYPE | LENGTH  | WEIGHT          |
| *B1                              | 14  | #5   | STR  | 16'-11" | 247             |
| *B2                              | 70  | #5   | STR  | 21'-4"  | 1558            |
| *B3                              | 14  | #5   | STR  | 21'-11" | 320             |
| *S1                              | 286 | #5   | 1    | 4'-5"   | 1317            |
| *S2                              | 286 | #5   | 2    | 5'-2"   | 1541            |
| *S3                              | 12  | #5   | 3    | 3'-4"   | 42              |
| *S4                              | 12  | #5   | STR  | 3'-2"   | 40              |
| * EPOXY COATED REINFORCING STEEL |     |      |      |         | 5,065 LBS.      |
| CLASS AA CONCRETE                |     |      |      |         | 29.6 CU. YDS.   |
| CONCRETE BARRIER RAIL            |     |      |      |         | 295.83 LIN. FT. |

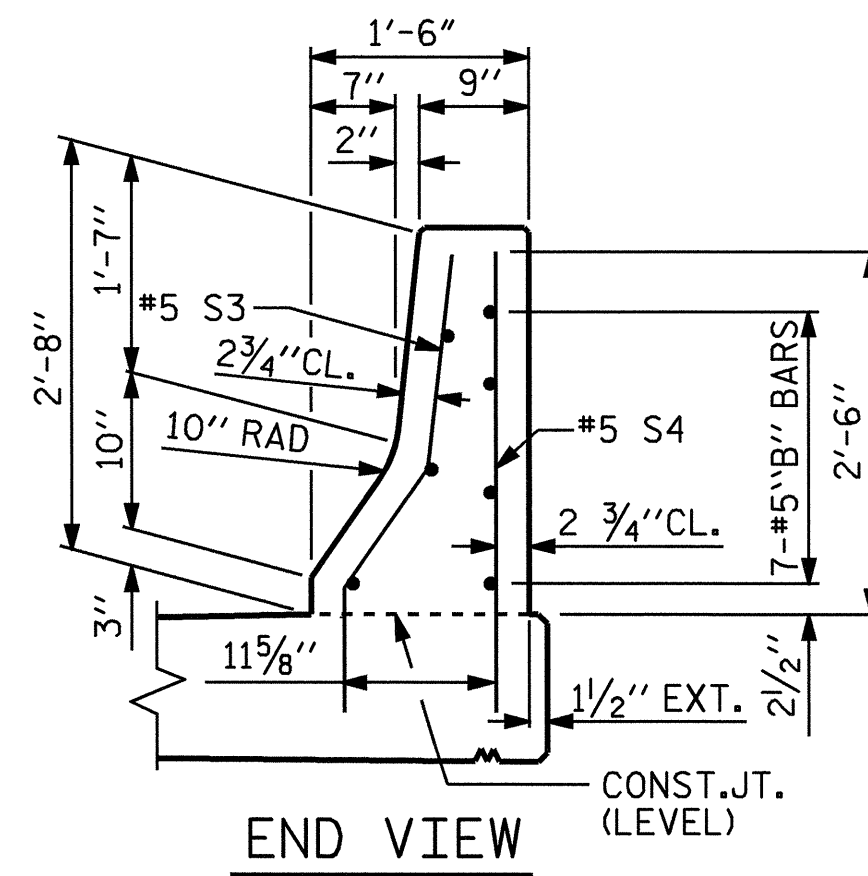
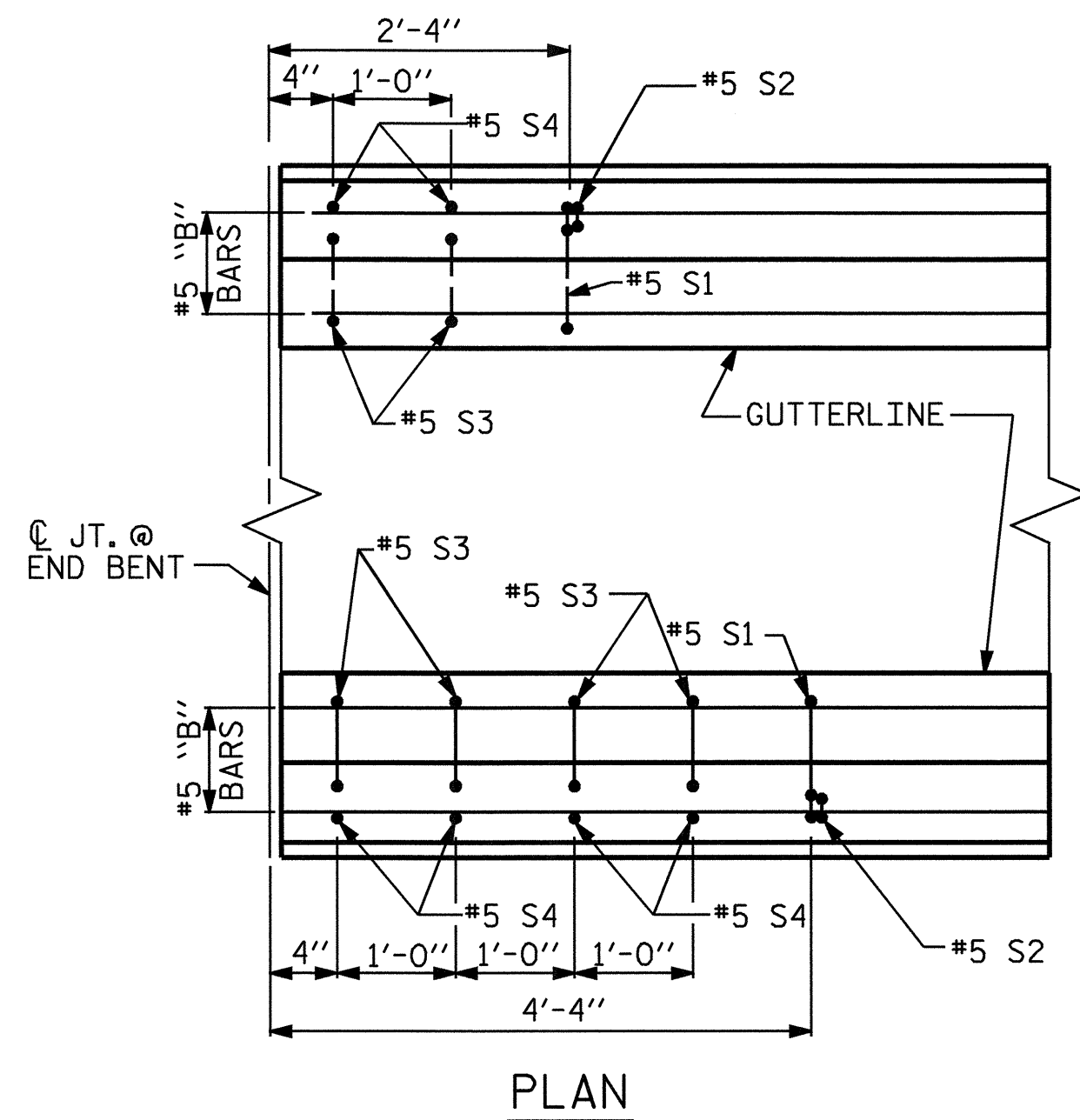

**END OF RAIL DETAILS**

FOR ADHESIVE ANCHORING AT SAWED JOINTS

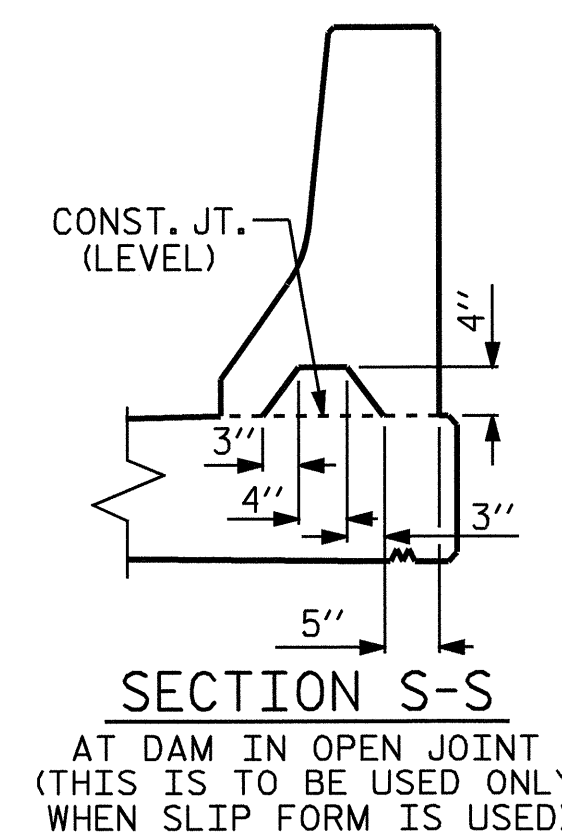
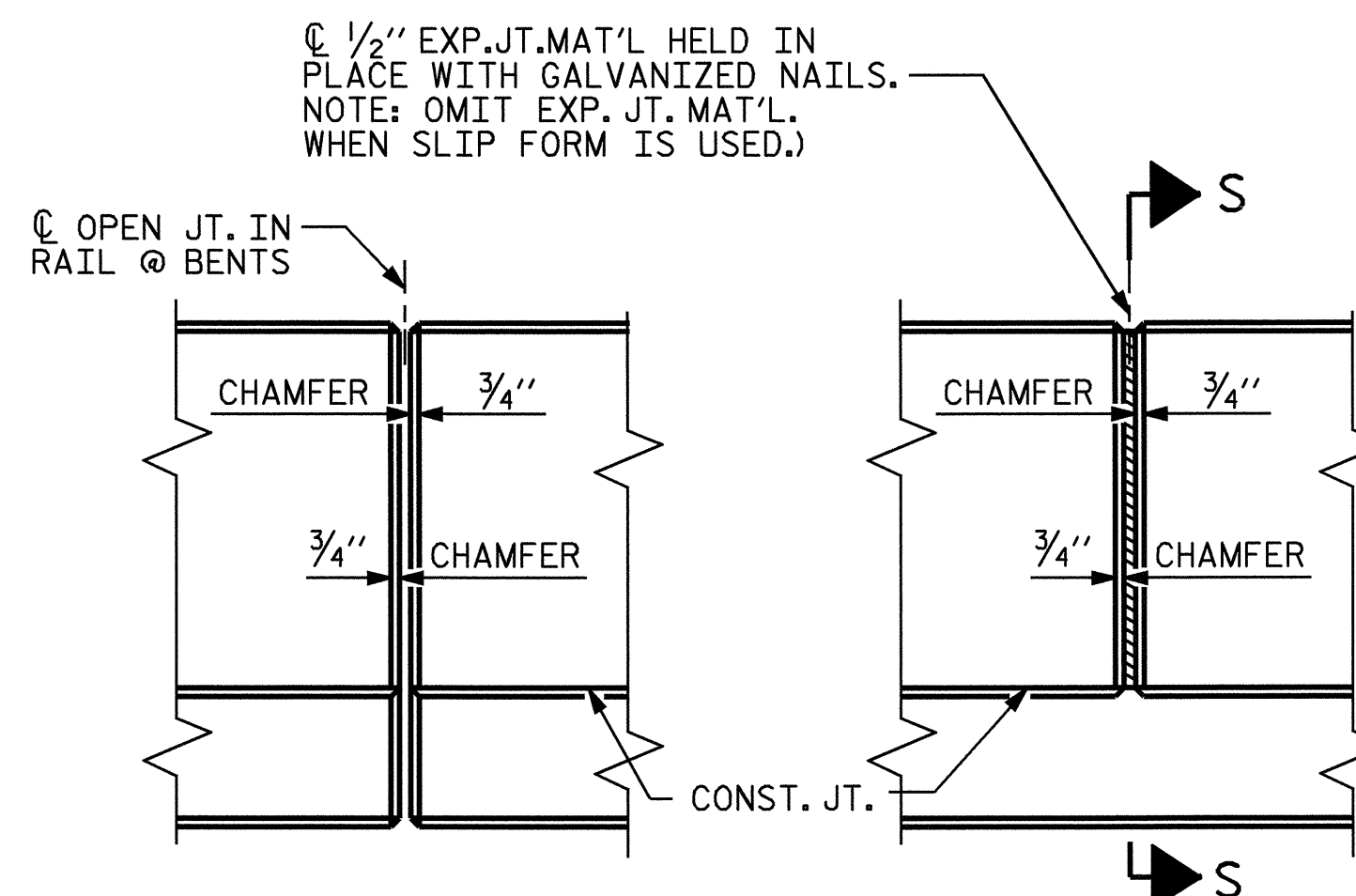
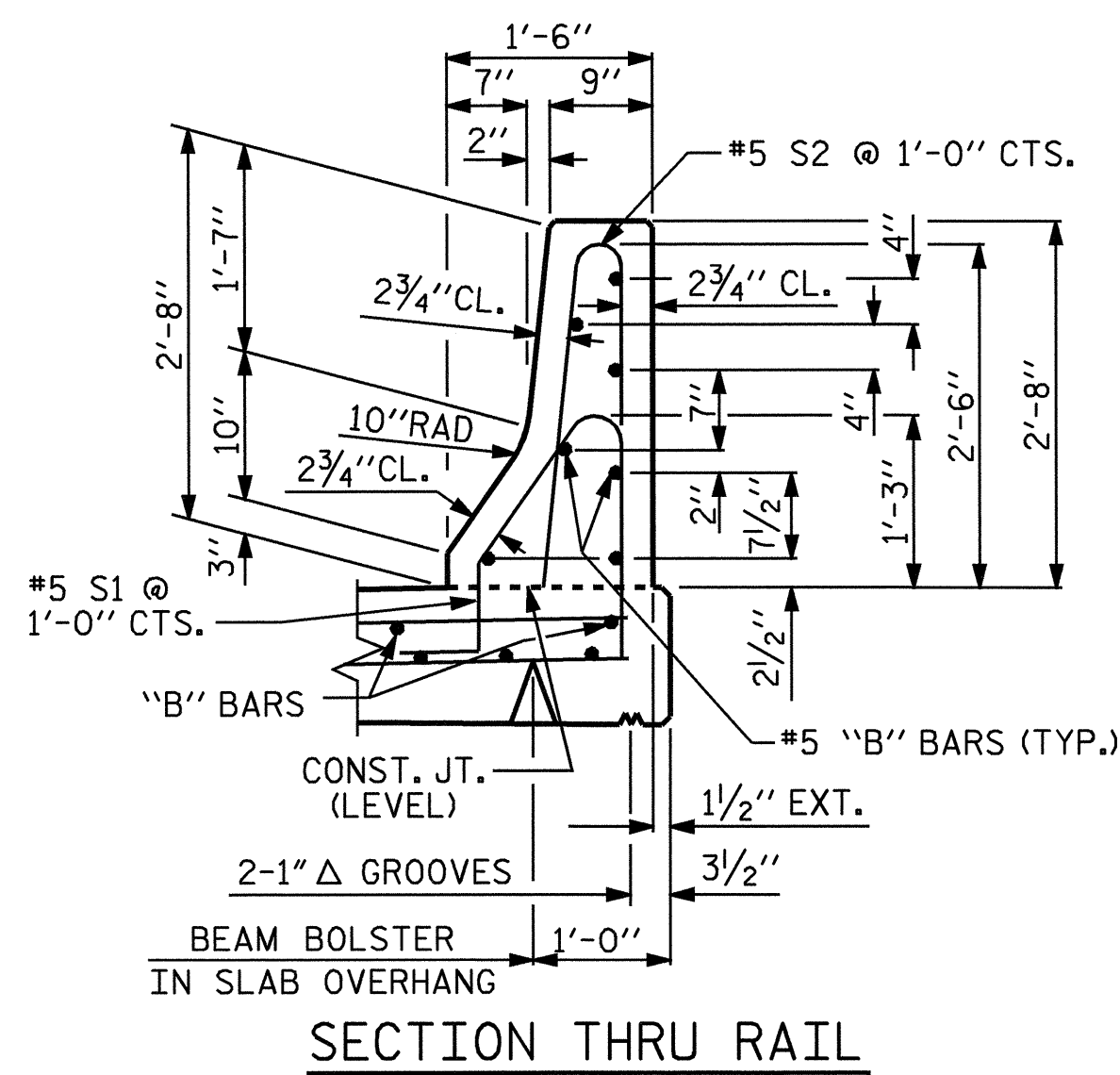

**ELEVATION AT EXPANSION JOINTS**

**BARRIER RAIL DETAILS**

PROJECT NO. B-3714  
WILKES COUNTY  
 STATION: 17+05.50 -L-

SHEET 2 OF 2

STATE OF NORTH CAROLINA  
 DEPARTMENT OF TRANSPORTATION  
 RALEIGH

**STANDARD  
 CONCRETE  
 BARRIER RAIL**



| REVISIONS |     |       |     |     |       | TOTAL SHEETS |
|-----------|-----|-------|-----|-----|-------|--------------|
| NO.       | BY: | DATE: | NO. | BY: | DATE: | 35           |
| 1         |     |       | 3   |     |       |              |
| 2         |     |       | 4   |     |       |              |

|                            |                       |
|----------------------------|-----------------------|
| ASSEMBLED BY : P.C. BREWER | DATE : 7/9/04         |
| CHECKED BY : K.W. ALFORD   | DATE : 8/6/04         |
| DRAWN BY : ARB 5/87        | REV. 8/16/99 RWW/LES  |
| CHECKED BY : SJD 9/87      | REV. 10/17/00 RWW/LES |
|                            | REV. 5/7/03R RWW/JTE  |