

22-MAY-2003 13:59
 C:\Special Details\erickward\stds\02\Spec to Special Details\english\86202\0862d02.dgn
 erickward
 5/14/99

STATE OF NORTH CAROLINA
 DEPT. OF TRANSPORTATION
 DIVISION OF HIGHWAYS
 RALEIGH, N.C.

ENGLISH DETAIL DRAWING FOR
 GUARDRAIL INSTALLATION

SHEET 1 OF 7
 862D02

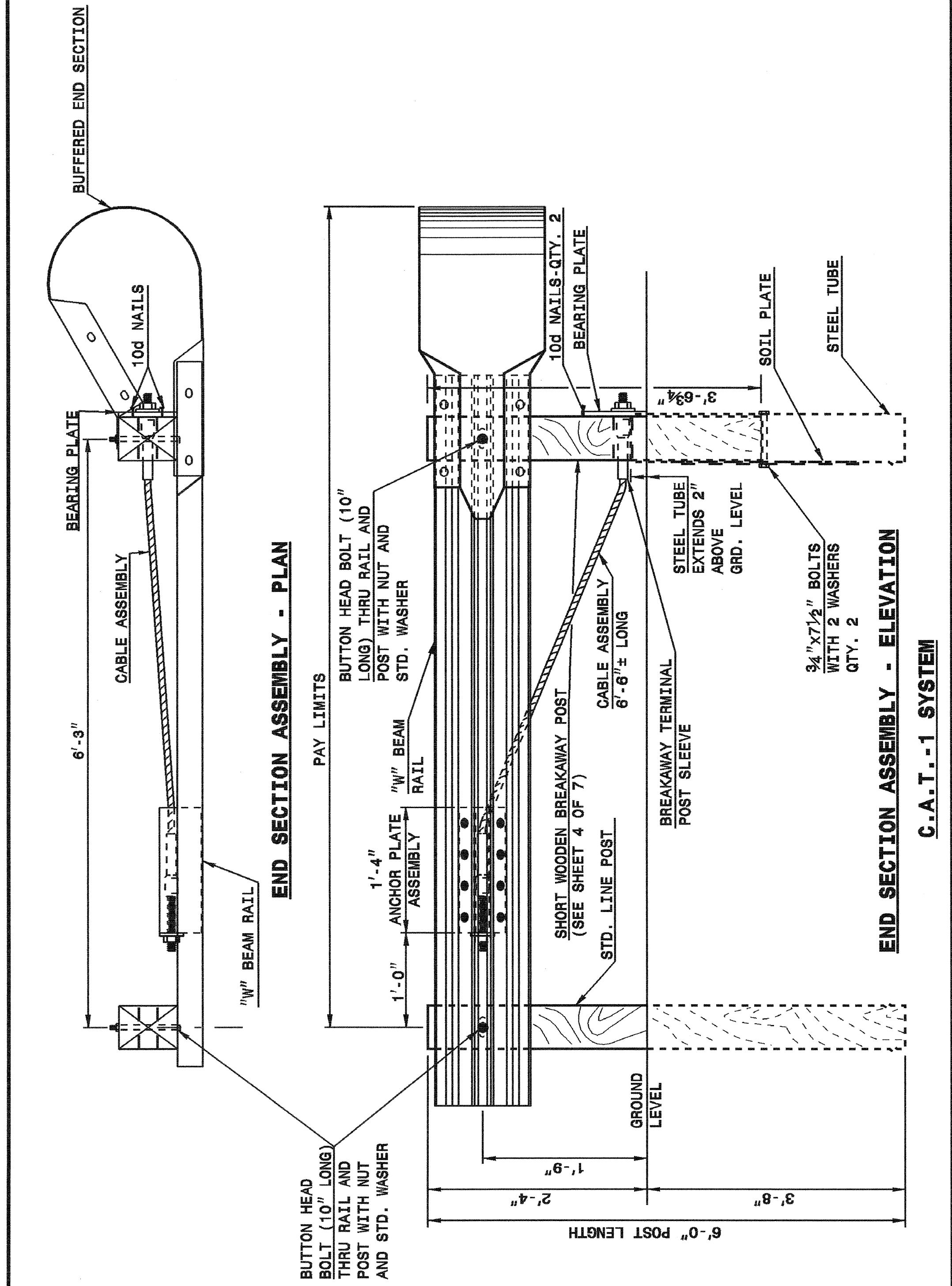

STATE OF NORTH CAROLINA
 DEPT. OF TRANSPORTATION
 DIVISION OF HIGHWAYS
 RALEIGH, N.C.

ENGLISH DETAIL DRAWING FOR
 GUARDRAIL INSTALLATION

SHEET 1 OF 7
 862D02

STATE OF NORTH CAROLINA
 DEPT. OF TRANSPORTATION
 DIVISION OF HIGHWAYS
 RALEIGH, N.C.

ENGLISH DETAIL DRAWING FOR
 GUARDRAIL INSTALLATION

SHEET 2 OF 7
 862D02

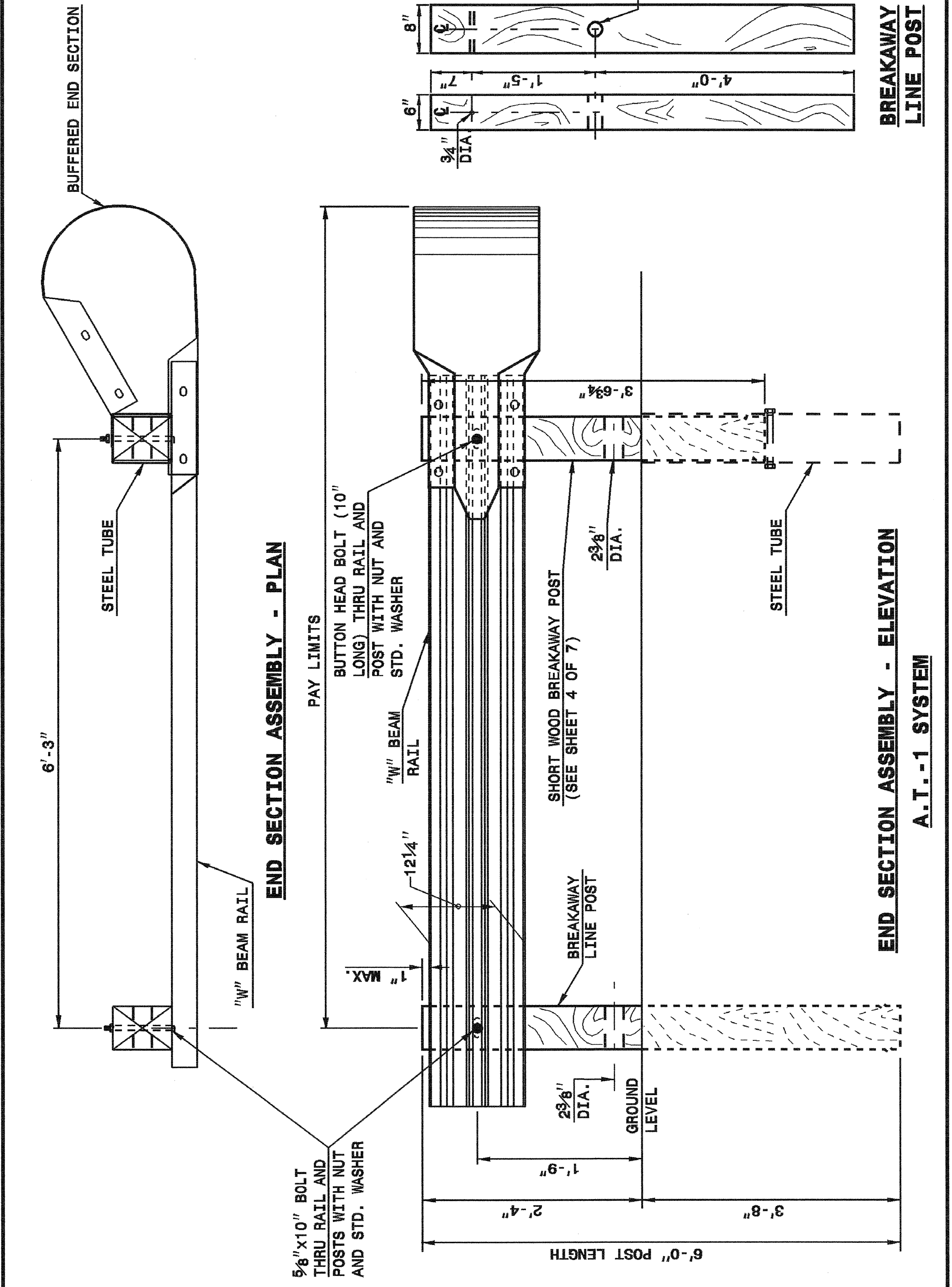

STATE OF NORTH CAROLINA
 DEPT. OF TRANSPORTATION
 DIVISION OF HIGHWAYS
 RALEIGH, N.C.

ENGLISH DETAIL DRAWING FOR
 GUARDRAIL INSTALLATION

SHEET 2 OF 7
 862D02

DESIGN SERVICES UNIT
 STANDARDS AND SPECIAL DESIGN
 Office 919-250-4128 FAX 919-250-4119

SEE PLATE FOR TITLE

ORIGINAL BY: 2002 STD.862.02 DATE:
 MODIFIED BY: E.E. WARD DATE: 02-09-03
 CHECKED BY: DATE:
 FILE SPEC.: /usr/stds/02todetail/english/86202/862d02.dgn

