

**NOTES:**

STIRRUPS IN CAP MAY BE SHIFTED AS NECESSARY TO CLEAR ANCHOR BOLTS.

THE LATERAL GUIDE AT EACH END OF THE CAP IS NOT TO BE POURED UNTIL AFTER THE CORED SLAB UNITS ARE IN PLACE.

THE CONTRACTOR SHALL PROVIDE FOR INSTALLATION OF THE 4" DIAMETER DRAIN PIPE THROUGH THE WING WALL AS REQUIRED FOR REINFORCED BRIDGE APPROACH FILLS. SEE THE ROADWAY PLANS. REINFORCING STEEL IN THE WING WALL MAY BE SHIFTED AS NECESSARY TO CLEAR THE DRAIN PIPE.

THE TOP SURFACE OF THE END BENT CAP IS SLOPED LONGITUDINALLY ALONG CENTERLINE OF THE CORED SLAB UNIT TO MATCH GRADE.

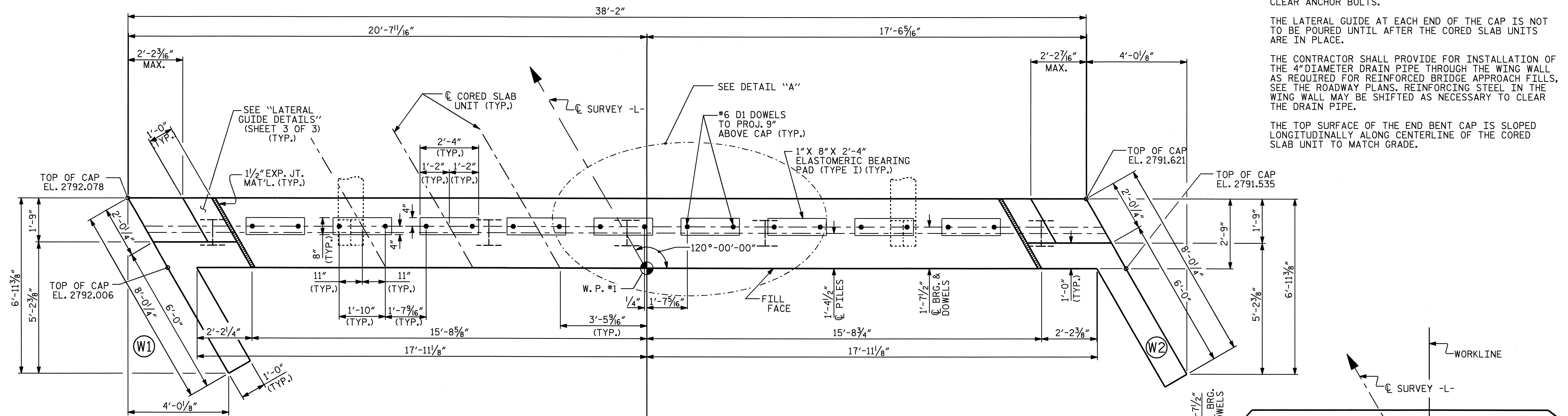

**PLAN**

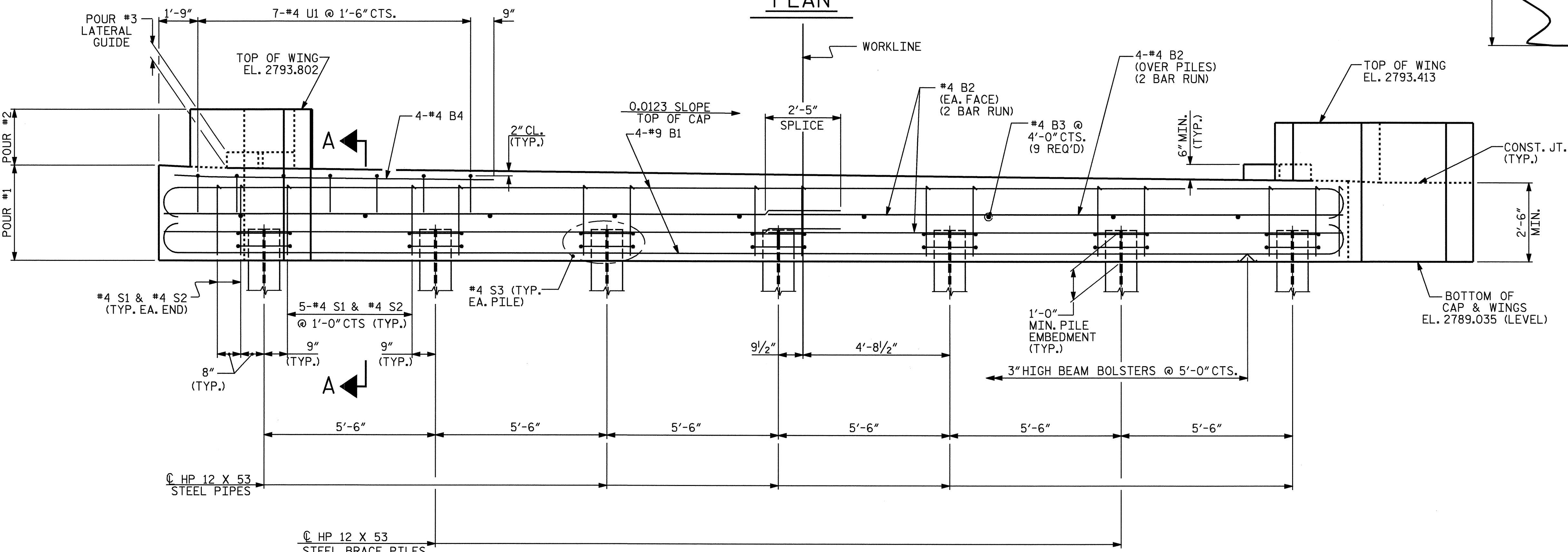

**ELEVATION**

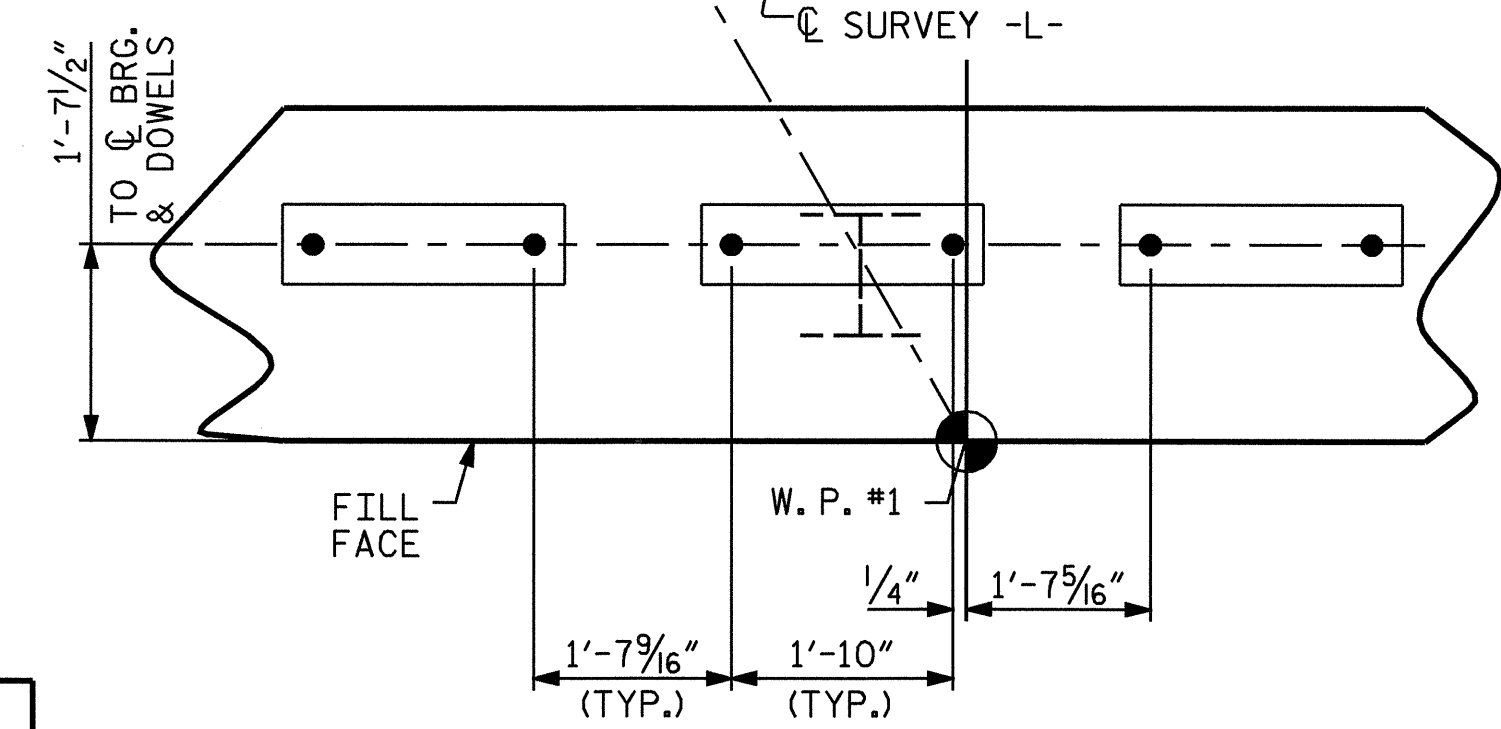

**DETAIL "A"**

PROJECT NO. B-3709  
WATAUGA COUNTY  
 STATION: 16+99.00 -L-

SHEET 1 OF 3

STATE OF NORTH CAROLINA  
 DEPARTMENT OF TRANSPORTATION  
 RALEIGH

SUBSTRUCTURE  
 END BENT No. 1



REVISIONS						SHEET NO.	
NO.	BY:	DATE:	NO.	BY:	DATE:	S-9	
1			3			TOTAL SHEETS	
2			4			23	

DRAWN BY: R. G. EMERSON DATE: 10/04  
 CHECKED BY: A. R. CHESSON DATE: 11/04