

PLAN OF SPAN "E"  
\* DENOTES RADIAL DIMENSION

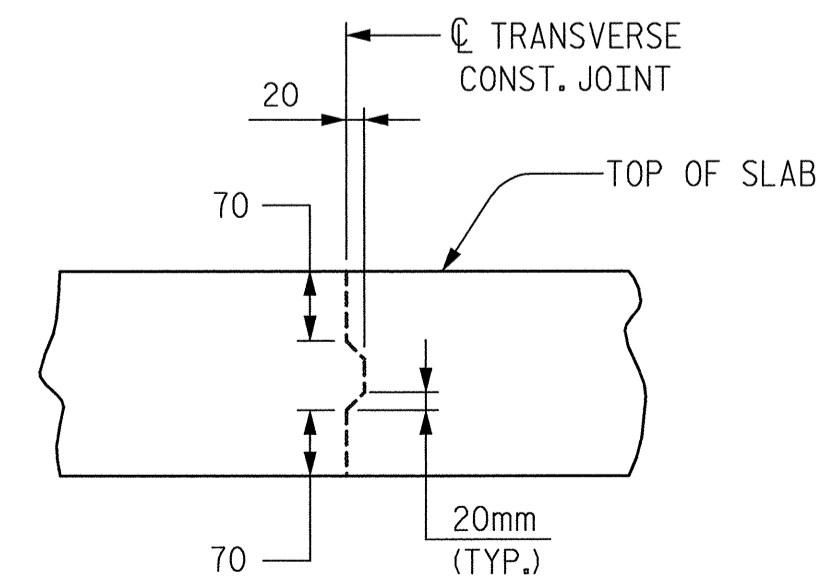

TRANSVERSE CONSTRUCTION JOINT DETAIL

NOTE: REINFORCING STEEL IN THE SLAB NOT SHOWN. SLAB REINFORCING STEEL SHALL BE CONTINUOUS THRU JOINT.



PROJECT NO. R-2552AB  
JOHNSTON COUNTY  
STATION: 40+96.000 -L- P.O.C.  
SHEET 4 OF 8

TRANSYSTEMS CORPORATION  
75 Beattie Place, Suite 400  
Greenville, SC 29601 (864) 234-0866

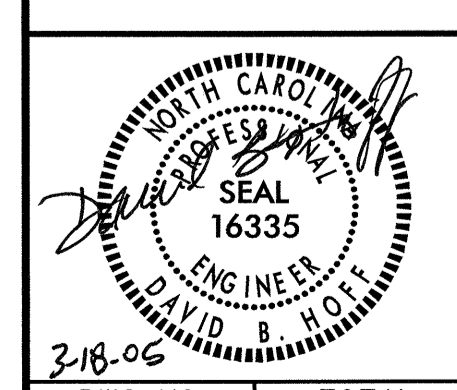

STATE OF NORTH CAROLINA  
DEPARTMENT OF TRANSPORTATION  
RALEIGH

SUPERSTRUCTURE  
PLAN OF SPAN "E"  
(RIGHT LANE)

DRAWN BY: J. B. GEILE DATE: 9/01  
CHECKED BY: M. L. MARLEY DATE: 12/01

REVISIONS						SHEET NO.
NO.	BY:	DATE:	NO.	BY:	DATE:	5-344
1			3			TOTAL SHEETS
2			4			429

g:\v\04\0125\bridge\stet\right (eb)\v\final\span-eb1.dgn  
3/17/2005  
10:38:17 AM