

72.700m (FILL FACE AT END BENT #1 TO FILL FACE AT END BENT #2)

SPAN "A" = 36.700m (FILL FACE AT END BENT #1 TO C/BENT #1)

SPAN "B" = 36.000m (C/BENT #1 TO FILL FACE AT END BENT #2)

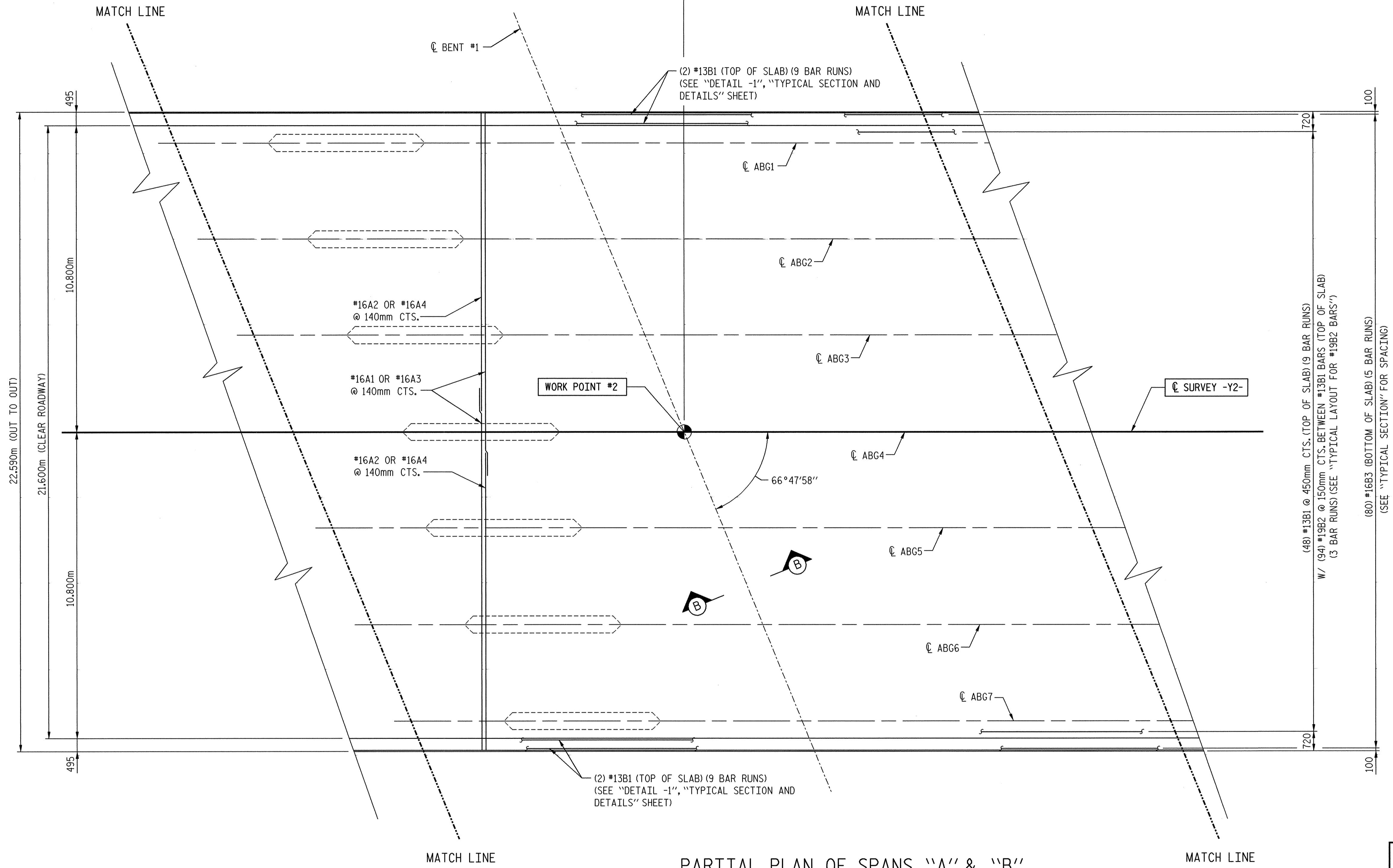

- NOTES:**
- FOR CONCRETE BARRIER RAIL REINFORCING STEEL THAT MUST BE CAST IN DECK SLAB, SEE "CONCRETE BARRIER RAIL" SHEET.
  - FOR SECTION "B-B", SEE "TYPICAL SECTION AND DETAILS" SHEET.

PARTIAL PLAN OF SPANS "A" & "B"

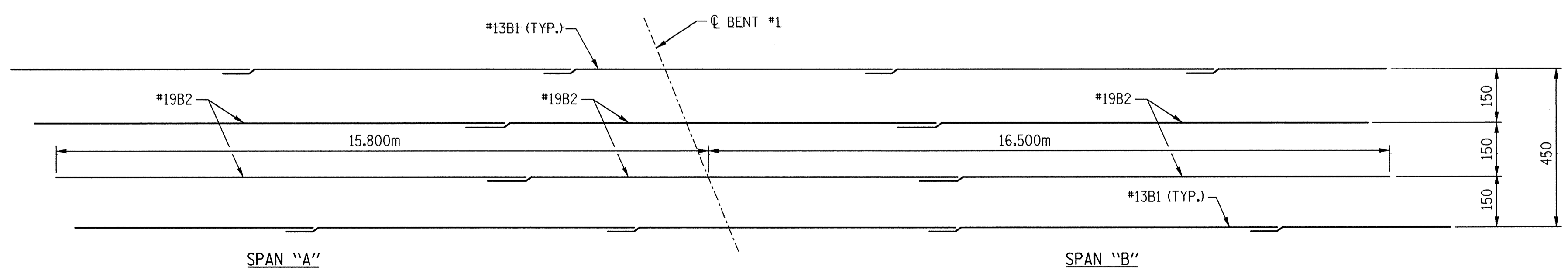

TYPICAL LAYOUT FOR #19B2 BARS

PROJECT NO. R-2552AB  
JOHNSTON COUNTY  
 STATION: 52+34.693 -L- =  
18+60.011 -Y2-

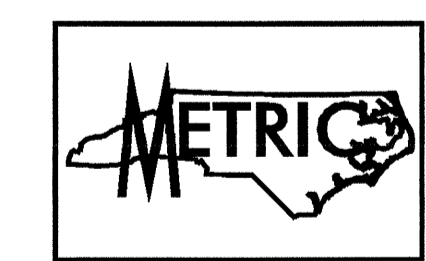

**TRANSYSTEMS CORPORATION**  
 75 Beattie Place, Suite 400  
 Greenville, SC 29601 (864) 234-0866

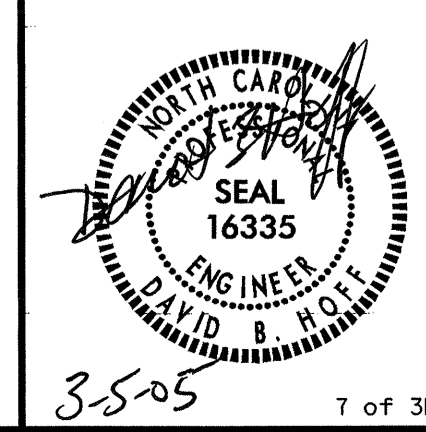

STATE OF NORTH CAROLINA  
**DEPARTMENT OF TRANSPORTATION**  
 RALEIGH  
**SUPERSTRUCTURE**  
**PARTIAL PLAN OF**  
**SPANS "A" & "B"**

REVISIONS						SHEET NO.	
NO.	BY:	DATE:	NO.	BY:	DATE:		
1			3			S-405	
2			4			TOTAL SHEETS 429	

DRAWN BY: M.T. BELISLE DATE: 4/01  
 CHECKED BY: D.B. HOFF DATE: 10/01

g:\04\04\_0125\Bridg\Site2\Final\11\_25\_03\1004span-ab.dgn  
 3/4/2005 2:49:30 PM

35-25 7 of 31