

6/16/93

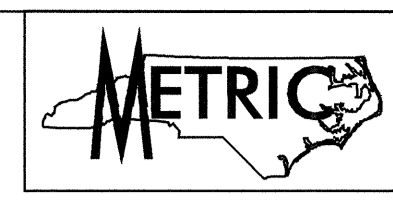

PROJECT REFERENCE NO. R-2552AB	SHEET NO. 2-B
ROADWAY DESIGN ENGINEER <i>[Signature]</i>	PAVEMENT DESIGN ENGINEER <i>[Signature]</i>

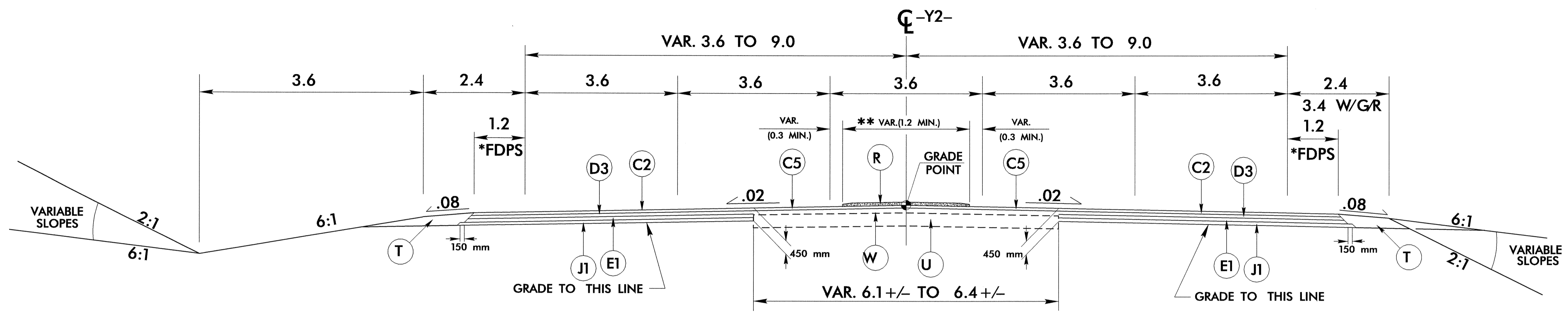

TYPICAL SECTION NO. 5
*FULL DEPTH PAVED SHOULDER

USE TYPICAL SECTION NO. 5 AS FOLLOWS:

- Y2- 15+05 +/- TO 18+23.311 (BEGIN BRIDGE)
- Y2- 18+96.011 (END BRIDGE) TO 21+75 +/-
- ** SEE PLANS FOR LOCATION

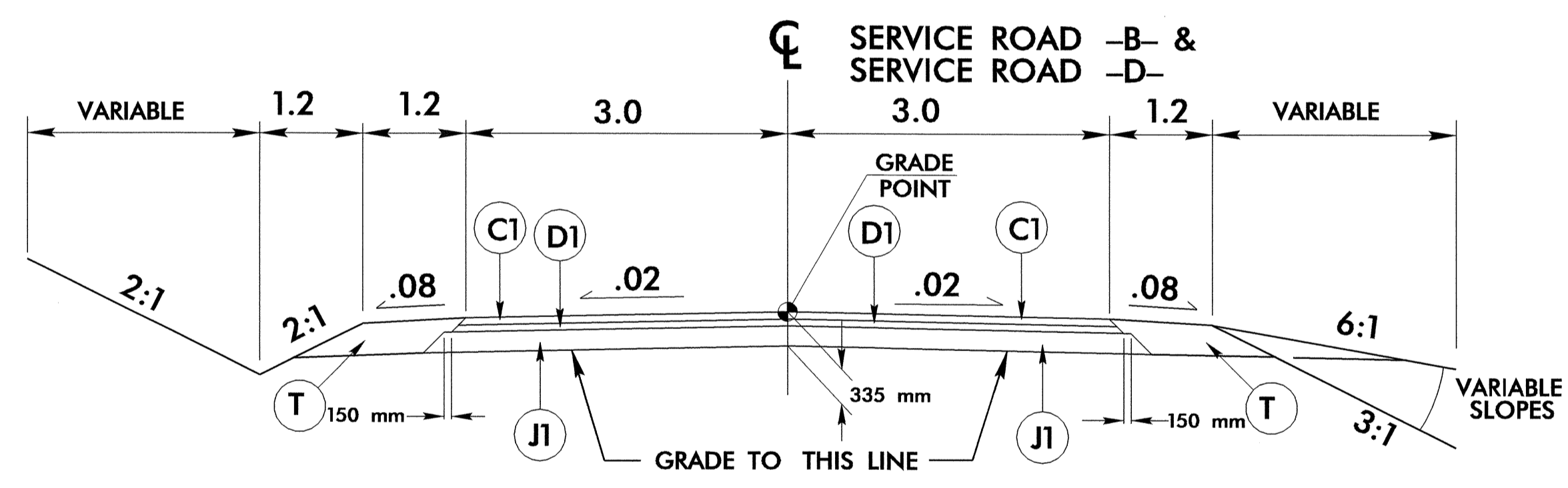

TYPICAL SECTION NO. 6

USE TYPICAL SECTION NO. 6 AS FOLLOWS:
SERVICE ROAD -B- 9+93.200 TO 15+67.450
SERVICE ROAD -D- 9+90.000 TO 13+00.920

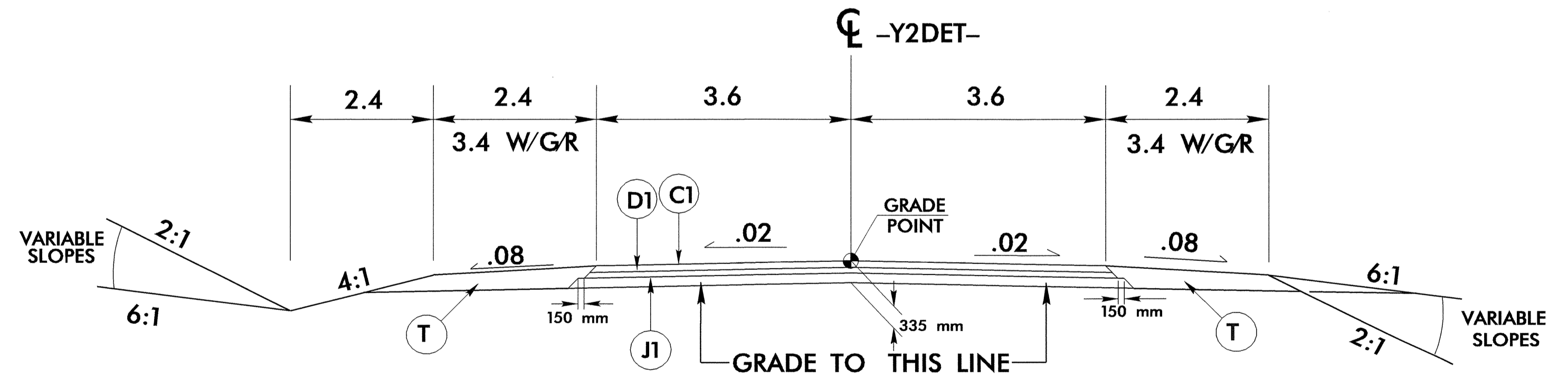

TYPICAL SECTION NO. 7

USE TYPICAL SECTION NO. 7 AS FOLLOWS:
-Y2DET- 16+58.778 TO 20+78.437

PAVEMENT SCHEDULE	
C1	70 mm S9.5B
C2	80 mm S9.5C
C3	100 mm S12.5C
C4	VAR. DEPTH S9.5C
C5	40 mm S9.5C
D1	65 mm I19.0B
D2	65 mm I19.0C
D3	80 mm I19.0C
D4	100 mm I19.0C
D5	VAR. DEPTH I19.0C
E1	90 mm B25.0C
E2	100 mm B25.0C
E3	180 mm B25.0C
E4	VAR. DEPTH B25.0C
J1	200 mm AGGREGATE BASE COURSE.
J2	250 mm AGGREGATE BASE COURSE.
J3	VAR. DEPTH AGGREGATE BASE CORSE.
L	SUBGRADE STABILIZATION
P	PRIME COAT
R	125 mm MONO. CONC ISLAND
T	EARTH MATERIAL
U	EXISTING PAVEMENT
W	VARIABLE DEPTH ASPHALT PAVEMENT

NOTE:
PAVEMENT EDGE SLOPES ARE 1:1 UNLESS SHOWN OTHERWISE.