

EDI MODEL 2010ECL CONFLICT MONITOR

PROGRAMMING DETAIL

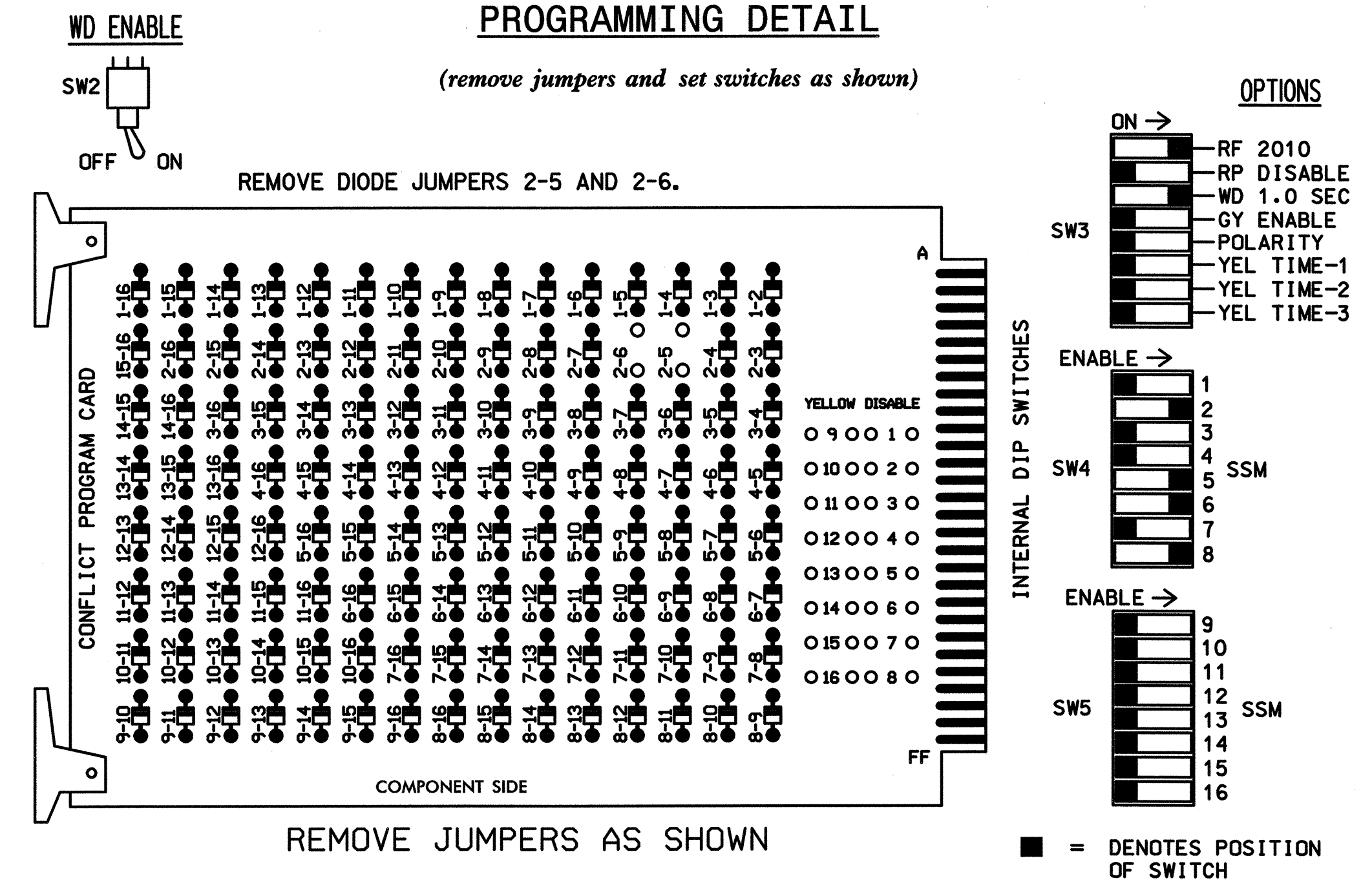

NOTES:

- CARD IS PROVIDED WITH ALL DIODE JUMPERS IN PLACE. REMOVAL OF ANY JUMPER ALLOWS ITS CHANNELS TO RUN CONCURRENTLY.
- MAKE SURE JUMPERS SEL1-SEL5 ARE PRESENT ON THE MONITOR BOARD.

NOTES

- TO PREVENT "FLASH-CONFLICT" PROBLEMS, INSERT RED FLASH PROGRAM BLOCKS FOR ALL UNUSED VEHICLE LOAD SWITCHES IN THE OUTPUT FILE. THE INSTALLER SHALL VERIFY THAT SIGNAL HEADS FLASH IN ACCORDANCE WITH THE SIGNAL PLANS.
- ENSURE THAT RED ENABLE IS ACTIVE AT ALL TIMES DURING NORMAL OPERATION. TO PREVENT RED FAILURES ON UNUSED MONITOR CHANNELS, TIE UNUSED RED MONITOR INPUTS 1,3,4,7,9,10,11,12,13,14,15 & 16 TO LOAD SWITCH AC+ PER CABINET MANUFACTURER'S INSTRUCTIONS.
- PROGRAM CONTROLLER TO START UP IN PHASES 2 AND 6 GREEN.
- ENABLE SIMULTANEOUS GAP-OUT FEATURE, ON CONTROLLER UNIT, FOR ALL PHASES.
- PROGRAM PHASES 2 AND 6, ON CONTROLLER UNIT, FOR VARIABLE INITIAL AND GAP REDUCTION.
- IF AN APPROVED EQUIVALENT OF TC-26B MICROWAVE DETECTOR IS USED, DISREGARD MICROWAVE DETECTOR WIRING DETAIL SHOWN BELOW. INSTALL ACCORDING TO MANUFACTURER'S INSTRUCTIONS. SENSOR SHALL BE WIRED SUCH THAT INPUT INTERFACE TO THE CONTROLLER IS ACHIEVED THROUGH ISOLATION CIRCUITRY.
- THE CABINET AND CONTROLLER ARE PART OF THE NC 42 CLOSED LOOP SYSTEM.

EQUIPMENT INFORMATION

CONTROLLER.....CONTRACTOR SUPPLIED 2070L
 CABINETCONTRACTOR SUPPLIED 332
 SOFTWAREECONOLITE OASIS
 CABINET MOUNT.....BASE
 OUTPUT FILE POSITIONS...12
 LOAD SWITCHES USED.....S2,S5,S6,S8
 PHASES USED.....2,5,6,8
 OVERLAPS.....NONE

FIELD CONNECTION HOOK-UP CHART

LOAD SWITCH NO.	S1	S2	S2P	S3	S4	S4P	S5	S6	S6P	S7	S8	S8P
PHASE	1	2	2 PED	3	4	4 PED	5	6	6 PED	7	8	8 PED
SIGNAL HEAD NO.	NU	21,22	NU	NU	NU	NU	21	61,62	NU	NU	81,82	NU
GREEN		130						136			109	
YELLOW		129						135			108	
RED		128					*	134			107	
RED ARROW												
YELLOW ARROW								132				
GREEN ARROW								133				
⚠												
⚠												

NU = NOT USED
 * DENOTES INSTALL LOAD RESISTOR. SEE LOAD RESISTOR INSTALLATION DETAIL THIS PAGE.

INPUT FILE POSITION LAYOUT

(front view)

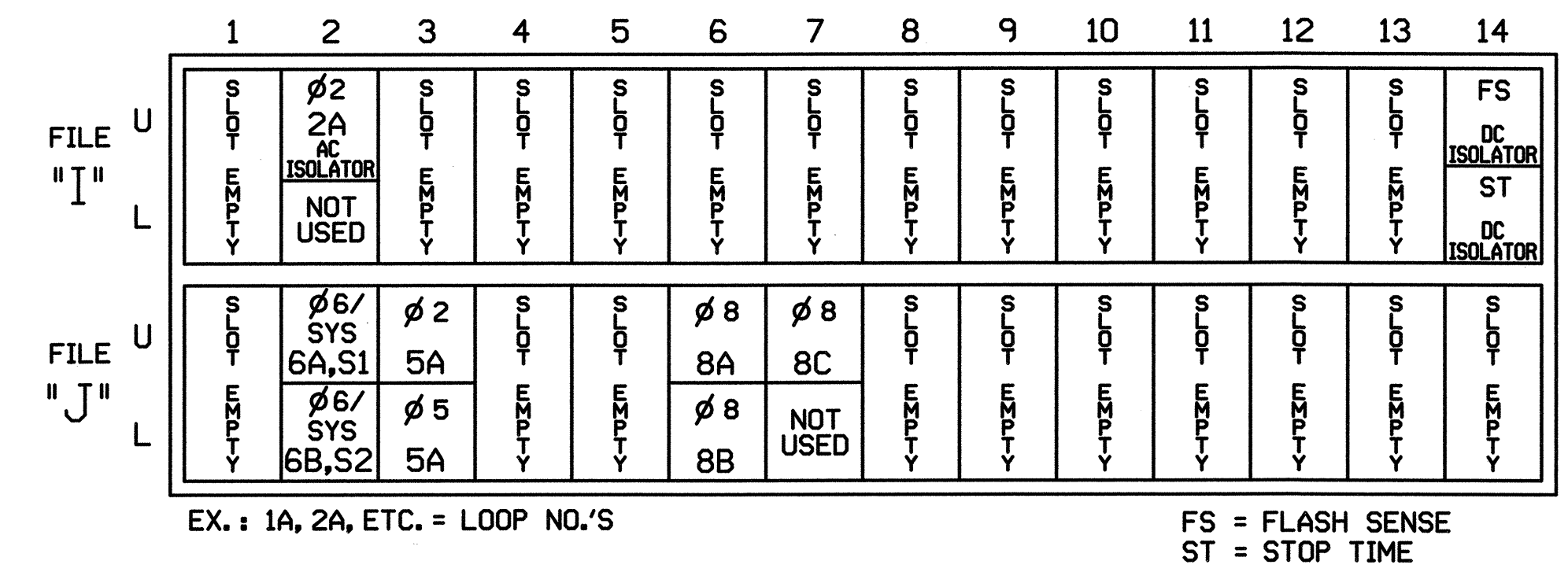

INPUT FILE CONNECTION & PROGRAMMING CHART

LOOP NO.	LOOP TERMINAL	INPUT FILE POS.	PIN NO.	INPUT ASSIGNMENT NO.	DETECTOR NO.	NEMA PHASE	CALL	EXTEND	FULL TIME DELAY	STRETCH TIME	DELAY TIME
2A	*	I2U	39	1	2	2	Y	Y	-	-	-
6A,S1	TB3-5,6	J2U	40	2	6	6/SYS	Y	Y	-	-	-
6B,S2	TB3-7,8	J2L	44	6	16	6/SYS	Y	Y	-	-	-
5A ¹	TB3-9,10	J3U	64	26	36	2	Y	Y	Y	-	3
	TB3-11,12	J3L	77	39	46	5	Y	Y	-	-	15
8A	TB5-9,10	J6U	42	4	8	8	Y	Y	-	-	-
8B	TB5-11,12	J6L	46	8	18	8	Y	Y	-	-	-
8C	TB7-1,2	J7U	66	28	38	8	Y	Y	-	-	20

¹ ADD JUMPERS FROM TB3-9 TO TB3-11, AND FROM TB3-10 TO TB3-12.
 * MICROWAVE DETECTOR. SEE 'MICROWAVE DETECTOR WIRING DETAIL'

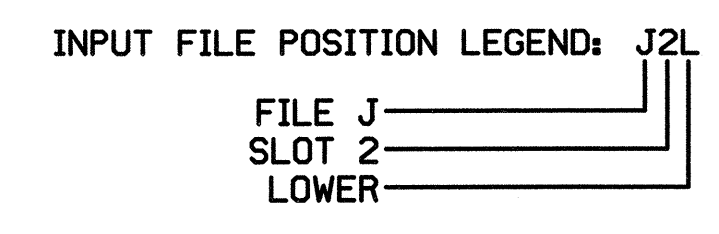

MICROWAVE DETECTOR WIRING DETAIL

(wire as shown)

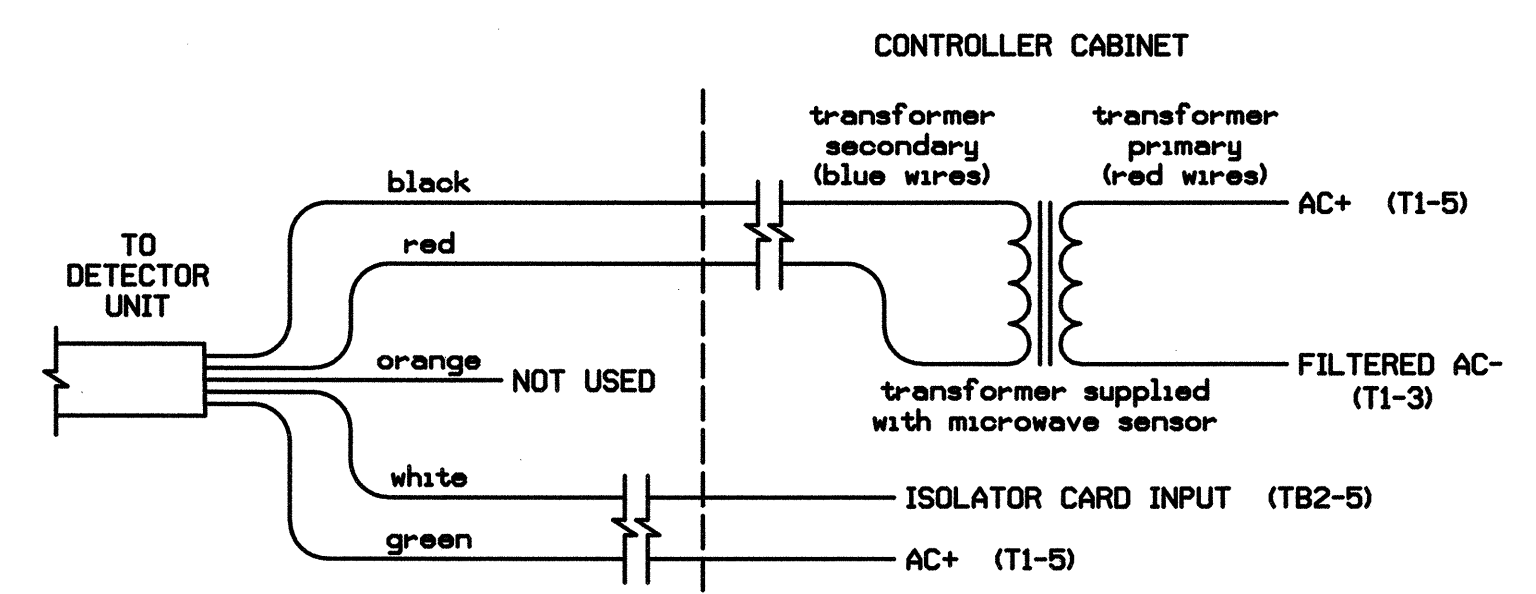

TC26B WIRE LIST

COLOR	FUNCTION
black	12V to 24V AC/DC (no polarity)
red	12V to 24V AC/DC (no polarity)
orange	Output Relay Normally Open
white	Output Relay Normally Closed
green	Output Relay Common

NOTES:

- SENSOR IS A MICROWAVE SENSORS, INC. MODEL TC-26B MICROWAVE MOTION DETECTOR MOUNTED ON POLES AS INDICATED ON SIGNAL DESIGN PLANS.
- CONFIGURE AC ISOLATOR CARD TO PLACE CALL UPON REMOVAL OF AC+ FROM THE INPUT.
- IMPORTANT: FOR PROPER OPERATION OF THE MICROWAVE DETECTOR, REMOVE SURGE PROTECTION FROM TB2-5 AND TB2-6. TIE TB2-6 TO AC NEUTRAL.

LOAD RESISTOR INSTALLATION DETAIL

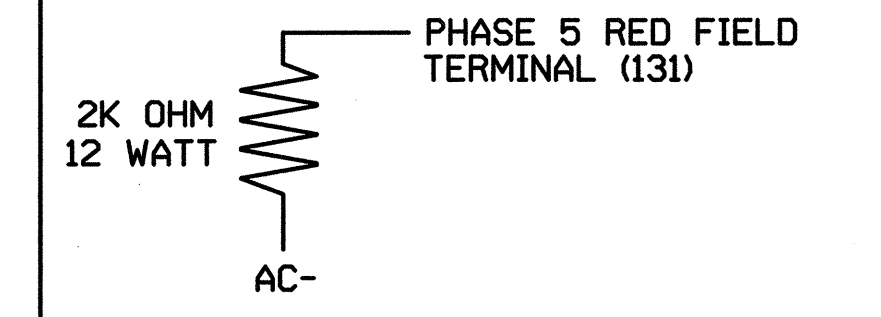

NOTE: THE PURPOSE OF THIS RESISTOR IS TO LOAD THE CHANNEL RED MONITOR INPUT IN ORDER FOR THE SIGNAL SEQUENCE MONITOR TO USE THE FULL SIGNAL SEQUENCE MONITORING CAPABILITY ON CHANNELS THAT DO NOT USE THE RED DISPLAY IN THE FIELD.

THIS ELECTRICAL DETAIL IS FOR THE SIGNAL DESIGN: 04-1261
 DESIGNED: 11-04
 SEALED: 01-10-05
 REVISED:

TYPE 2070L CONTROLLER & 332 CABINET

New Signal Design

NC 42
 At
 US 70 Bypass WB Ramps

Division 04 Johnston County S of Clayton

PLAN DATE: November 2004 REVIEWED BY: S.T. Franklin

PREPARED BY: T.R. Terrell REVIEWED BY: H.L. Winstead

REVISIONS

INIT. DATE

SEAL

NORTH CAROLINA PROFESSIONAL ENGINEER
 HARVEY L. WINSTEAD, P.E.
 SEAL 07983

HNTB

HNTB NORTH CAROLINA, P.C.
 343 E. Six Forks Road, Suite 200
 Raleigh, North Carolina 27609

HNTB

SIG. INVENTORY NO. 04-1261