

8/17/99

DETAIL OF TEMPORARY MEDIAN CROSSOVERS ON I-40 FOR PLACEMENT OF STEEL GIRDERS

 5 0 10 CONST. REV. R / W REV.	PROJECT REFERENCE NO. R-2552AA SHEET NO. 2-0 ROADWAY DESIGN ENGINEER  3/16/05
---	--

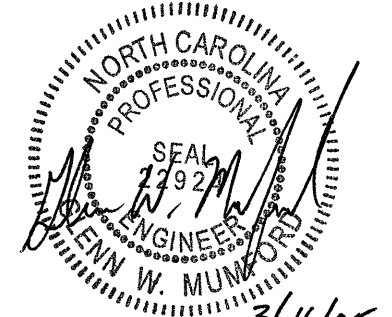
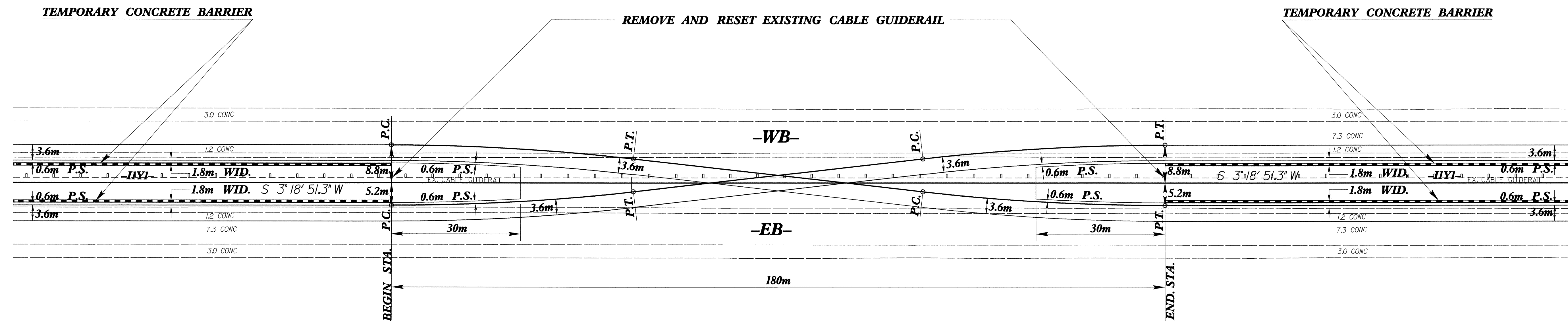

LOCATION	BEGIN STA.	END STA.	Rc	DELTA	Lc
1	13+74.000	15+54.000	500m	6° 28' 02"	56.437m
2	23+34.000	25+14.000	500m	6° 28' 02"	56.437m
3	30+26.000	32+06.000	500m	6° 28' 02"	56.437m

07-FEB-2005 14:08
 R:\Projects\2552AA\2552AA.dwg
 R:\Projects\2552AA\2552AA.dwg