

NOTES

THE COST OF THE BARRIER RAIL ON THE APPROACH SLAB SHALL BE INCLUDED IN THE LUMP SUM CONTRACT PRICE BID FOR BRIDGE APPROACH SLABS.

APPROACH SLAB SHALL NOT BE CONSTRUCTED PRIOR TO COMPLETION OF THE BRIDGE DECK.

FOR REINFORCED BRIDGE APPROACH FILL INCLUDING FABRIC, IMPERMEABLE GEOMEMBRANE, 102mm Ø DRAINAGE PIPE, #78M STONE, AND SELECT MATERIAL, SEE ROADWAY PLANS.

TEMPORARY DRAINAGE AND TEMPORARY BERM AND SLOPE DRAINS WILL BE PAID FOR UNDER THE LUMP SUM PRICE FOR BRIDGE APPROACH SLAB.

AREA BETWEEN THE WINGWALL AND APPROACH SLAB SHALL BE GRADED TO DRAIN THE WATER AWAY FROM THE FILL FACE OF THE BRIDGE.

THE 150mm COMP. A.B.C. SHALL EXTEND 3m BEYOND THE END OF THE APPROACH SLAB AND 300mm OUTSIDE OF EACH EDGE OF THE SLAB.

THE CONTRACTOR MAY USE 100mm TYPE B-25.0B ASPHALT CONCRETE COURSE IN LIEU OF 150mm COMP. A.B.C. IF THIS OPTION IS USED, THE BASE COURSE SHALL EXTEND 300mm BEYOND THE END OF THE APPROACH SLAB AND THE WIDTH SHALL BE THE SAME AS THAT OF THE APPROACH SLAB.

THE CONTRACTOR MAY USE 125mm CLASS "A" CONCRETE BASE IN LIEU OF 150mm COMP. A.B.C. IF THIS OPTION IS USED, THE CONCRETE BASE SHALL EXTEND 300mm BEYOND THE END OF THE APPROACH SLAB AND THE WIDTH SHALL BE THE SAME AS THAT OF THE APPROACH SLAB. THE CONCRETE SHALL BE FINISHED TO A SMOOTH SURFACE AND A LAYER OF 13.6 kg. ROOFING FELT SHALL BE PLACED BETWEEN THE CONCRETE BASE AND THE APPROACH SLAB TO PREVENT BOND. THE APPROACH SLAB SHALL NOT BE CAST UNTIL THE CONCRETE BASE HAS REACHED AN AGE OF THREE CURING DAYS.

BILL OF MATERIAL

FOR ONE APPROACH SLAB (2 REQ'D)

BAR	NO.	SIZE	TYPE	LENGTH	WEIGHT
*A1	98	#16	STR	7520	1144
A2	100	#13	STR	7400	736
*B1	87	#19	STR	7180	1396
B2	87	#25	STR	7460	2579
*B3	2	#19	STR	3540	16
B4	2	#25	STR	3540	28
*B5	7	#16	STR	3560	39
*B6	7	#16	STR	3440	37
*B7	1	#16	3	2100	3
*B8	1	#16	3	1740	3
*S1	50	#16	STR	980	76
*S2	50	#16	1	1220	95
*S3	20	#16	2	680	21

REINFORCING STEEL	kg.	3343
*EPOXY COATED REINFORCING STEEL	kg.	2830

CLASS AA CONCRETE BREAKDOWN		
POUR 1 SLAB AND CURB	C. M.	31.3
POUR 2 RAIL	C. M.	1.6
CLASS AA CONCRETE	C. M.	32.9

BAR TYPES

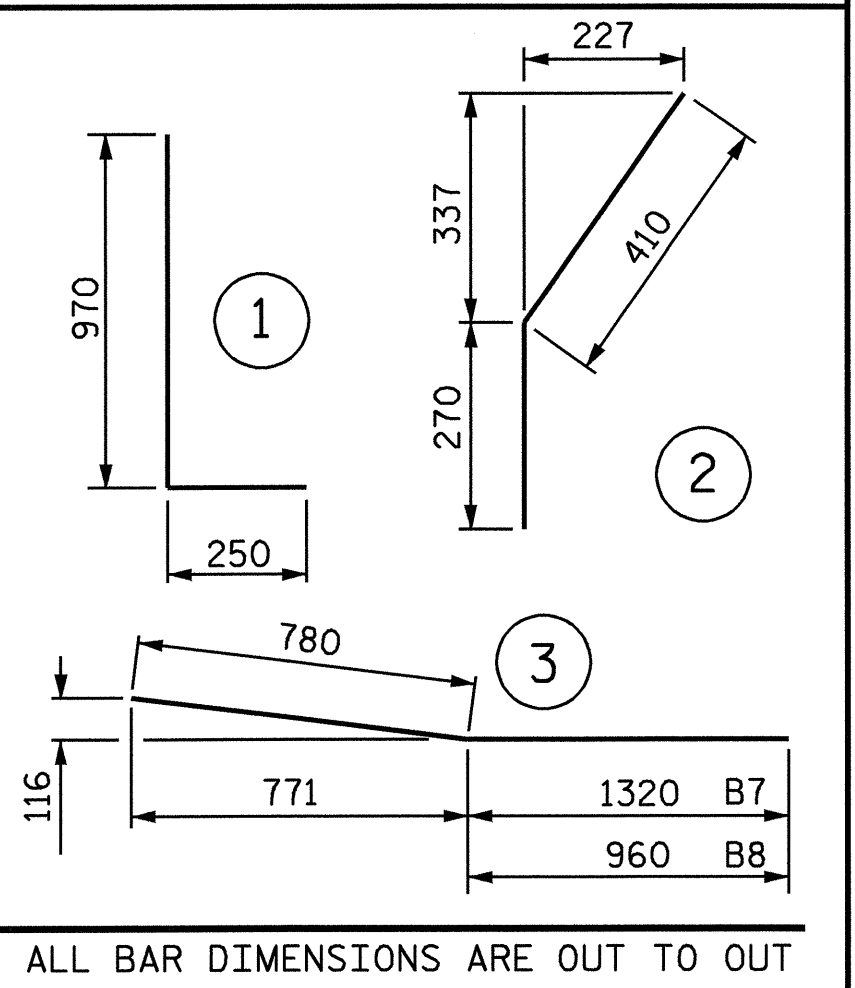

ALL BAR DIMENSIONS ARE OUT TO OUT

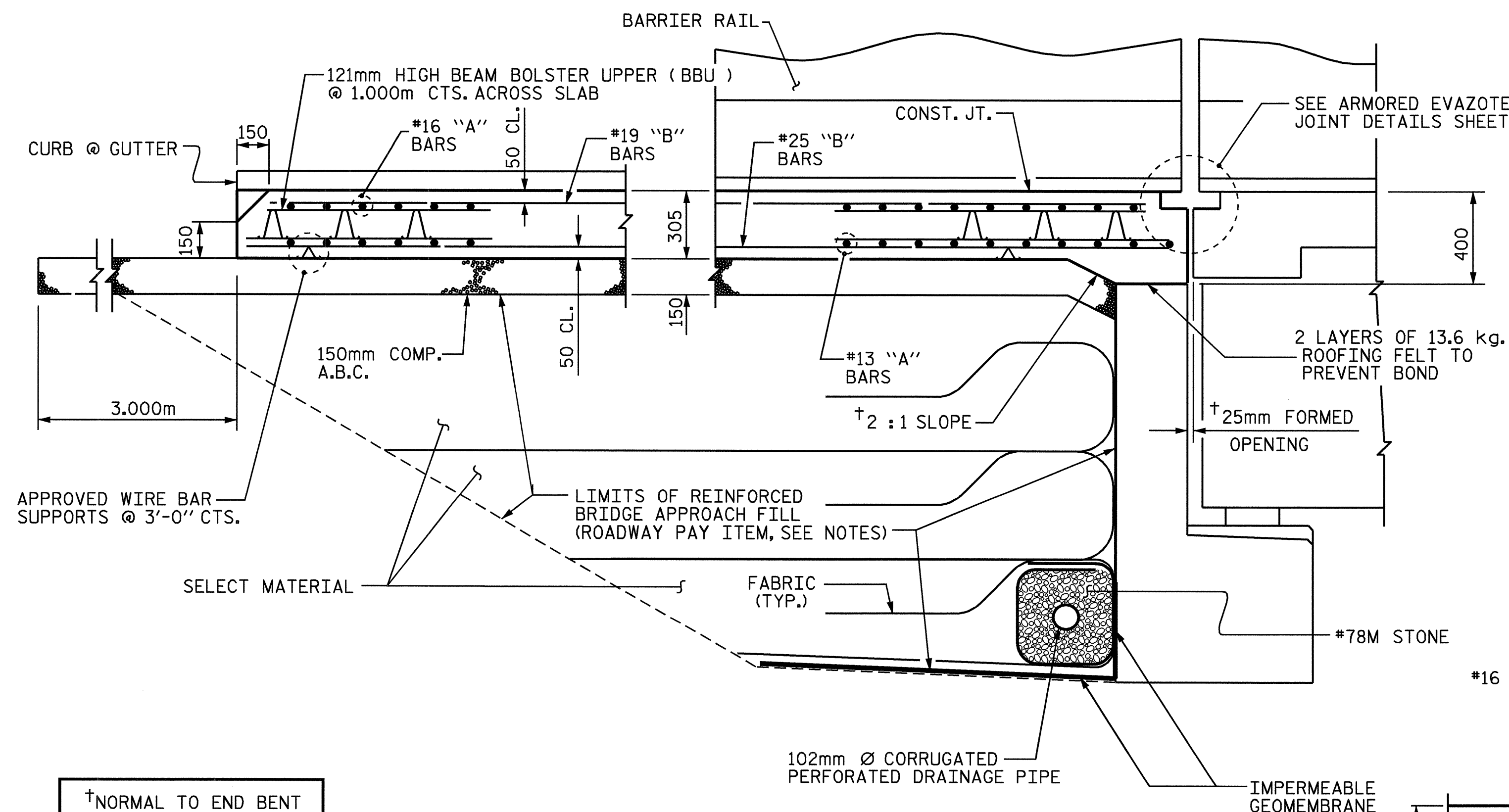

SECTION THRU SLAB

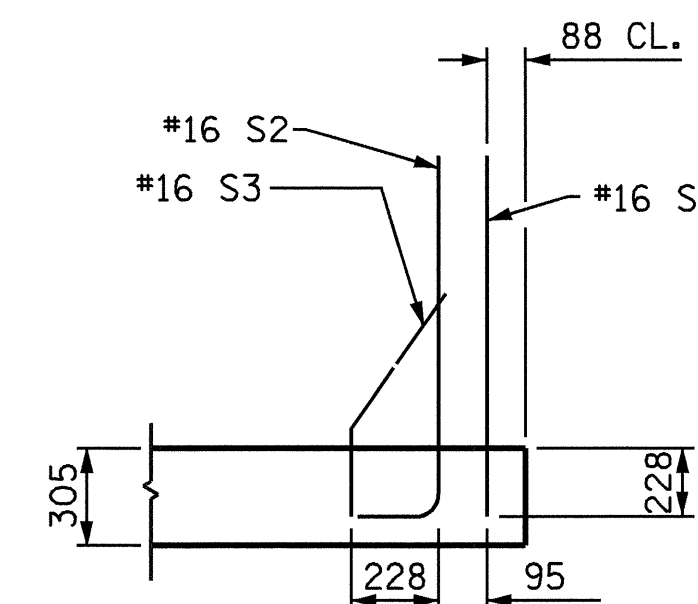

SECTION K-K

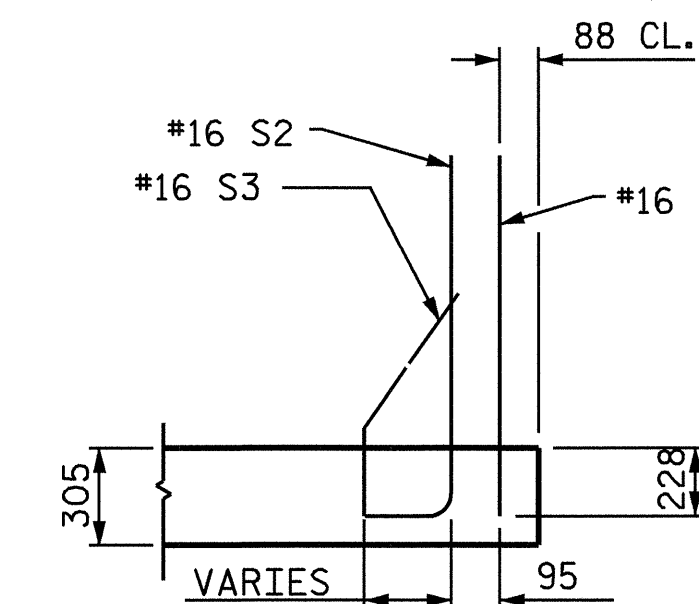

SECTION L-L

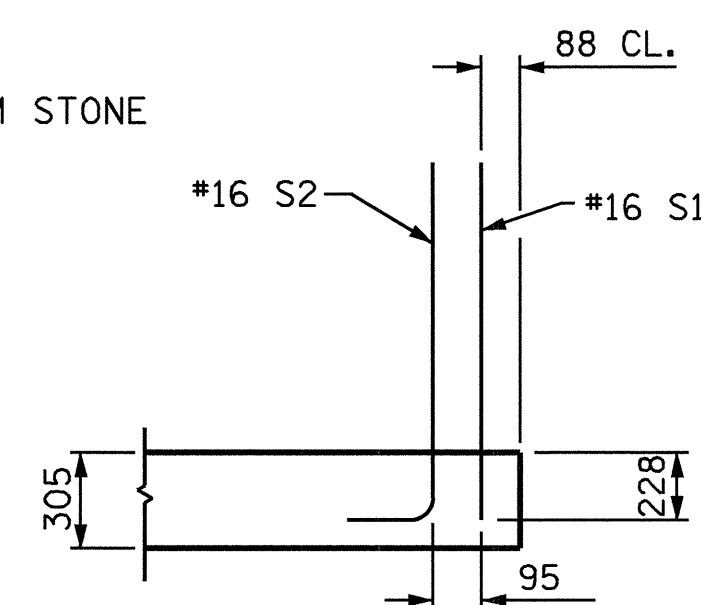

SECTION M-M

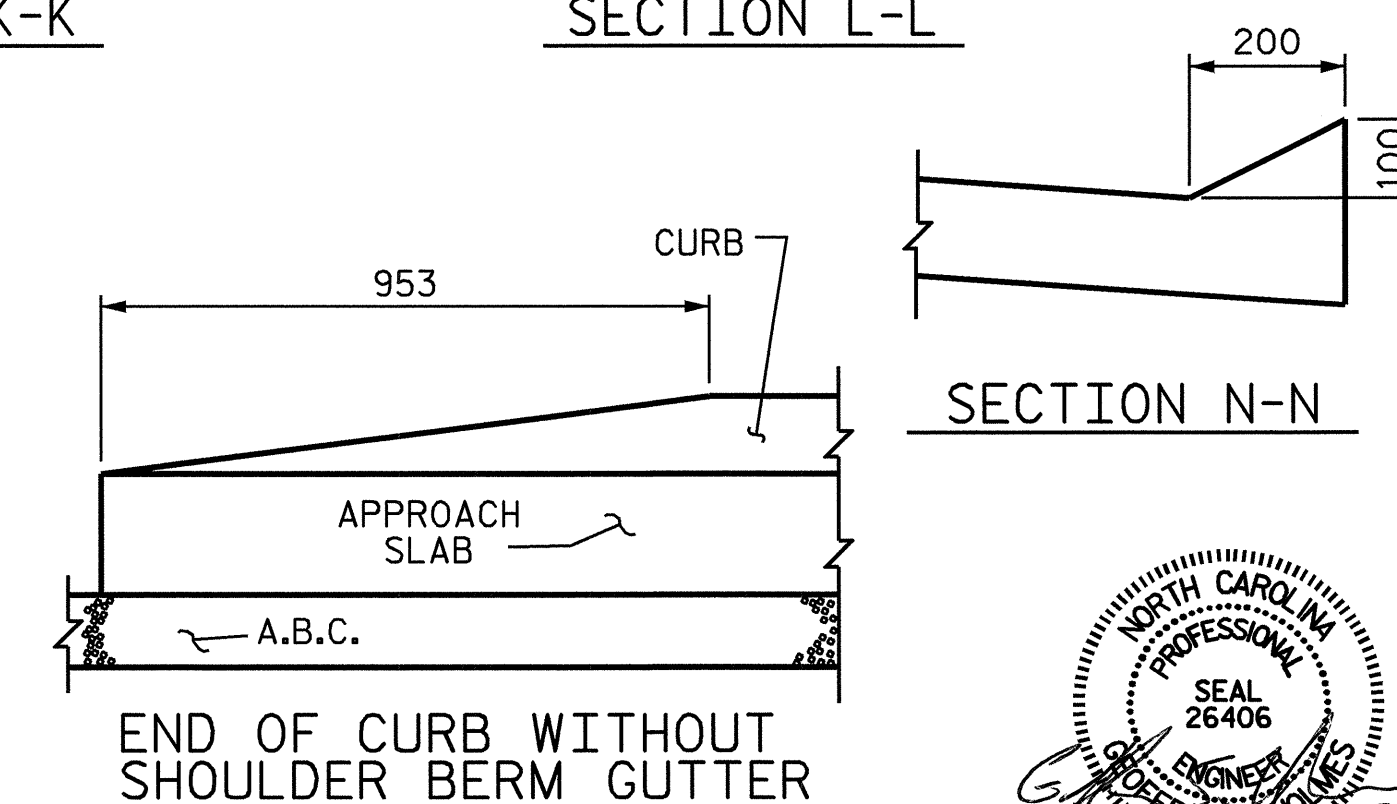

CURB DETAILS



PROJECT NO. R-2552 B

JOHNSTON COUNTY

STATION: 78+35.547-L-

12+97.374-Y10-

SHEET 2 OF 4

STATE OF NORTH CAROLINA
DEPARTMENT OF TRANSPORTATION
RALEIGH
STANDARD
BRIDGE APPROACH SLAB
FOR FLEXIBLE PAVEMENT
WITH BARRIER RAIL
(RIGHT LANE)

REVISIONS						SHEET NO.
NO.	BY:	DATE:	NO.	BY:	DATE:	5-77
1			3			TOTAL SHEETS 43
2			4			

STD. NO. BAS5SM

ASSEMBLED BY : R.D. MARTIN	DATE : 1-05
CHECKED BY : P.S. ERVIN	DATE : 2-05
DRAWN BY : RWW 8/01	ADDED 12/01
CHECKED BY : LES 8/01	REV. 5/7/03R RWW/JTE