

TYPICAL SECTION

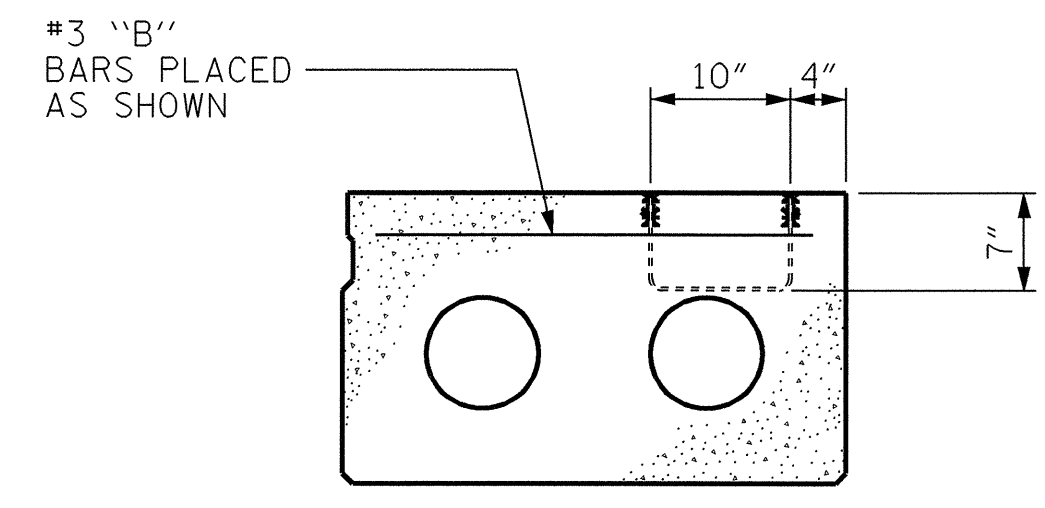

EXTERIOR SLAB SECTION

SHOWING PLACEMENT OF PRECAST ANCHORAGE ASSEMBLY IN CORED SLAB. (TYPE II UNIT SHOWN) (TYPE V UNIT SIMILAR EXCEPT LOCATION OF PRECAST ANCHORAGE ASSEMBLY IS MIRRORRED) INTERIOR TYPE III UNIT SIMILAR EXCEPT BOTH SIDES HAVE SHEAR KEYS. SEE "WOODEN RAIL" SHEETS FOR ADDITIONAL DETAILS AND RAIL POST SPACING.

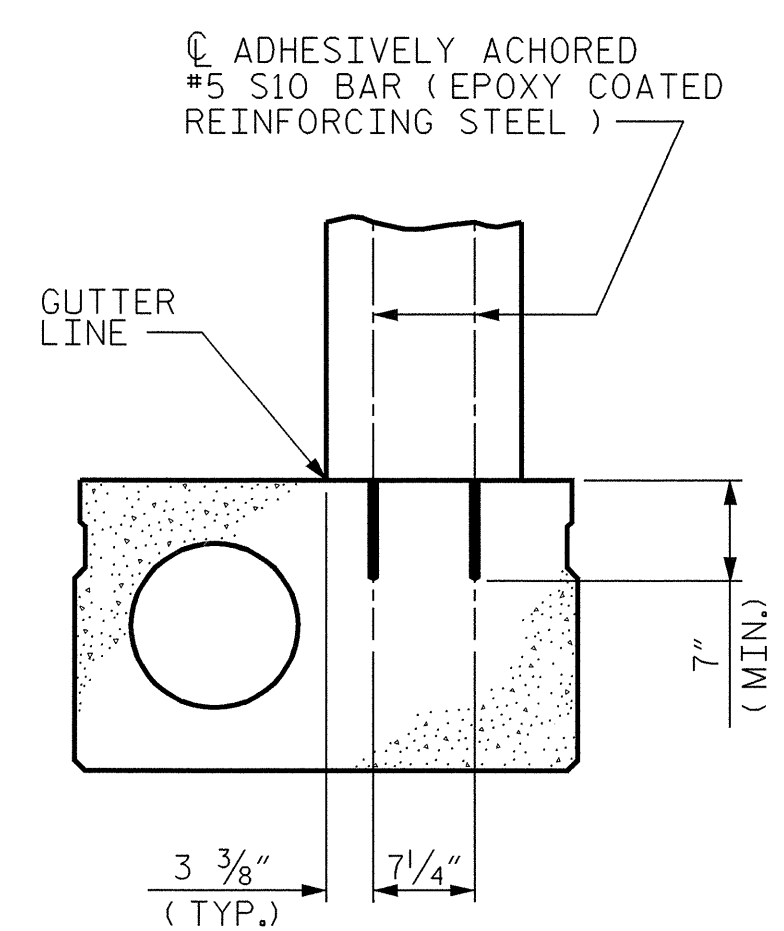

INTERIOR SLAB SECTION

SHOWING PLACEMENT OF #5 "S" BARS TO BE ADHESIVELY ANCHORED IN CORED SLAB. (TYPE IV UNIT) STRAND LAYOUT NOT SHOWN.

NOTE
 THE "TYPE" DESIGNATION FOR THE CORED SLAB UNITS REFERS TO THE SIZE OF THE CORED SLAB VOID AND THE TYPE OF RAIL ATTACHMENT, IF ANY. SEE DETAILS ON THIS SHEET AND SHEET 2 OF 3.

PROJECT NO. B-3445
CURRITUCK COUNTY
 STATION: 24+18.00 -L-

SHEET 1 OF 3

STATE OF NORTH CAROLINA
 DEPARTMENT OF TRANSPORTATION
 RALEIGH
 SUPERSTRUCTURE
 TYPICAL SECTIONS

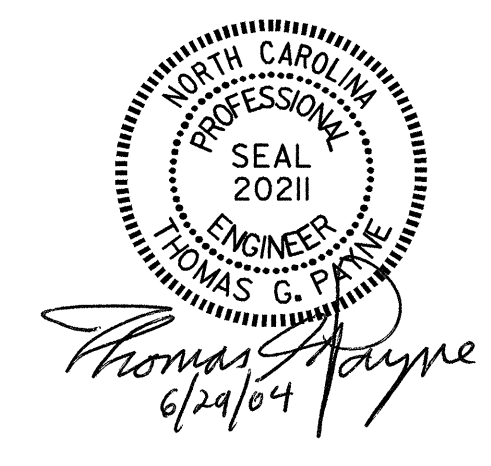

DRAWN BY : M. J. OSTRISHKO DATE : 11-20-01
 CHECKED BY : K. D. LAYNE DATE : 1-18-02

REVISIONS						SHEET NO.	
NO.	BY:	DATE:	NO.	BY:	DATE:	S-5	
1			3			TOTAL SHEETS	43
2			4				