

1/2" Ø LOW RELAXATION STRAND LAYOUT FOR INTERIOR SLAB SECTION

TYPE I UNIT & TYPE VI UNIT (TYPICAL SPANS A THRU C)

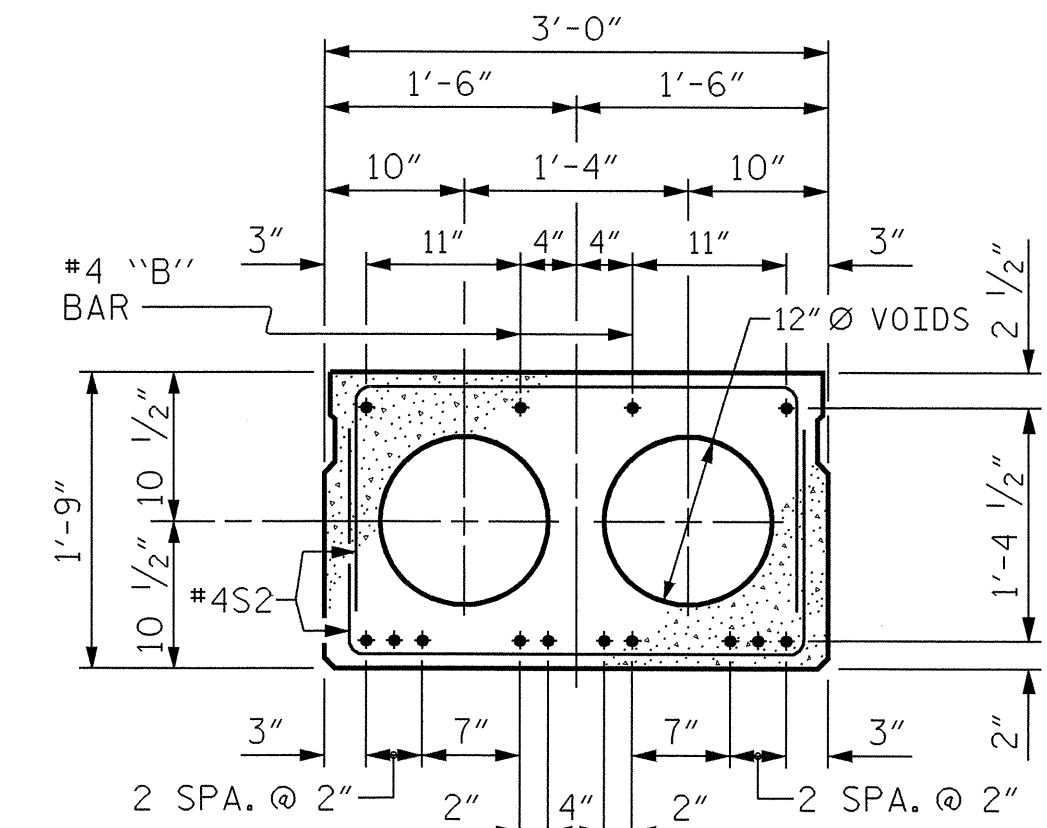

1/2" Ø LOW RELAXATION STRAND LAYOUT FOR INTERIOR SLAB SECTION

TYPE I UNIT & TYPE VI UNIT (TYPICAL SPAN D)

NOTE TO FABRICATOR: THE #4 "B" BARS IN TYPE II THRU TYPE V CORED SLAB UNITS ARE SPACED DIFFERENTLY THAN IN THE TYPE I AND VI CORED SLAB UNITS.

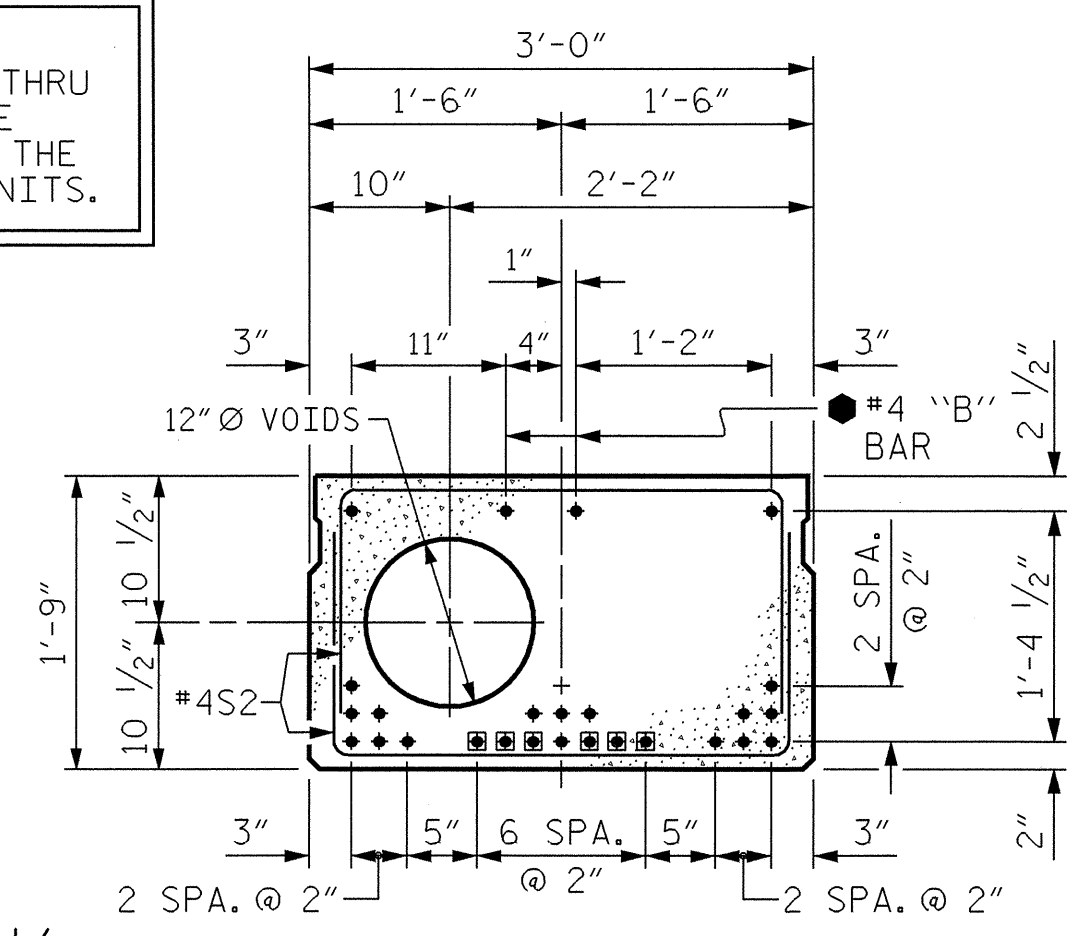

1/2" Ø LOW RELAXATION STRAND LAYOUT FOR INTERIOR SLAB SECTION

TYPE IV (TYPICAL SPANS A THRU C)

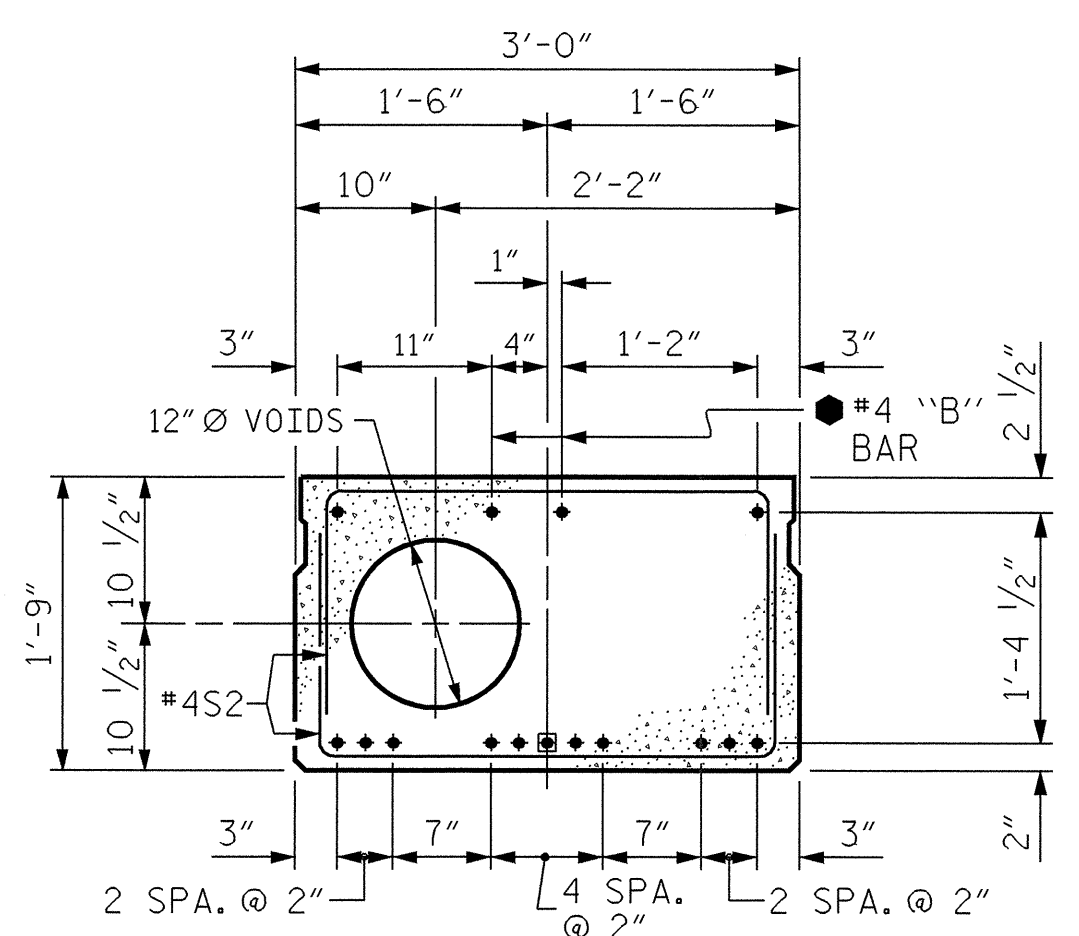

1/2" Ø LOW RELAXATION STRAND LAYOUT FOR INTERIOR SLAB SECTION

TYPE IV (TYPICAL SPAN D)

BOND SHALL BE BROKEN ON THESE STRANDS FOR A DISTANCE OF 4'-0" FROM END OF CORED SLAB UNIT. SEE STANDARD SPECIFICATIONS ARTICLE 1078-7.

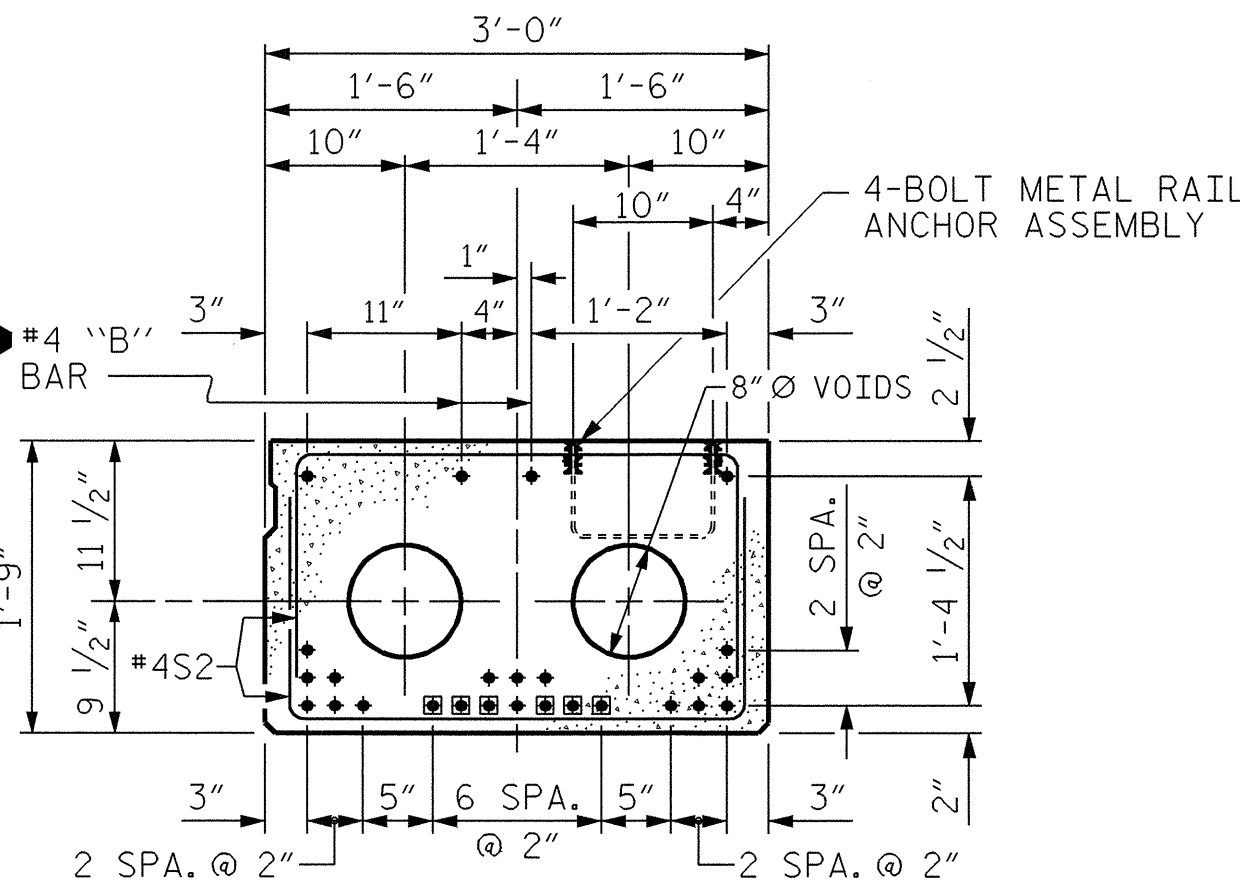

1/2" Ø LOW RELAXATION STRAND LAYOUT FOR EXTERIOR SLAB SECTION

TYPE II UNIT SHOWN, TYPE V UNIT SIMILAR (TYPICAL SPANS A THRU C) (FOR LOCATION OF ANCHORAGE ASSEMBLY, SEE "WOODEN RAIL" SHEETS.)

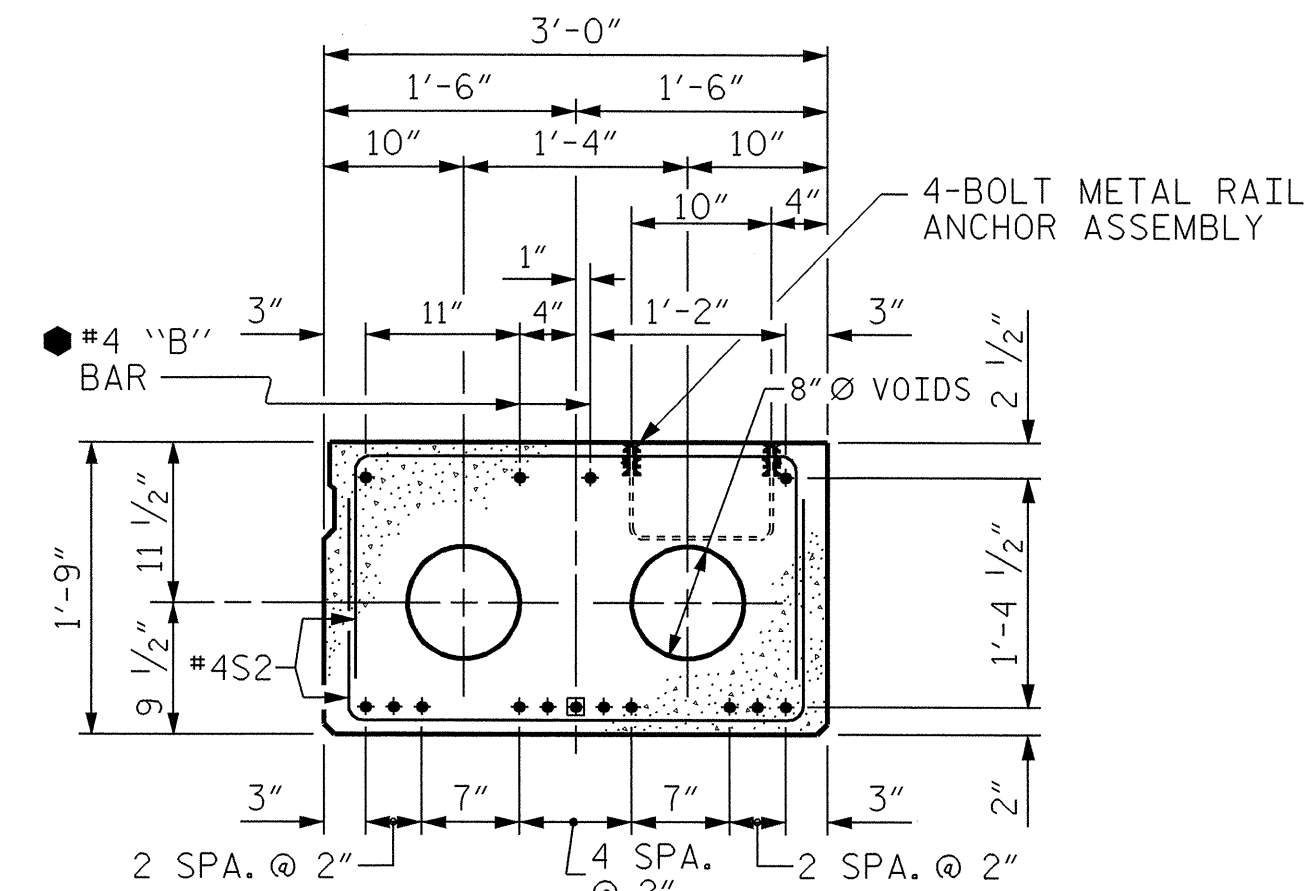

1/2" Ø LOW RELAXATION STRAND LAYOUT FOR EXTERIOR SLAB SECTION

TYPE II UNIT SHOWN, TYPE V UNIT SIMILAR (TYPICAL SPAN D) (FOR LOCATION OF ANCHORAGE ASSEMBLY, SEE "WOODEN RAIL" SHEETS.)

BOND SHALL BE BROKEN ON THESE STRANDS FOR A DISTANCE OF 4'-0" FROM END OF CORED SLAB UNIT. SEE STANDARD SPECIFICATIONS ARTICLE 1078-7.

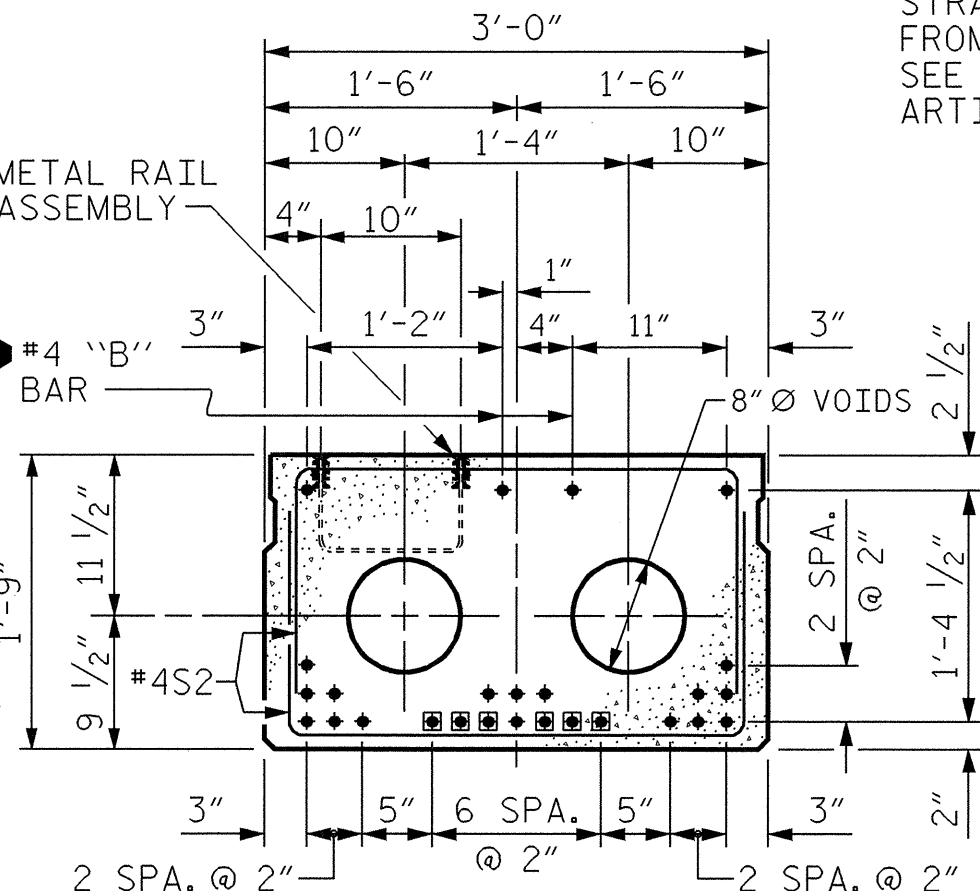

1/2" Ø LOW RELAXATION STRAND LAYOUT FOR INTERIOR SLAB SECTION

TYPE III UNIT (TYPICAL SPANS A THRU C) (FOR ANCHORAGE ASSEMBLY SEE "WOODEN RAIL".)

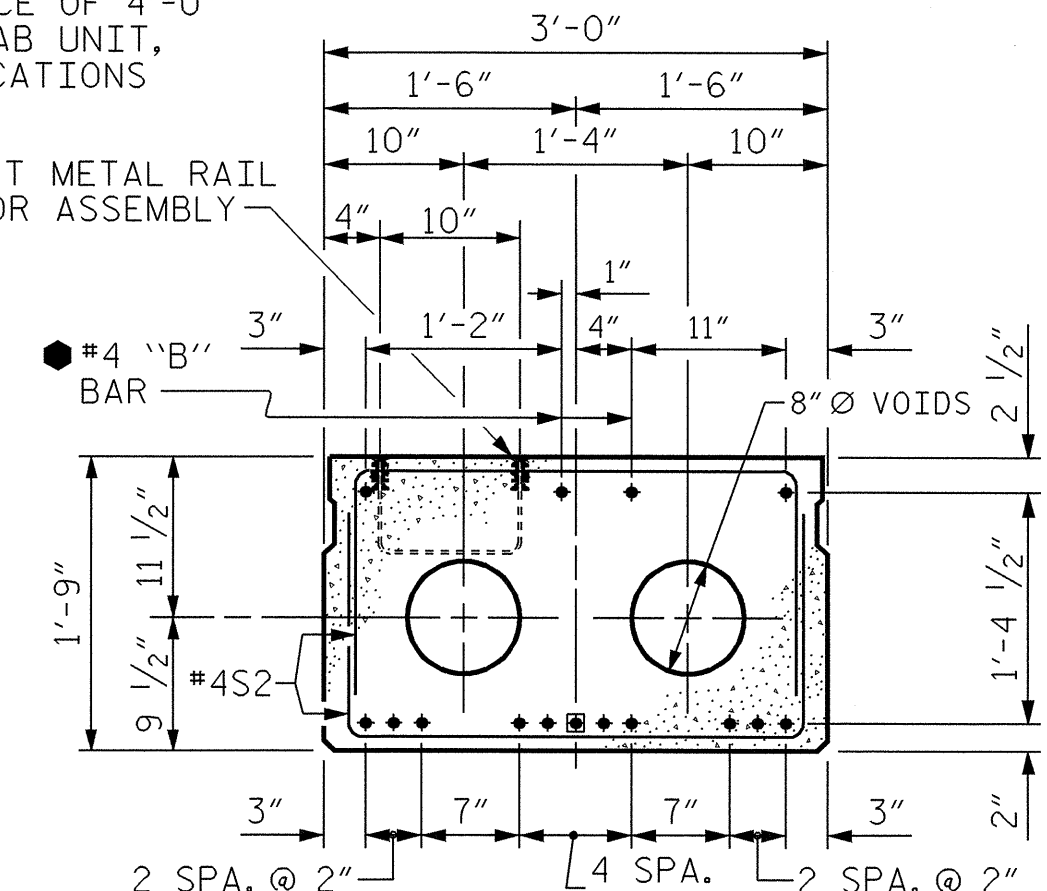

1/2" Ø LOW RELAXATION STRAND LAYOUT FOR INTERIOR SLAB SECTION

TYPE III UNIT (TYPICAL SPAN D) (FOR ANCHORAGE ASSEMBLY SEE "WOODEN RAIL".)

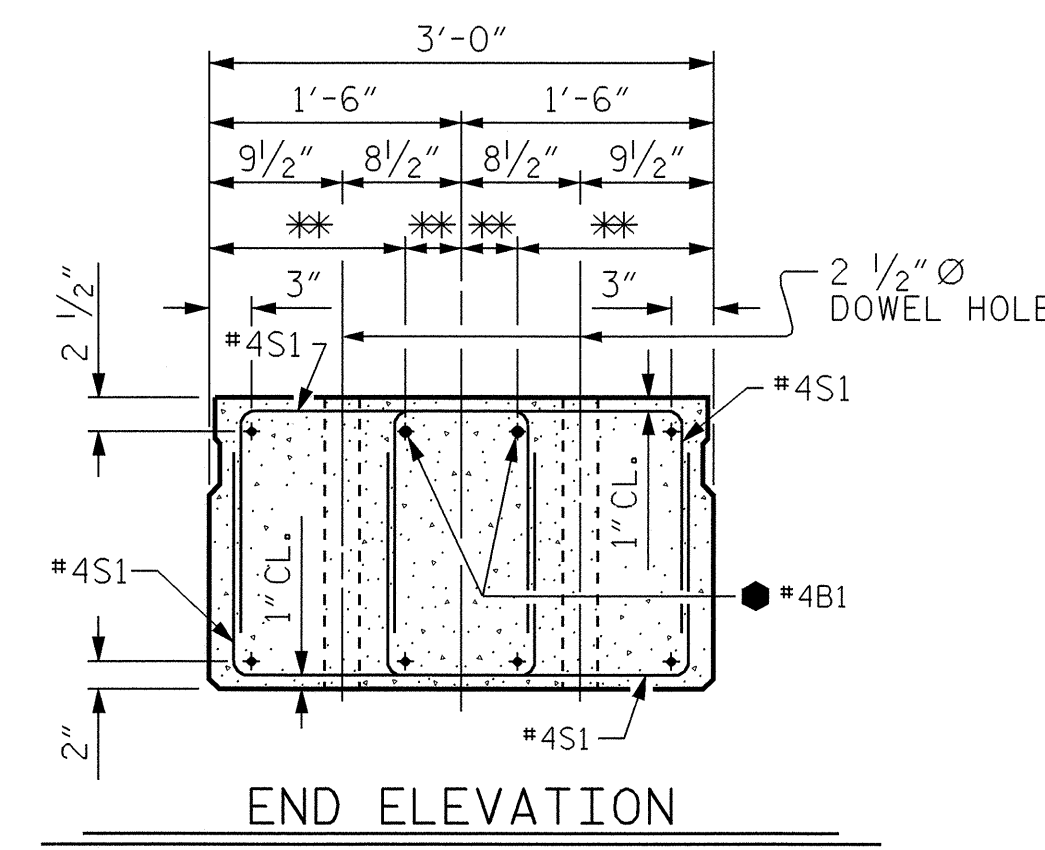

END ELEVATION SHOWING PLACEMENT OF DOUBLE STIRRUPS AND LOCATION OF DOWEL HOLES. STRAND LAYOUT NOT SHOWN. INTERIOR SLAB SECTION SHOWN-EXTERIOR SLAB SECTION SIMILAR EXCEPT FOR SHEAR KEY LOCATION. (\*\* = VARIES)

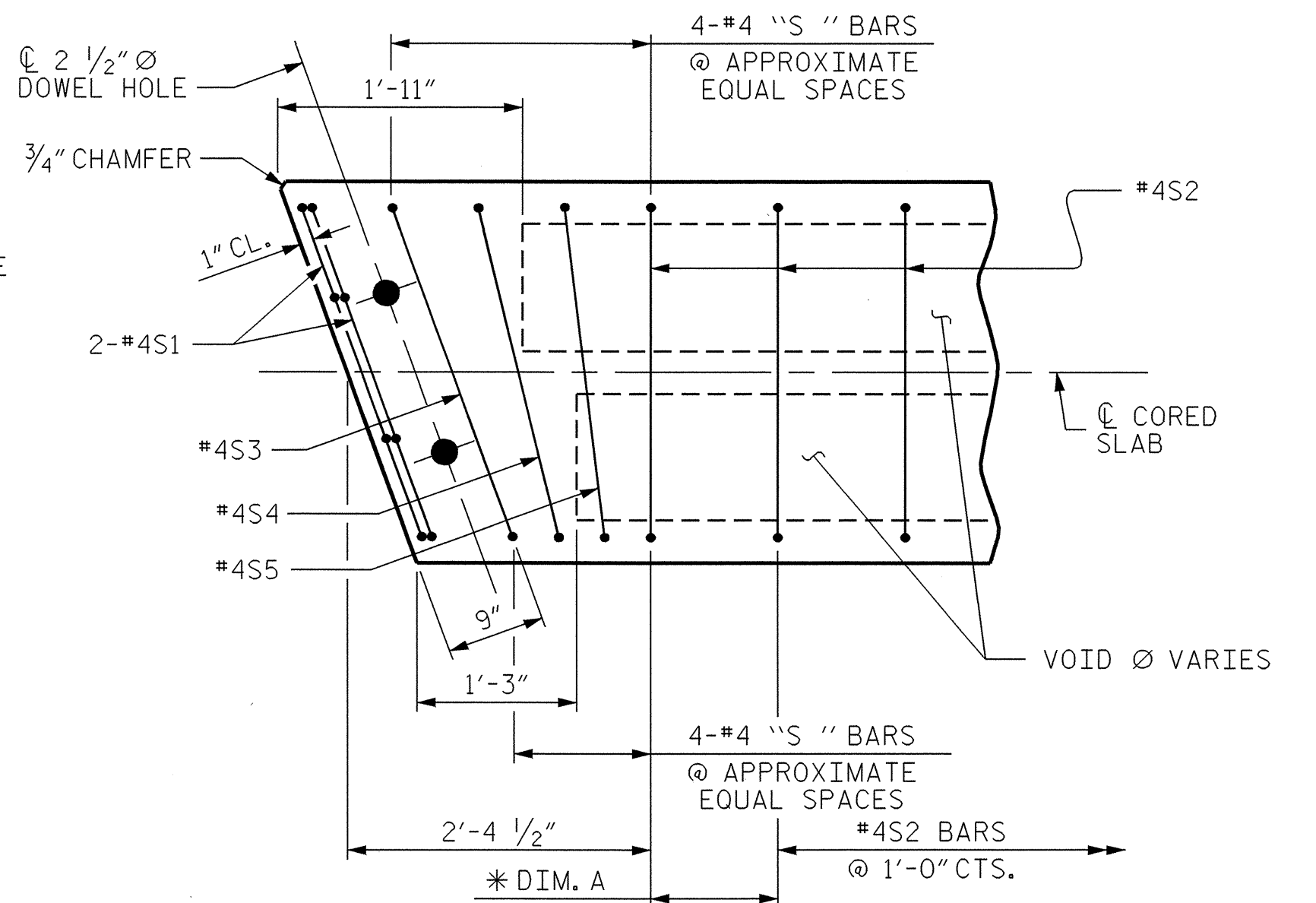

PART PLAN END OF CORED SLAB UNIT

NOTE: EXTERIOR SECTION SHOWN-INTERIOR SECTION SIMILAR. \* SEE "PLAN OF 3'-0" X 1'-9" CORED SLAB UNIT " SHEETS 1-3 FOR DIM. A.

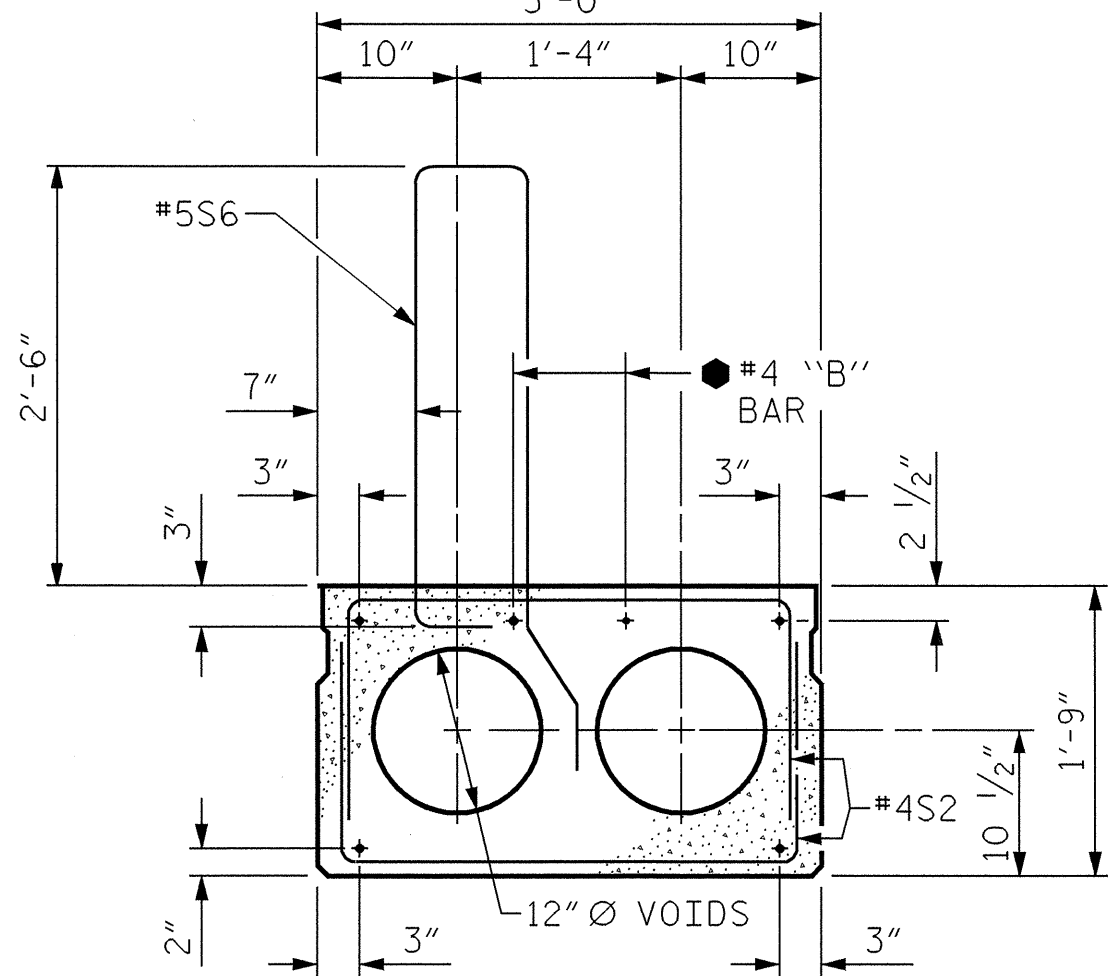

INTERIOR SLAB SECTION

FOR PRESTRESSED STRAND LAYOUT SEE INTERIOR SLAB SECTION, TYPE VI FOR SPANS A,B,C,& D.

PROJECT NO. B-3445  
CURRITUCK COUNTY  
STATION: 24+18.00 -L-  
SHEET 2 OF 3

STATE OF NORTH CAROLINA DEPARTMENT OF TRANSPORTATION RALEIGH						SHEET NO. S-6
SUPERSTRUCTURE TYPICAL SECTIONS						TOTAL SHEETS 43
REVISIONS						
NO.	BY:	DATE:	NO.	BY:	DATE:	
1			3			
2			4			

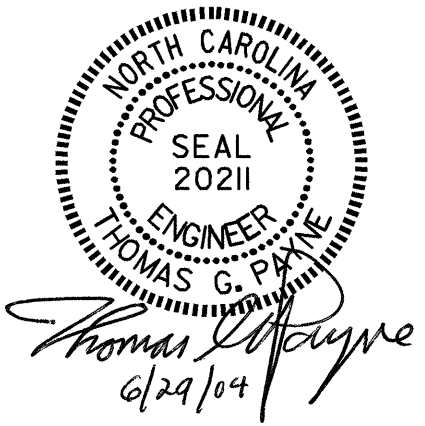

DRAWN BY: M. J. OSTRISHKO DATE: 11-20-01  
CHECKED BY: K. D. LAYNE DATE: 1-18-02

23-JUN-2004 16:37  
W:\squad1\B3445\finalplans\b344501cts.dgn  
klayne