

@ END BENT #1

@ END BENT #2

PLAN

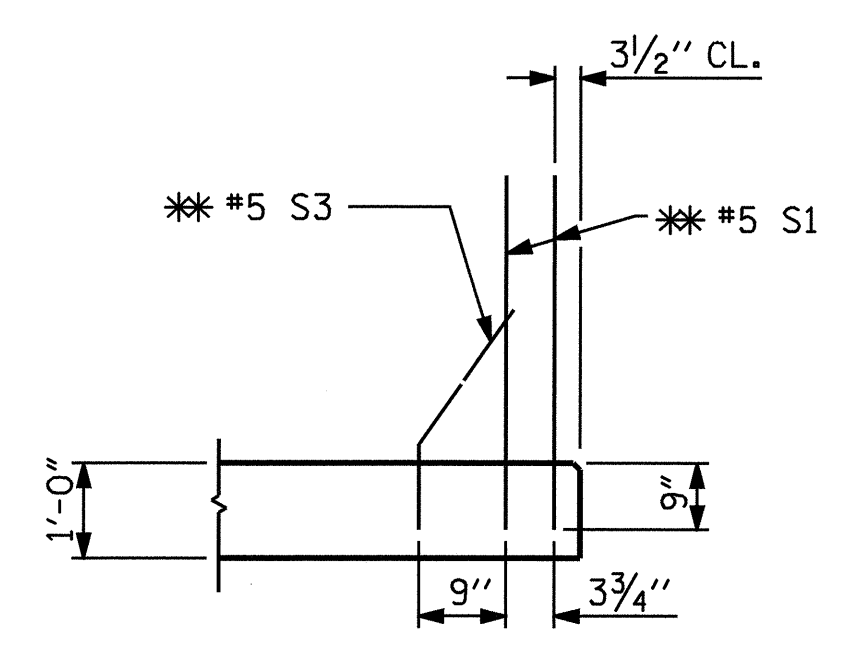

SECTION K-K  
\* ADHESIVELY ANCHORED

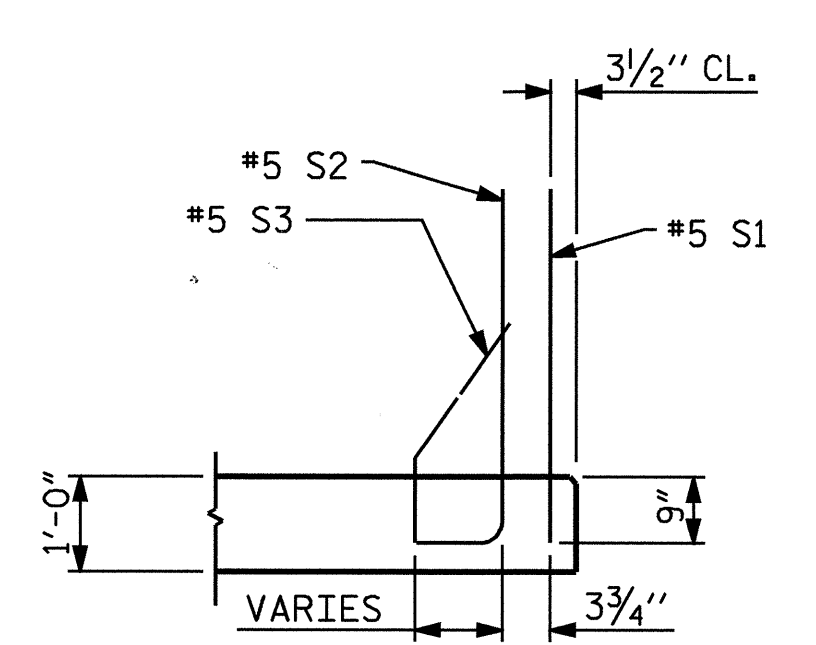

SECTION L-L

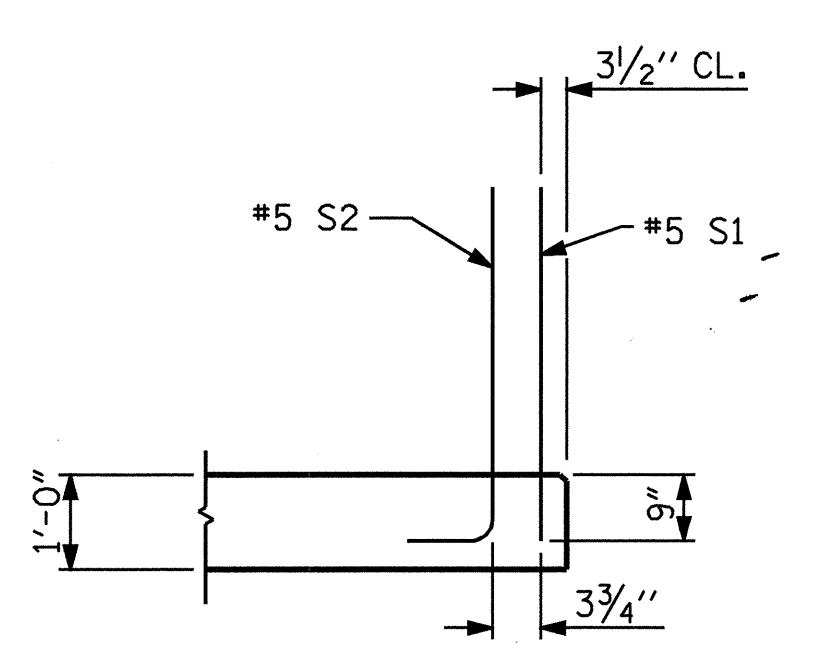

SECTION M-M

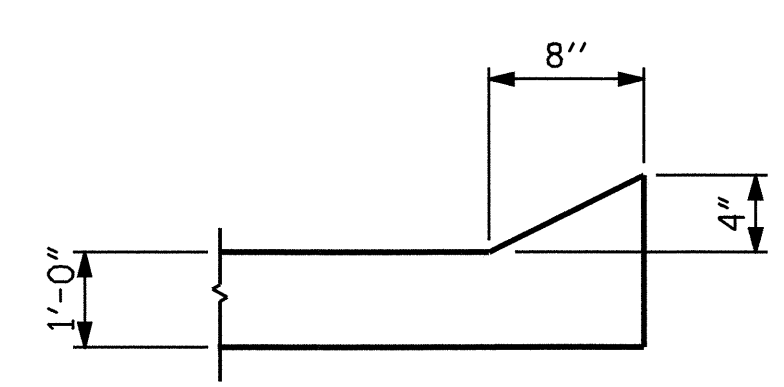

SECTION N-N

PROJECT NO. B-4327  
WILSON COUNTY  
 STATION: 23+80.00 -L-

SHEET 1 OF 4

STATE OF NORTH CAROLINA  
 DEPARTMENT OF TRANSPORTATION  
 RALEIGH

BRIDGE APPROACH SLAB  
 FOR FLEXIBLE PAVEMENT  
 WITH BARRIER RAIL

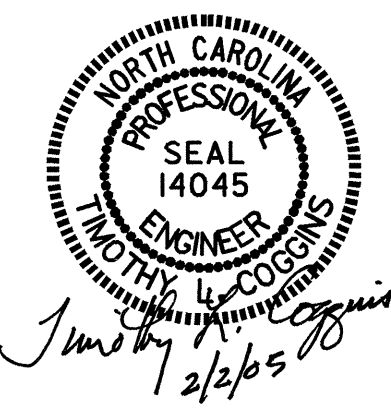

REVISIONS						SHEET NO.	
NO.	BY:	DATE:	NO.	BY:	DATE:	S-21	
1			3			TOTAL SHEETS	24
2			4				

DRAWN BY: PEGGY ADKINS DATE: 10-04  
 CHECKED BY: T. AVERETTE DATE: 10-04