

NOTES

STIRRUPS IN CAP MAY BE SHIFTED AS NECESSARY TO CLEAR DOWELS.

THE LATERAL GUIDE AT EACH END OF THE CAP IS NOT TO BE POURED UNTIL AFTER CORED SLAB UNITS ARE IN PLACE.

THE CONTRACTOR SHALL PROVIDE FOR INSTALLATION OF THE 4" Ø DRAIN PIPE THROUGH THE WING WALL AS REQUIRED FOR REINFORCED BRIDGE APPROACH FILLS, SEE THE ROADWAY PLANS. REINFORCING STEEL IN THE WING WALL MAY BE SHIFTED AS NECESSARY TO CLEAR THE DRAIN PIPE.

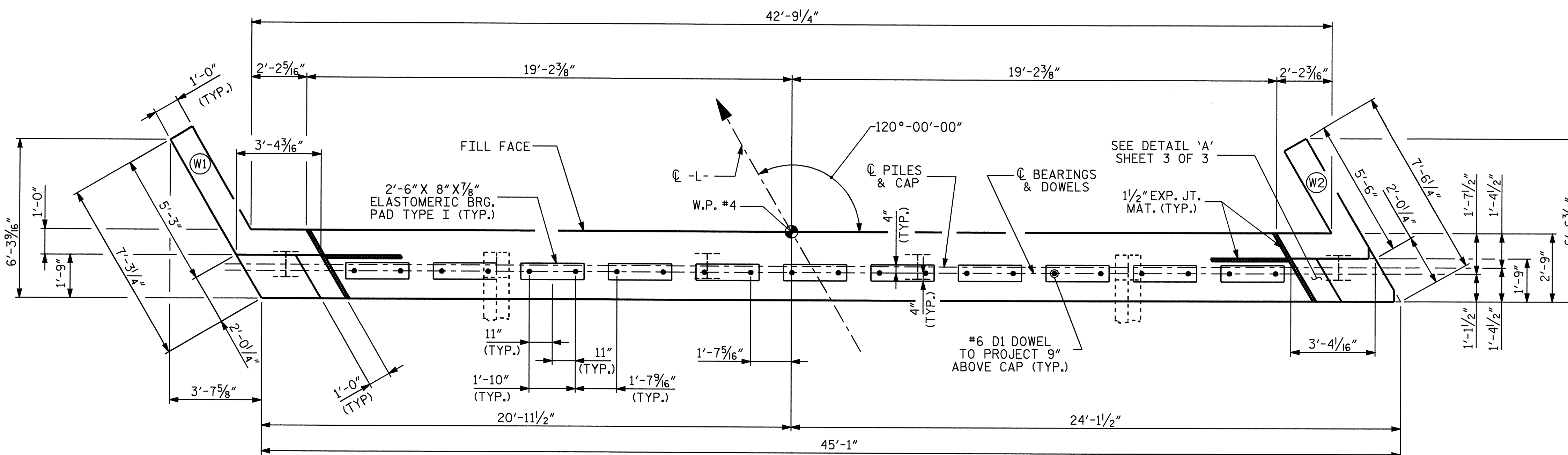

PLAN

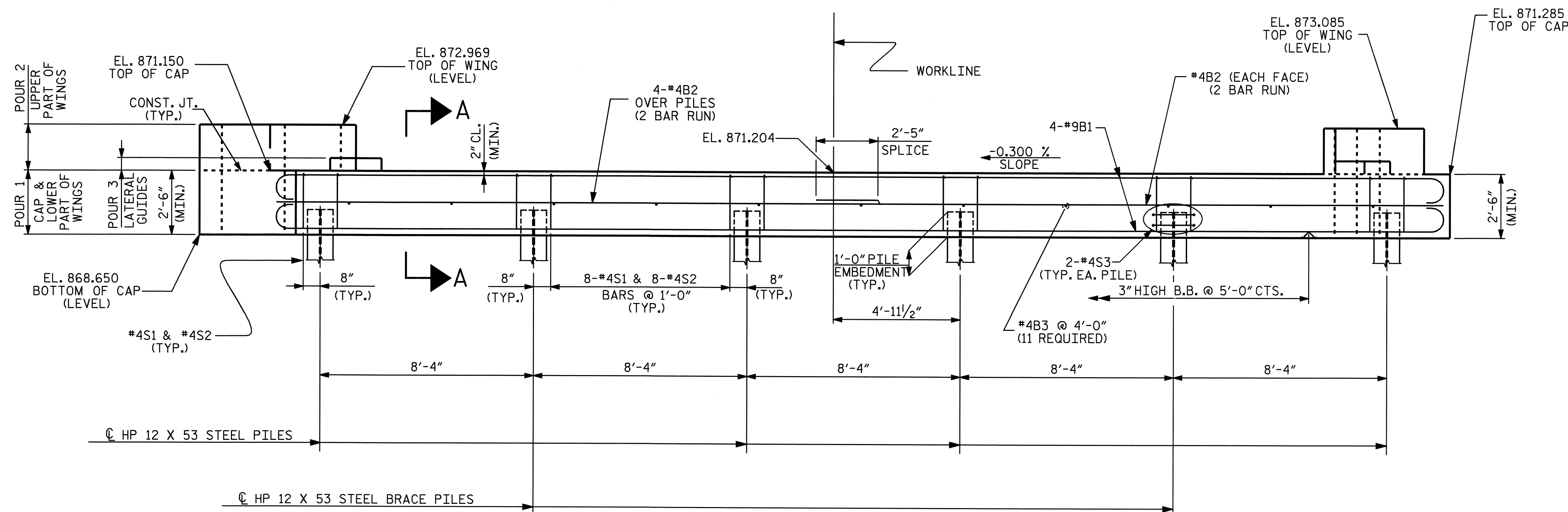

ELEVATION

PROJECT NO. B-4260
RUTHERFORD COUNTY
 STATION: 16+23.47-L-

SHEET 1 OF 3

STATE OF NORTH CAROLINA
 DEPARTMENT OF TRANSPORTATION
 RALEIGH

SUBSTRUCTURE
 END BENT #2

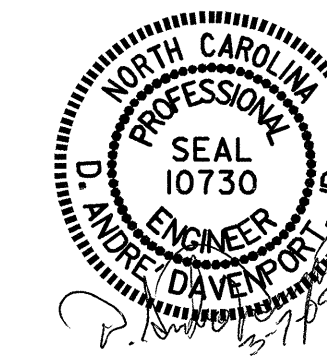

REVISIONS						SHEET NO.	
NO.	BY:	DATE:	NO.	BY:	DATE:	S-16	
1			3			TOTAL SHEETS 22	
2			4				

DRAWN BY : ADAM A COLE DATE : 6/29/04
 CHECKED BY : A. SORSENGINH DATE : 12/28/04

07-MAR-2005 07:05
 W:\sdcad\BASIS\B4260\acole\MICR052\B-42602.DGN
 adavenport

NCBDS