

PROJECT REFERENCE NO.	SHEET NO.
B-3450	EC-4/CONST.5
RW SHEET NO.	
ROADWAY DESIGN ENGINEER	HYDRAULICS ENGINEER

-DET2- CURVE DATA

<p>PI Sta 0+98.98 $\Delta = 29' 12'' 00.9''$ (LT) $D = 15' 04'' 40.2''$ $L = 193.66'$ $T = 98.98'$ $R = 380.00'$ SE = SEE PLANS RUNOFF = SEE PLANS $V = 35$ MPH</p>	<p>PI Sta 3+99.49 $\Delta = 56' 52'' 59.8''$ (RT) $D = 15' 04'' 40.2''$ $L = 377.26'$ $T = 205.82'$ $R = 380.00'$ SE = 0.06 RUNOFF = SEE PLANS $V = 35$ MPH</p>	<p>PI Sta 6+78.43 $\Delta = 31' 35'' 31.1''$ (LT) $D = 15' 04'' 40.2''$ $L = 209.53'$ $T = 107.50'$ $R = 380.00'$ SE = SEE PLANS RUNOFF = SEE PLANS $V = 35$ MPH</p>
---	---	--

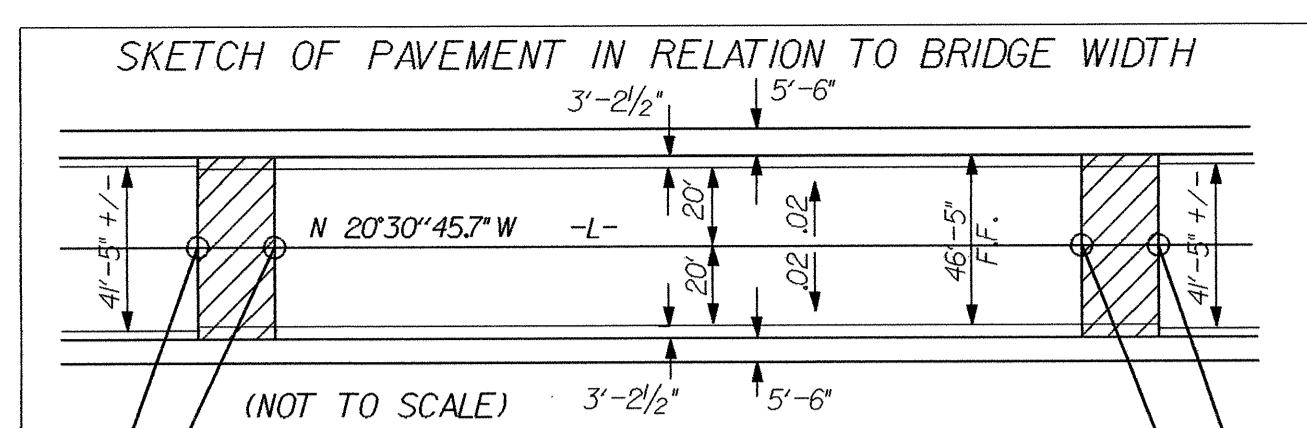

NOTE: UTILIZE TEMPORARY ROCK SEDIMENT DAM TYPE - B AS STILLING BASIN WHERE APPLICABLE.

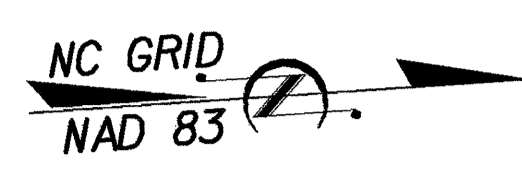

NOTE: PLACE TEMPORARY ROCK SEDIMENT DAMS TYPE-B AND TEMPORARY ROCK SILT CHECKS TYPE-A AT DRAINAGE OUTLETS.

CLEARING AND GRUBBING EROSION CONTROL FOR CONSTRUCTION SHEET 5

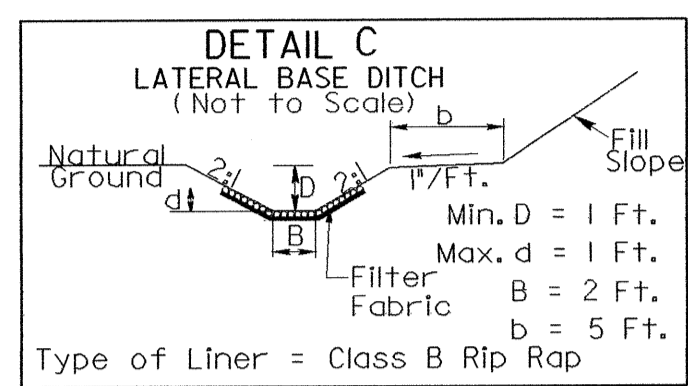

FROM STATION 21+00 TO STATION 21+50 LT.
 FROM STATION 22+85 TO STATION 23+40 LT.

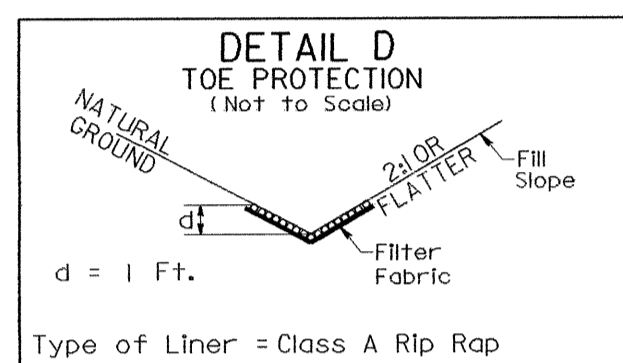

FROM STATION 19+25 TO STATION 21+00 LT.
 FROM STATION 23+40 TO STATION 25+20 LT.

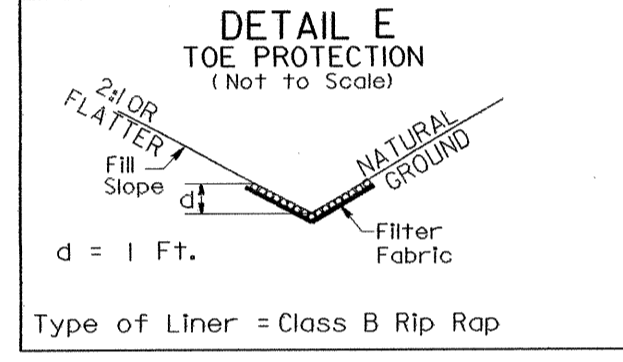

FROM STATION 20+85 TO STATION 21+80 RT.

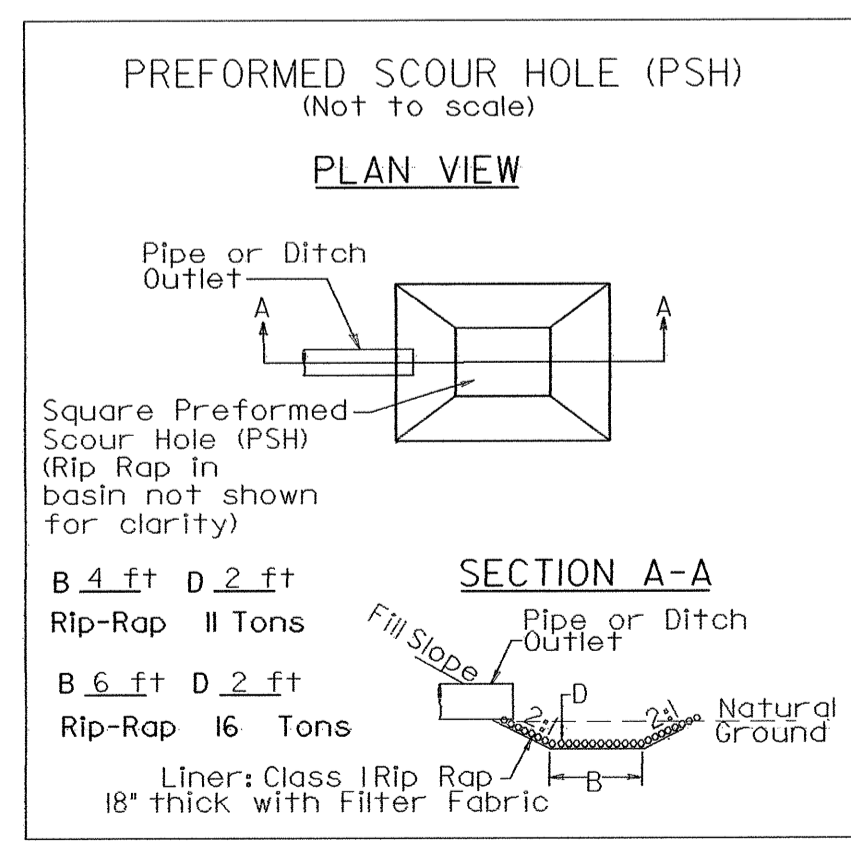
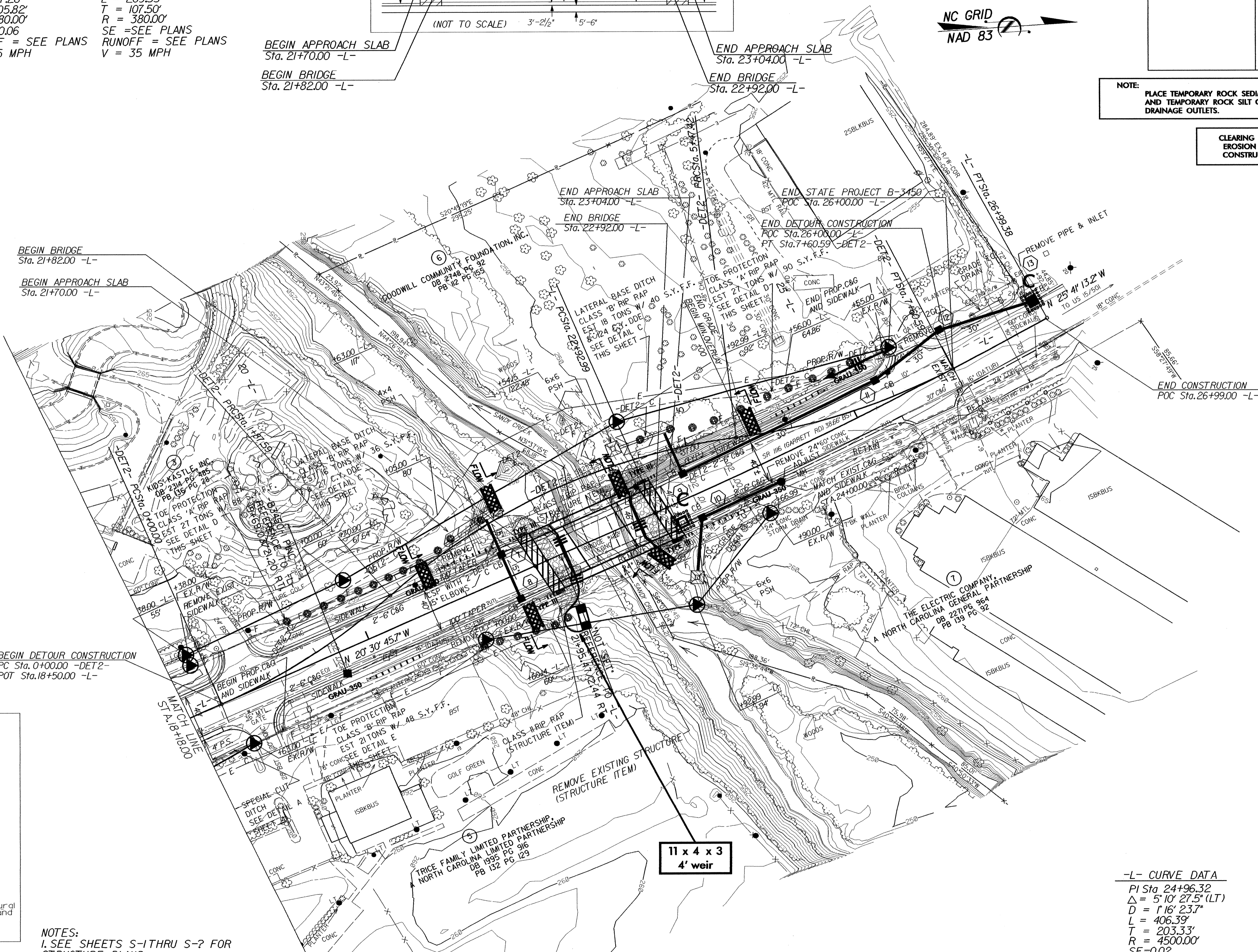

NOTES:
 1. SEE SHEETS S-1 THRU S-7 FOR STRUCTURE PLANS.
 2. SEE SHEET 6 FOR -L- GRADE & PROFILE & SHEET 7 FOR -DET2- GRADE & PROFILE.
 3. ALL PROPOSED DRIVEWAY RADII 25 FT UNLESS OTHERWISE SHOWN.
 4. FLAT GRATES TO BE USED ON ENTIRE PROJECT.

-L- CURVE DATA
 PI Sta 24+96.32
 $\Delta = 5' 10'' 27.5''$ (LT)
 $D = 1' 16'' 23.7''$
 $L = 406.39'$
 $T = 203.33'$
 $R = 4500.00'$
 SE = 0.02
 RUNOFF = SEE PLANS
 $V = 45$ MPH

11 x 4 x 3 4' weir
 DENOTES APPROACH SLAB