

PLAN

SPLICE LENGTH CHART		
BAR	SIZE	LENGTH
B3	#4	2'-5"

NOTES

THE LATERAL GUIDE AT EACH END OF THE CAP IS NOT TO BE POURED UNTIL AFTER THE CORED SLAB UNITS ARE IN PLACE.

STIRRUPS IN CAP MAY BE SHIFTED AS NECESSARY TO CLEAR DOWELS.

CONCRETE DISPLACED BY 12" PRESTRESSED CONCRETE PILES HAS BEEN DEDUCTED FROM THE CONCRETE QUANTITY.

THE CONTRACTOR, AT HIS OPTION, MAY SUBSTITUTE HP 12 x 53 STEEL PILES IN LIEU OF THE 12" PRESTRESSED CONCRETE PILES AT NO ADDITIONAL COST TO THE DEPARTMENT.

THE CONTRACTOR SHALL PROVIDE FOR INSTALLATION OF THE 4" DIAMETER DRAIN PIPE THROUGH THE WING WALL AS REQUIRED FOR REINFORCED BRIDGE APPROACH FILLS, SEE THE ROADWAY PLANS. REINFORCING STEEL IN THE WING WALL MAY BE SHIFTED AS NECESSARY TO CLEAR THE DRAIN PIPE.

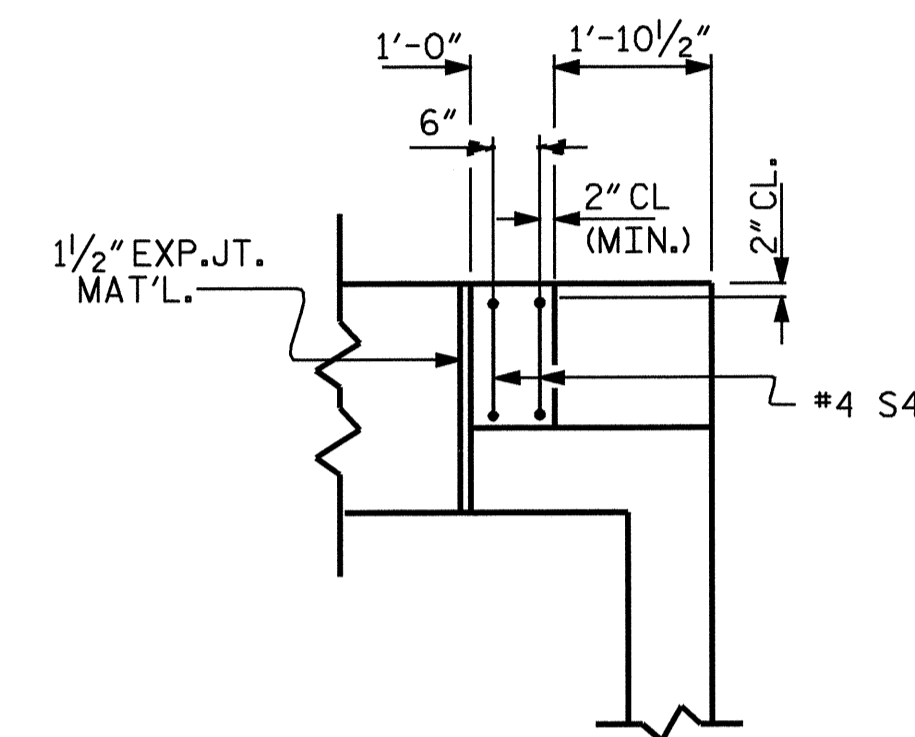

PLAN

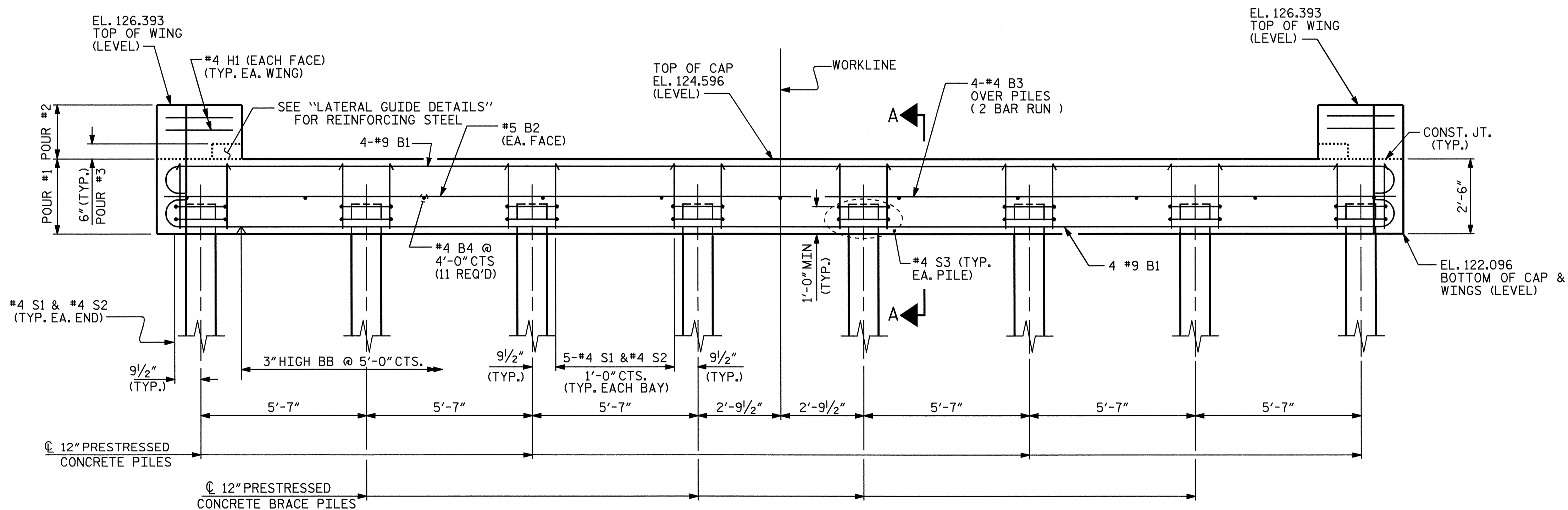

ELEVATION

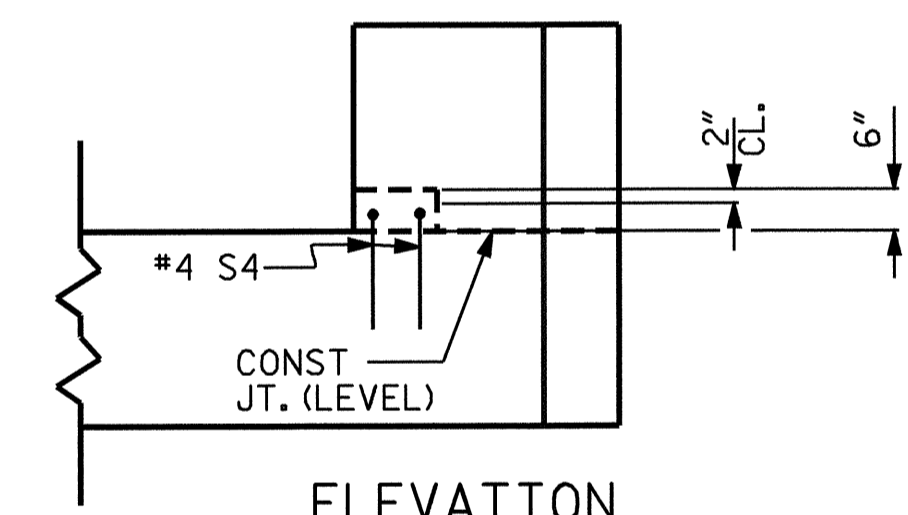

ELEVATION

LATERAL GUIDE DETAILS

(EACH END SIMILAR)

PROJECT NO. B-4248
 ROBESON COUNTY
 STATION: 16+67.50 -L-

SHEET 1 OF 2

STATE OF NORTH CAROLINA
 DEPARTMENT OF TRANSPORTATION
 RALEIGH

SUBSTRUCTURE
 END BENT 1

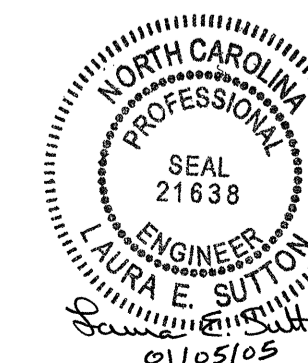

DRAWN BY : DJC/A.S. CALLAWAY DATE : 7-23-04
 CHECKED BY : L.E. SUTTON DATE : 11/30/04

22-DEC-2004 11:16
 W:\Squad\16-b4248\scallaway\B4248.sd.E*.01.dgn
 scallaway

REVISIONS						SHEET NO. S-12 TOTAL SHEETS 25
NO.	BY:	DATE:	NO.	BY:	DATE:	
1			3			
2			4			