

5/14/99

GATE DIMENSIONS IN INCHES

SIZE DIA.	B	C	D	F	G	H	J	K	L°	M	N
4	2 1/4	6 5/16	8 1/2	3/8	4 1/8	2 1/4	5 1/8	5 5/8	5	1 1/2	1 3/8
6	2 3/16	8 1/16	10	3/8	4 1/8	2 1/4	7 1/8	7 9/16	5	1 1/2	1 3/8
8	3 1/2	10	12	3/8	4 1/4	2 3/16	9 1/8	9 5/8	5	1 1/2	1 3/8
10	4 3/4	12 1/4	14 1/2	3/8	4 1/2	2 1/4	11 3/16	11 5/8	5	1 1/2	1 3/8
12	5 1/8	15	17 1/8	3/8	4 1/2	2 1/8	13 1/8	13 5/8	5	1 1/2	1 3/8
14	5 5/16	16 7/8	19 5/8	3/8	4 3/4	2 1/8	15 1/16	15 5/8	5	1 1/2	1 3/8
15	6 1/4	18 1/8	20	3/8	5	2 1/4	16	16 3/4	5	1 1/2	1 3/8
16	6 5/8	18 11/16	21 5/8	7/16	5	2 3/8	17	17 3/4	5	1 1/2	1 3/8
18	7 7/16	21	24 3/8	7/16	5 3/8	2 1/8	19	19 3/4	5	1 1/2	1 3/8
20	8 1/4	23 3/16	26 1/2	1 1/2	6	2 1/4	21 1/8	21 3/4	5	5/8	1 5/8
21	8 3/16	24 1/8	27 1/2	1 1/2	7	2 1/4	22	22 3/4	5	5/8	1 5/8
24	9 1/16	27 1/2	32	1 1/2	7 5/8	2 1/4	25	26 1/2	5	5/8	1 5/8
30	12	34	39 5/8	3/4	6 1/2	2 3/16	31	32	2 1/2	3/4	2
36	14 3/8	40 5/8	46	3/4	8	2 1/8	37	38	2 1/2	3/4	2
42	16 1/16	47 3/8	55 3/4	3/4	8	2 1/2	43 1/8	44 1/8	2 1/2	3/4	2
48	19 5/16	54 1/2	63 3/8	3/4	9 1/8	3	49 7/8	51	2 1/2	3/4	2
54	22 1/8	60 1/4	71	7/8	9 3/4	3	55 1/4	57	2 1/2	1	2 3/4
60	24 3/16	72	80 5/8	1	10 3/4	3	61 1/4	62 3/4	2 1/2	1	2 3/4
72	29	83	95 1/2	1 1/8	11 1/2	3 1/8	74 3/4	76 1/2	2 1/2	1	2 3/4

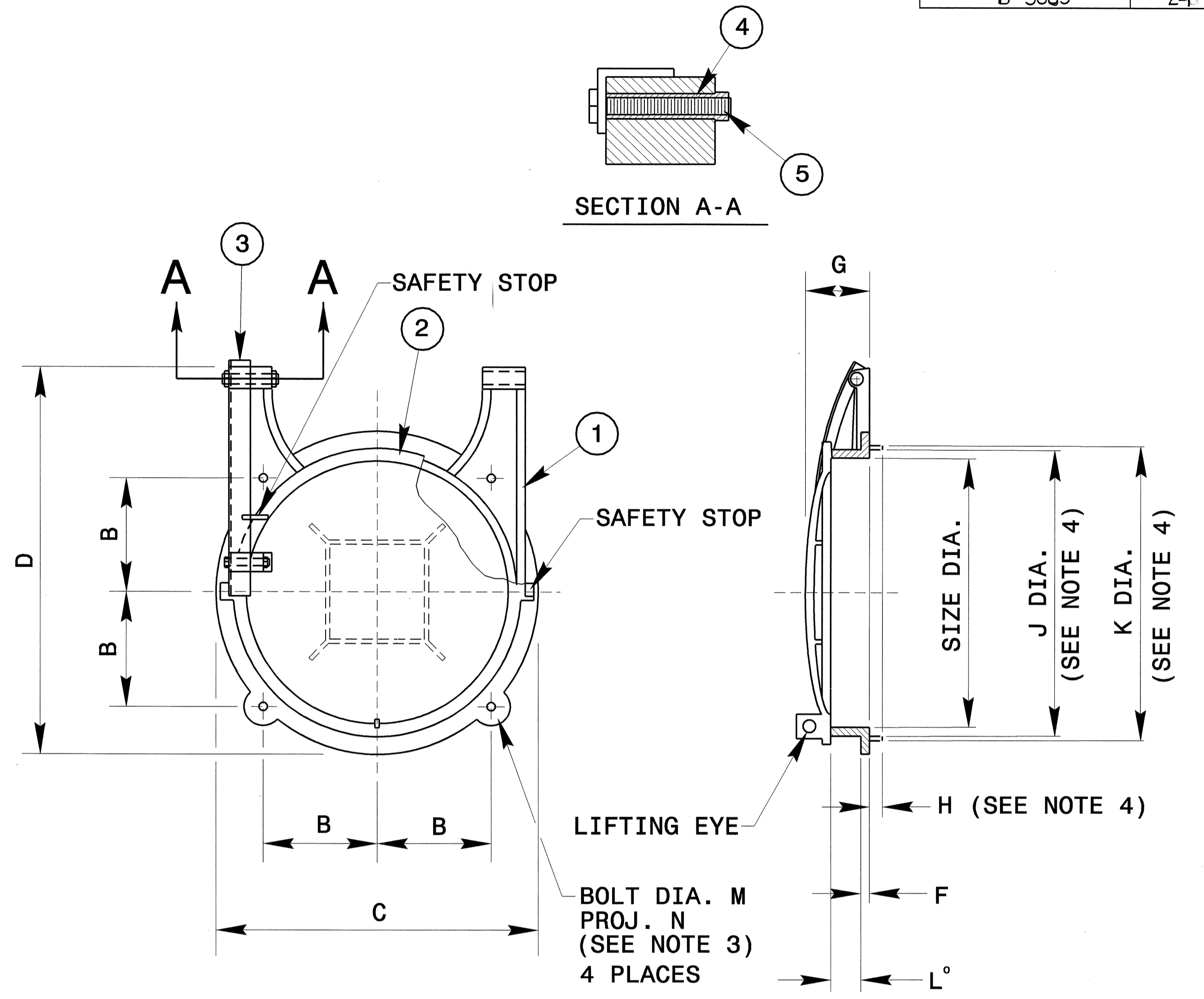

- NOTES:**
- FOR USE WITH SEATING HEADS TO 10 FEET.
 - NOT RECOMMENDED FOR PUMP DISCHARGE USE.
 - ADD GROUT PAD THICKNESS TO ANCHOR BOLT PROJECTION.
 - APPLIES TO SPIGOT BACK GATE ONLY. SPIGOT, SHOWN IN PHANTOM, IS OPTIONAL.
 - INSTALL AS DIRECTED BY THE ENGINEER.

- FRAME
- COVER
- HINGE LINK
- HINGE BUSHING
- HINGE BOLT & NUT

18-FEB-2004 07:30
W:\Special\Detail\english\b3685_flap_gate.dgn
RNB:ttt AT DS203039

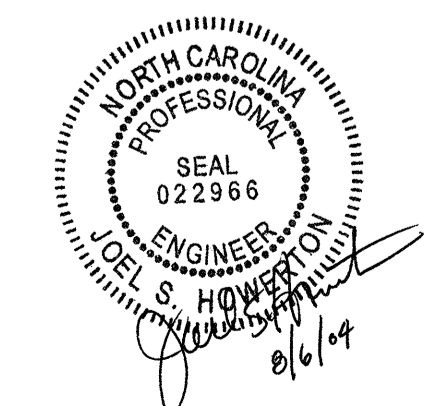

**DESIGN SERVICES UNIT
STANDARDS AND SPECIAL DESIGN**
Office 919-250-4128 FAX 919-250-4119

FLAP GATE DETAIL

ORIGINAL BY: rnbritt	DATE: 2-17-04
MODIFIED BY: rnbritt	DATE: 2-20-04
CHECKED BY: C.B. Venn	DATE: 2-20-04
FILE SPEC.: details\english\b3685flapgate.dgn	