

PLAN

NOTES

- STIRRUPS IN CAP MAY BE SHIFTED AS NECESSARY TO CLEAR DOWELS.
- THE LATERAL GUIDE AT EACH END OF THE CAP IS NOT TO BE POURED UNTIL AFTER CORED SLAB UNITS ARE IN PLACE.
- THE STEEL PILES SHALL BE GALVANIZED IN ACCORDANCE WITH SECTION 1076 OF THE STANDARD SPECIFICATIONS. FOR GALVANIZING STEEL PILES, SEE SPECIAL PROVISIONS.

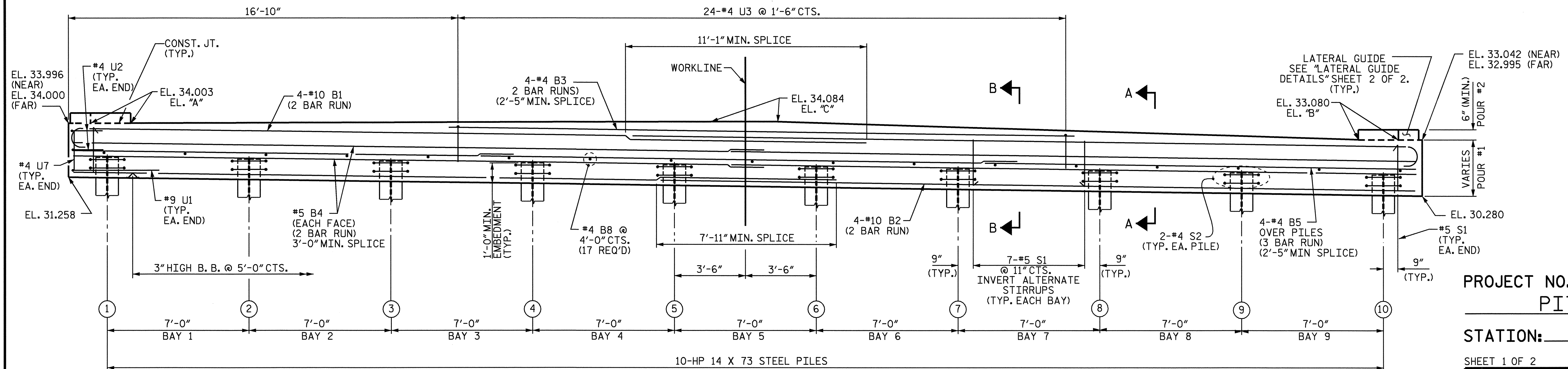

ELEVATION

TOP OF PILE ELEVATIONS	
1	32.236
2	32.134
3	32.032
4	31.930
5	31.828
6	31.726
7	31.624
8	31.522
9	31.420
10	31.314

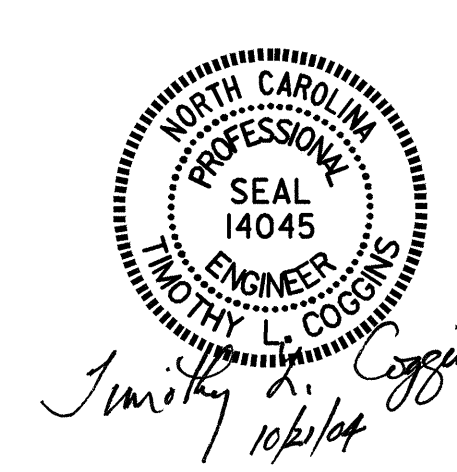

PROJECT NO. B3685  
 PITT COUNTY  
 STATION: 17+47.50 -L-

SHEET 1 OF 2

STATE OF NORTH CAROLINA DEPARTMENT OF TRANSPORTATION RALEIGH					
SUBSTRUCTURE BENT #2					
REVISIONS					SHEET NO.
NO.	BY:	DATE:	NO.	BY:	DATE:
1			3		
2			4		
					TOTAL SHEETS
					27

DRAWN BY: PEGGY ADKINS DATE: 7/04  
 CHECKED BY: T. L. AVERETTE DATE: 8-04