

19-OCT-2004 14:42
 W:\Special Details\erlewerd\stds\02\Std to Special Details\english\862d03.dgn
 erlewerd At 05/21/04

STATE OF
 NORTH CAROLINA
 DEPT. OF TRANSPORTATION
 DIVISION OF HIGHWAYS
 RALEIGH, N.C.

ENGLISH DETAIL DRAWING FOR
STRUCTURE ANCHOR UNITS
 ANCHORAGE FOR GUARDRAIL POST ON BOX CULVERT

SHEET 1 OF 4
862D03

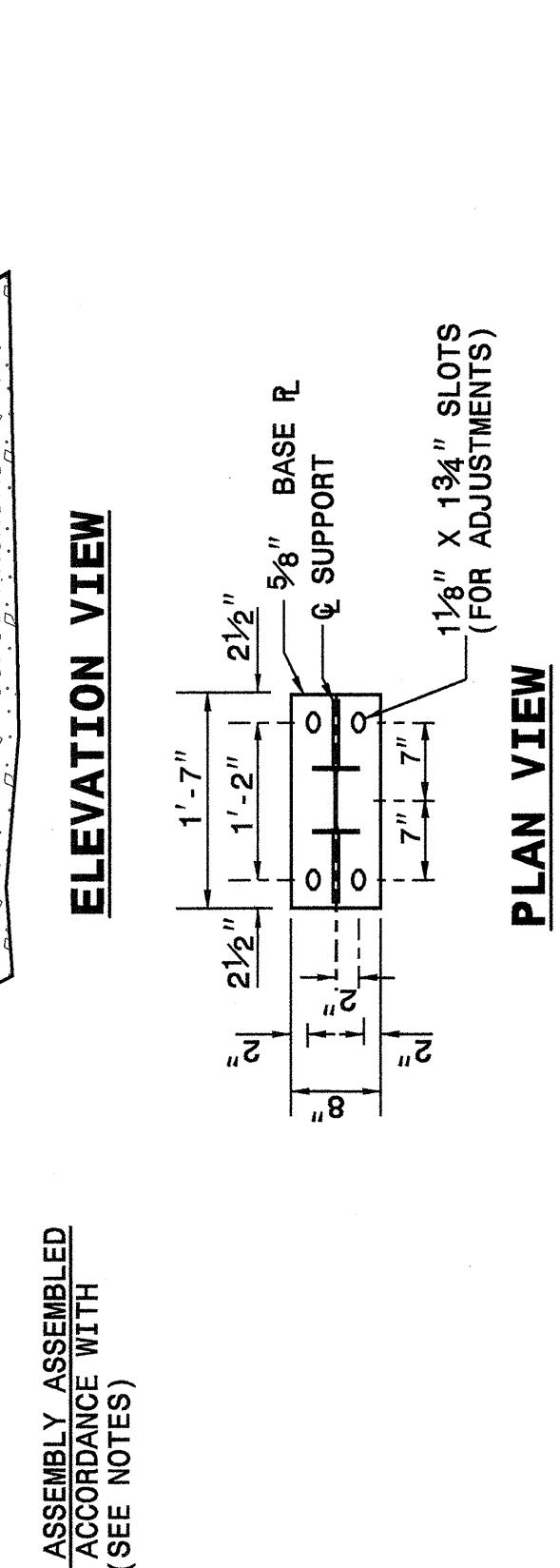
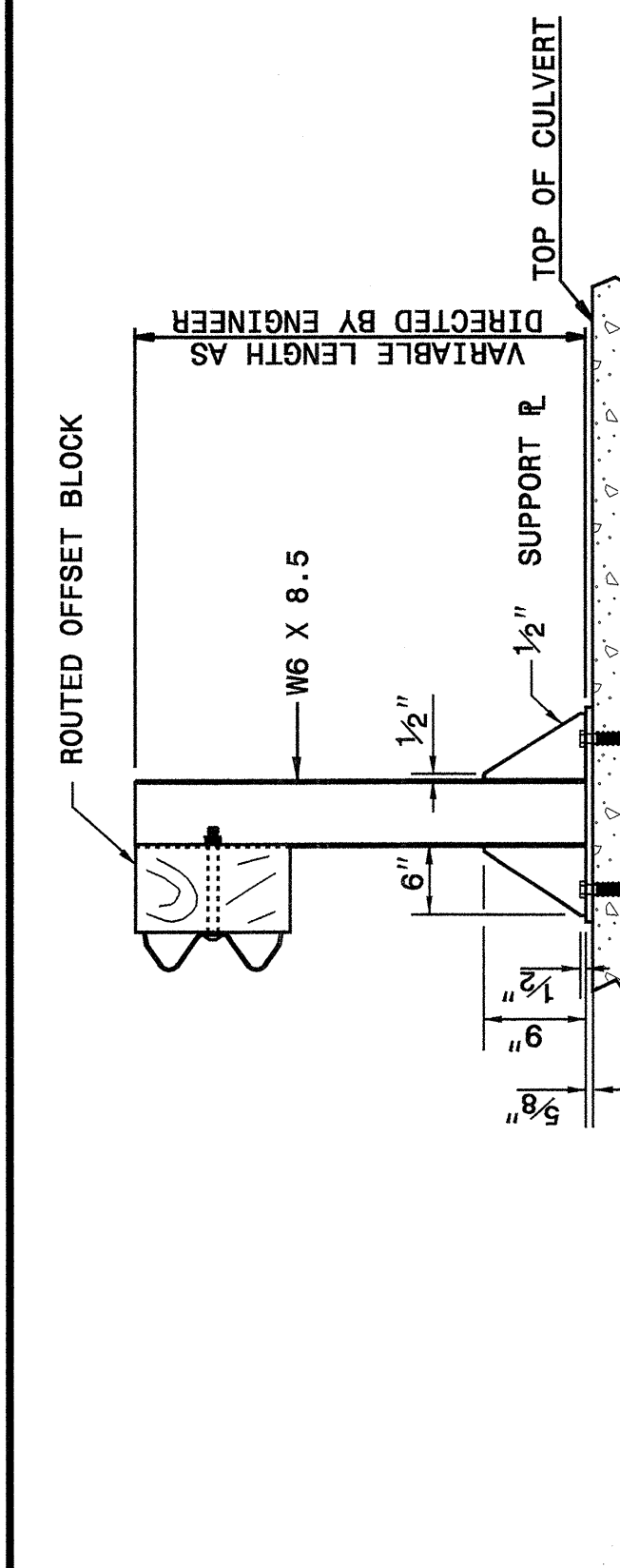
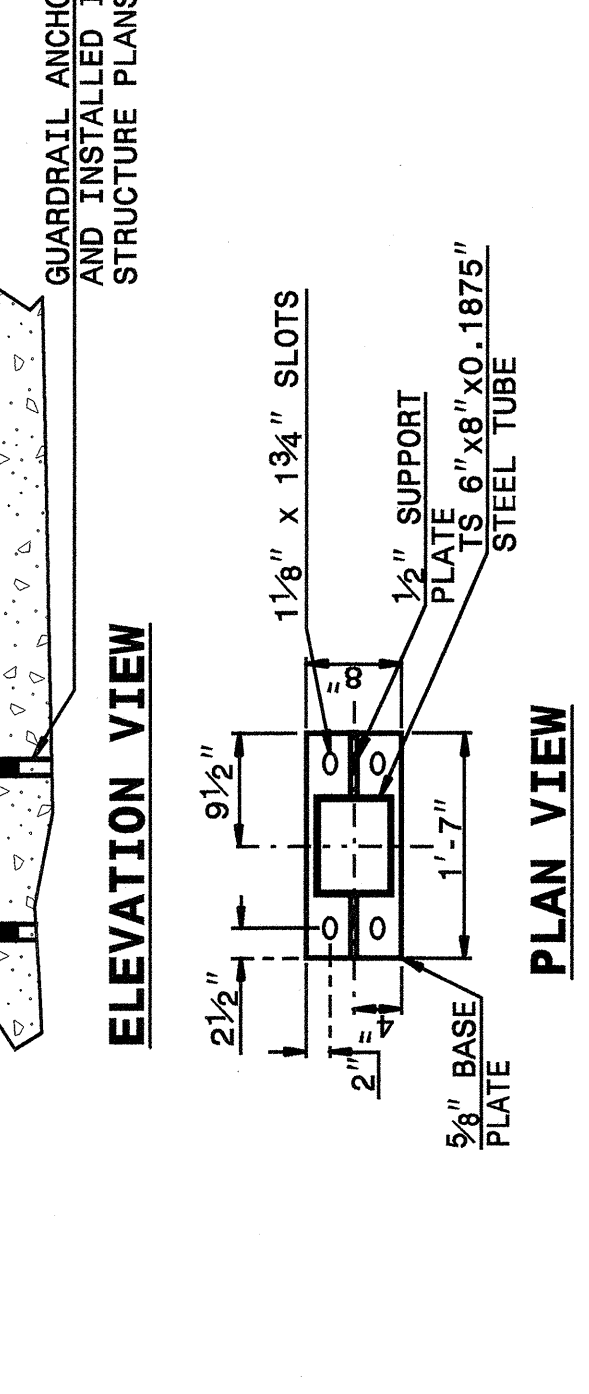
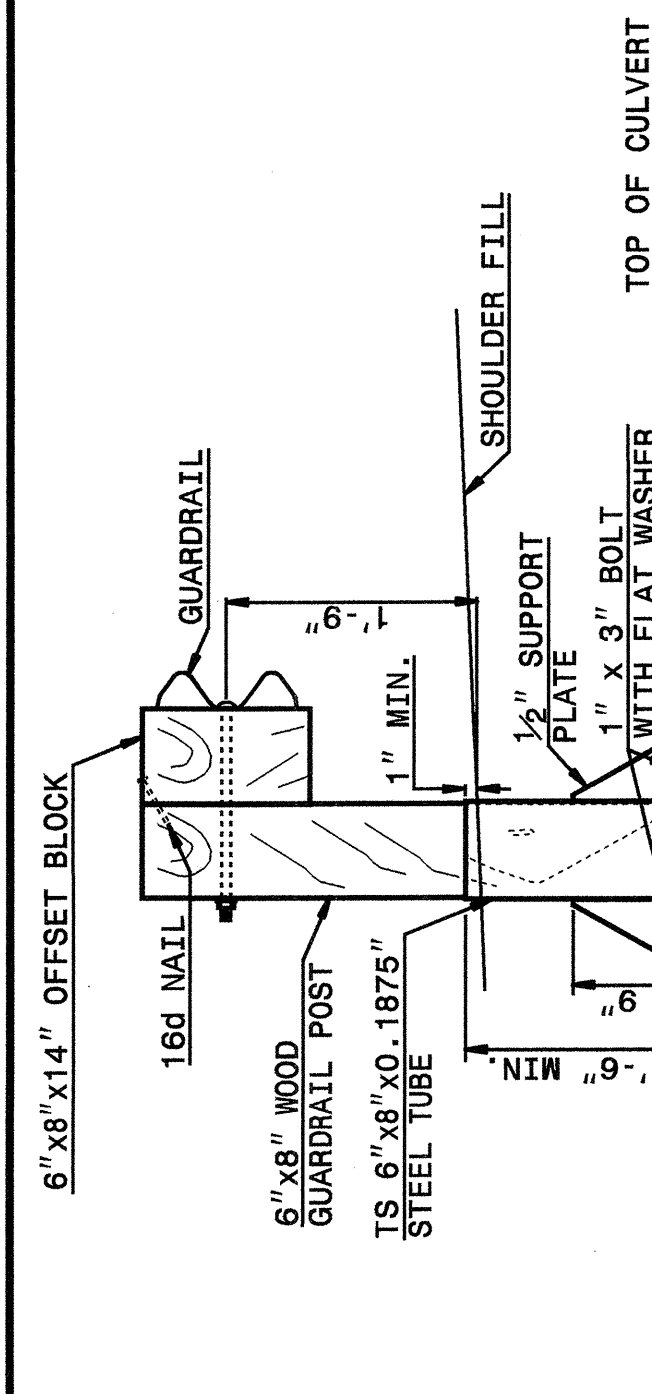

STATE OF
 NORTH CAROLINA
 DEPT. OF TRANSPORTATION
 RALEIGH, N.C.

ENGLISH DETAIL DRAWING FOR
STRUCTURE ANCHOR UNITS
 ANCHORAGE FOR GUARDRAIL POST ON BOX CULVERT

SHEET 1 OF 4
862D03

NOTES FOR: GUARDRAIL POST ANCHORED TO STRUCTURE:
 -USE FULL LENGTH 3/4" BUTT WELDS AT ALL LOCATIONS OF CONTACT BETWEEN THE BASE PLATE, SUPPORT PLATES AND STEEL POST OR STEEL TUBE.
 -USE POST AND POST BASE PLATES CONFORMING TO THE REQUIREMENTS OF A.S.T.M. A-36 AND GALVANIZED AFTER FABRICATION TO CONFORM TO A.S.T.M. A-123.
 -USE WOOD POSTS WHICH FIT SNUGLY IN THE STEEL TUBE WITH A MAXIMUM OF 1/8" CLEARANCE BETWEEN TUBE WALL AND POST.

NEW STRUCTURES:
 -ATTACH POST TO INSERT ASSEMBLY UNITS (USING ANCHOR BOLTS SUPPLIED WITH INSERTS) WHICH HAVE BEEN CAST INTO THE STRUCTURE DURING CONSTRUCTION.

EXISTING STRUCTURES:
 -USE CONCRETE ANCHORS CONSISTING OF A STUD BOLT WITH NUT AND WASHER. USE STUDS THREADED ON ONE END AND HAVING AN EXPANDED WEDGE ASSEMBLY POSITIONED AROUND A TAPERED AREA AT THE OTHER END. USE ANCHORS WHICH PROVIDE A MINIMUM SAFE HOLDING POWER OF 2875 LBS. FOR A 3/4" OR 1" DIAMETER BOLT. CALCULATE HOLDING POWER BASED ON 1/4 THE ACTUAL HOLDING POWER OF THE ANCHOR IN 3500 PSI CONCRETE AS DETERMINED BY AN APPROVED COMMERCIAL TESTING LABORATORY.

-USE ANCHORS GALVANIZED IN ACCORDANCE WITH A.S.T.M. A-153. SIZE HOLES FOR THE CONCRETE ANCHORS IN ACCORDANCE WITH THE ANCHOR MANUFACTURER'S RECOMMENDATIONS. DRILL HOLES WITH A CARBIDE OR DIAMOND TIPPED MASONRY BIT POWERED BY A ROTARY OR ROTARY IMPACT DRILL. NO OTHER IMPACT TOOLS WILL BE PERMITTED. DRILL HOLES VERTICALLY. FURNISH DOCUMENTATION OF HOLE SIZE RECOMMENDED FOR THE SPECIFIED ANCHOR TO THE ENGINEER BEFORE DRILLING HOLES. THOROUGHLY CLEAN HOLES FOR ANCHORS OF ALL CONCRETE CHIPS, DUST, GREASE, OIL, ETC. BEFORE ANCHORS ARE INSTALLED. REPAIR ALL DAMAGE CAUSED BY THIS WORK TO THE SATISFACTION OF THE ENGINEER.

ANCHORAGE FOR GUARDRAIL POST ON BOX CULVERT

STATE OF
 NORTH CAROLINA
 DEPT. OF TRANSPORTATION
 DIVISION OF HIGHWAYS
 RALEIGH, N.C.

ENGLISH DETAIL DRAWING FOR
STRUCTURE ANCHOR UNITS
 GUARDRAIL ANCHOR UNIT, TYPE III
 FOR ATTACHMENT TO RAIL ON BRIDGE

SHEET 2 OF 4
862D03

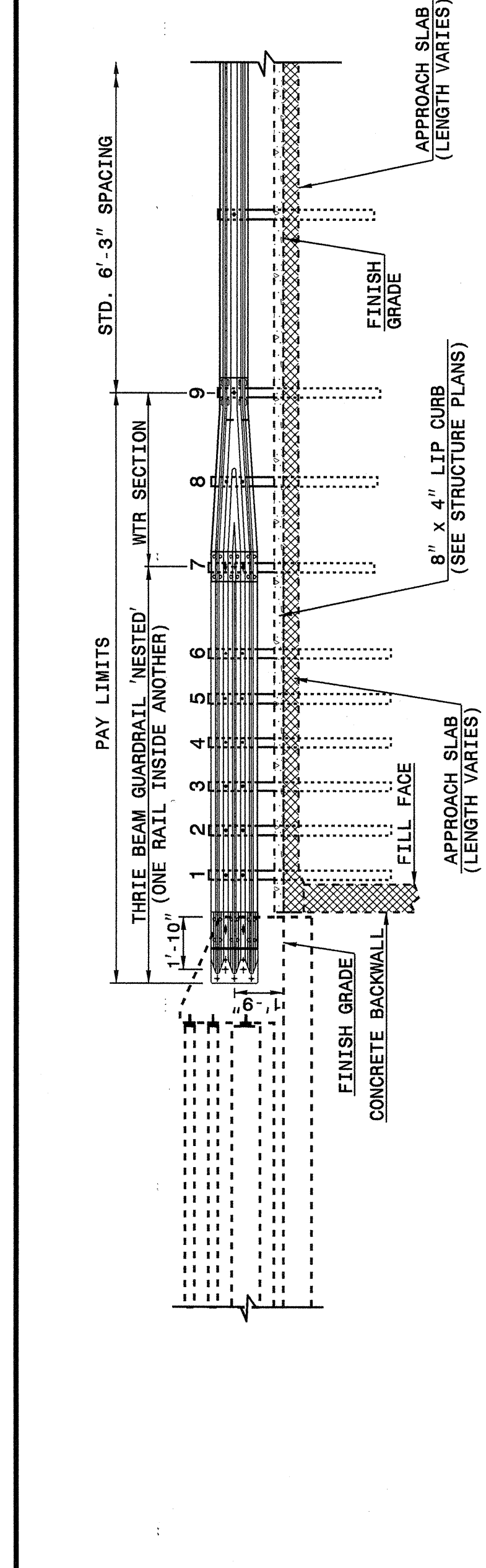

NOTE:
 **POST NOT REQUIRED FOR SKEW ANGLES GREATER THAN 150° OR LESS THAN 30° UNLESS OTHERWISE DIRECTED BY THE ENGINEER.
 *THE DISTANCE FROM END OF BRIDGE RAIL TO CENTER LINE OF THE FIRST POST SHOULD BE 11 1/2" IF CONCRETE BACKWALL IS NOT PRESENT.
 -SHOULDER BERM GUTTER MUST BE INSTALLED WITHIN THE PAY LIMITS IF THE ANCHOR UNIT IS NOT ADJACENT TO AN APPROACH SLAB.
 -USE NO STEEL POSTS WITHIN THE GUARDRAIL ANCHOR UNIT LIMITS.
 -LAP JOINTS IN THE DIRECTION OF TRAFFIC FLOW.
 -SEE SHEET 4 FOR POST SECTIONS 1 THRU 9.

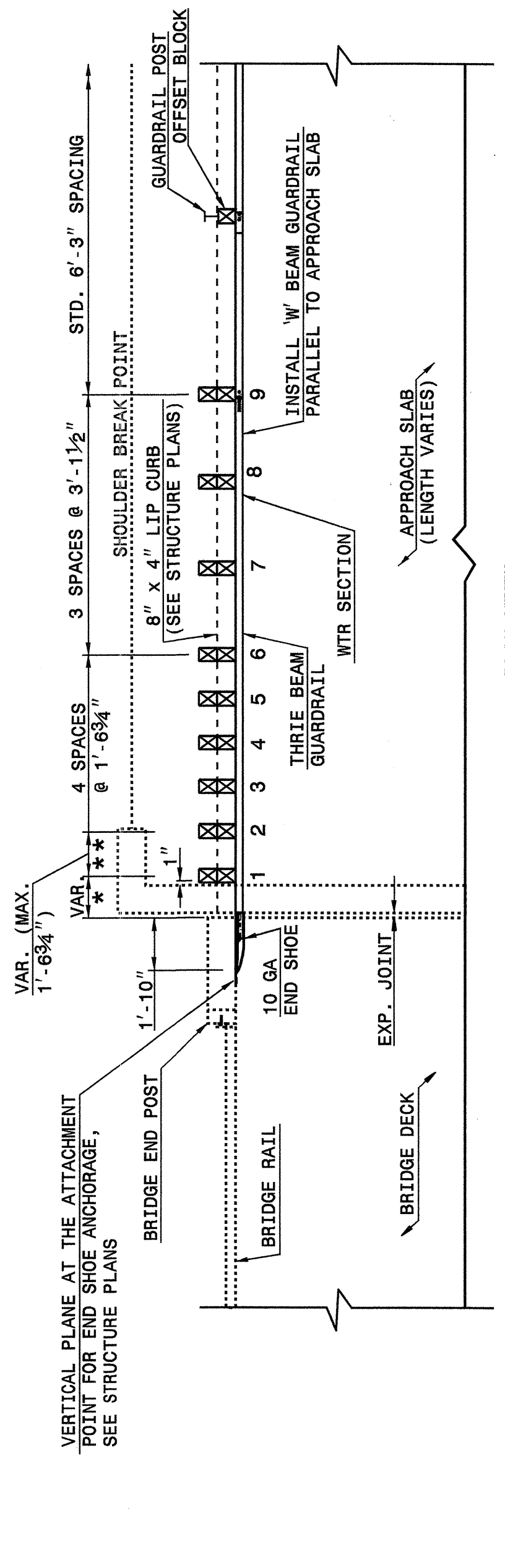

STATE OF
 NORTH CAROLINA
 DEPT. OF TRANSPORTATION
 RALEIGH, N.C.

ENGLISH DETAIL DRAWING FOR
STRUCTURE ANCHOR UNITS
 GUARDRAIL ANCHOR UNIT, TYPE III
 FOR ATTACHMENT TO RAIL ON BRIDGE

SHEET 2 OF 4
862D03

**GUARDRAIL ANCHOR UNIT, TYPE III
 FOR ATTACHMENT TO RAIL ON BRIDGE**

PROJECT SERVICES UNIT
 STANDARDS AND SPECIAL DESIGN
 Office 919-250-4128 FAX 919-250-4119

SEE PLATE FOR TITLE

ORIGINAL BY: 2002 STANDARDS DATE: 01-15-02
 MODIFIED BY: E.E. WARD DATE: 04-07-04
 CHECKED BY: *Joel S. Howerton* DATE: 10/21/04
 FILE SPEC.: stds\02stdstodetails/english\862d03.dgn

