

HALF SECTION @ INTERMEDIATE DIAPHRAGMS

HALF SECTION @ 1'-0" Ø VOIDS

TYPICAL SECTION

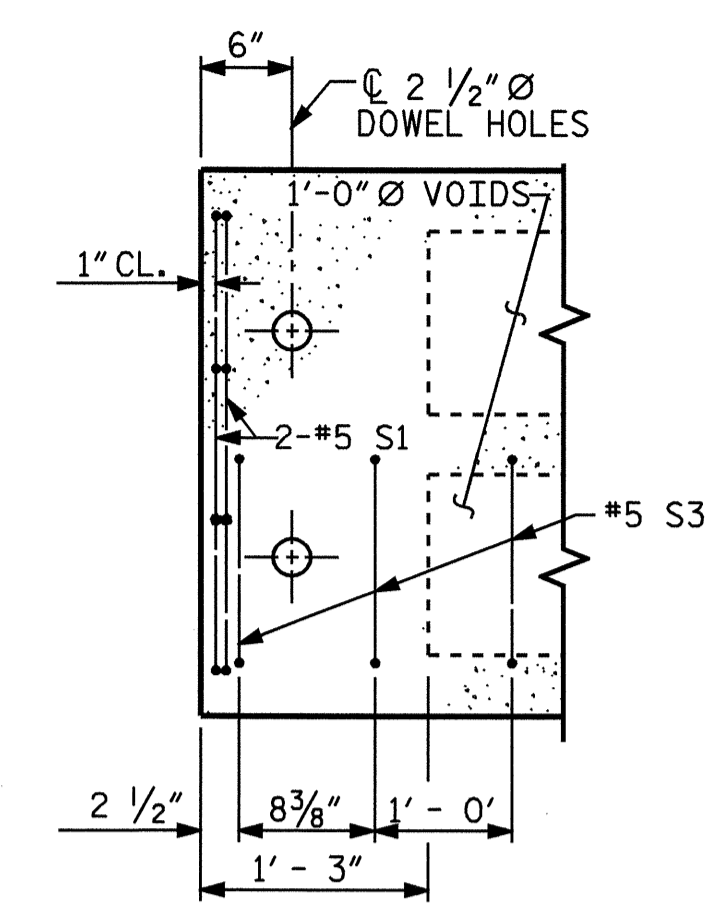

PART PLAN-EXTERIOR SECTION

NOTE: EXTERIOR SECTION SHOWN-INTERIOR SECTION SIMILAR EXCEPT OMIT S3 BARS.

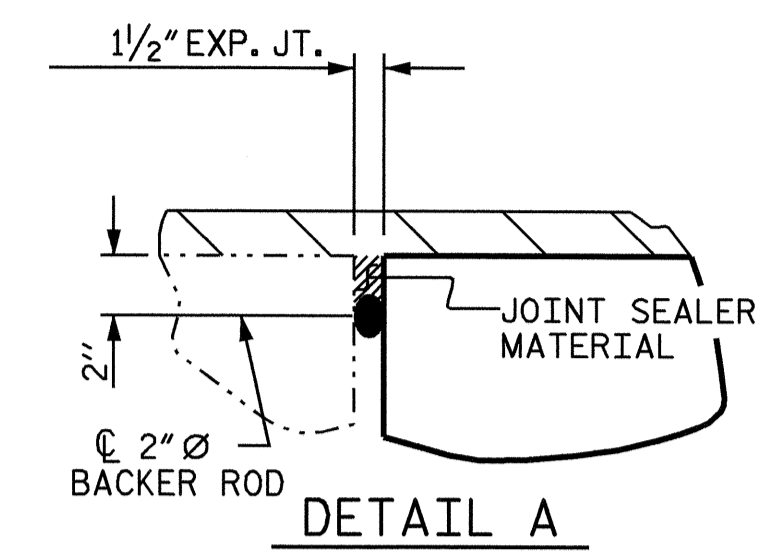

DETAIL A

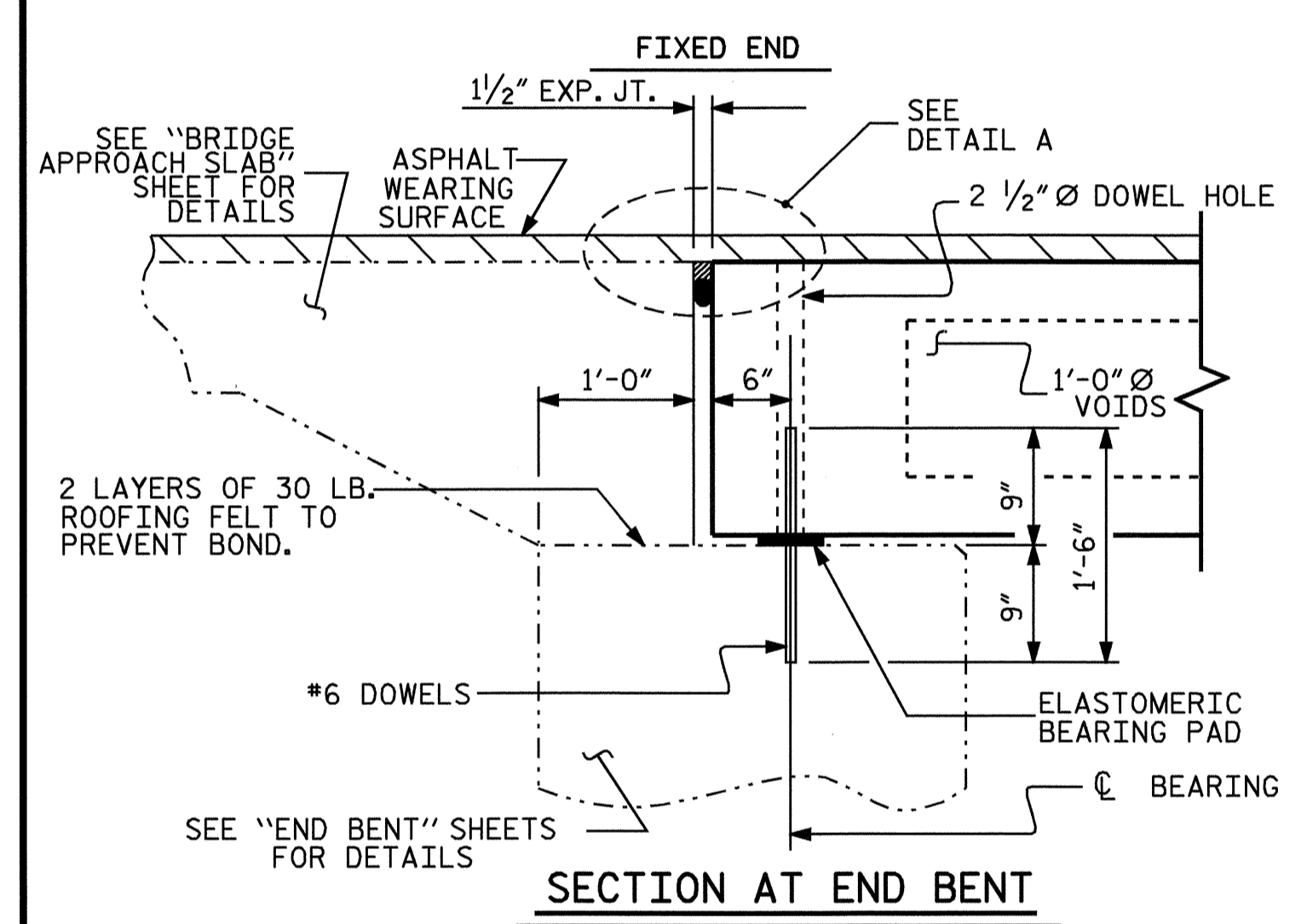

SECTION AT END BENT

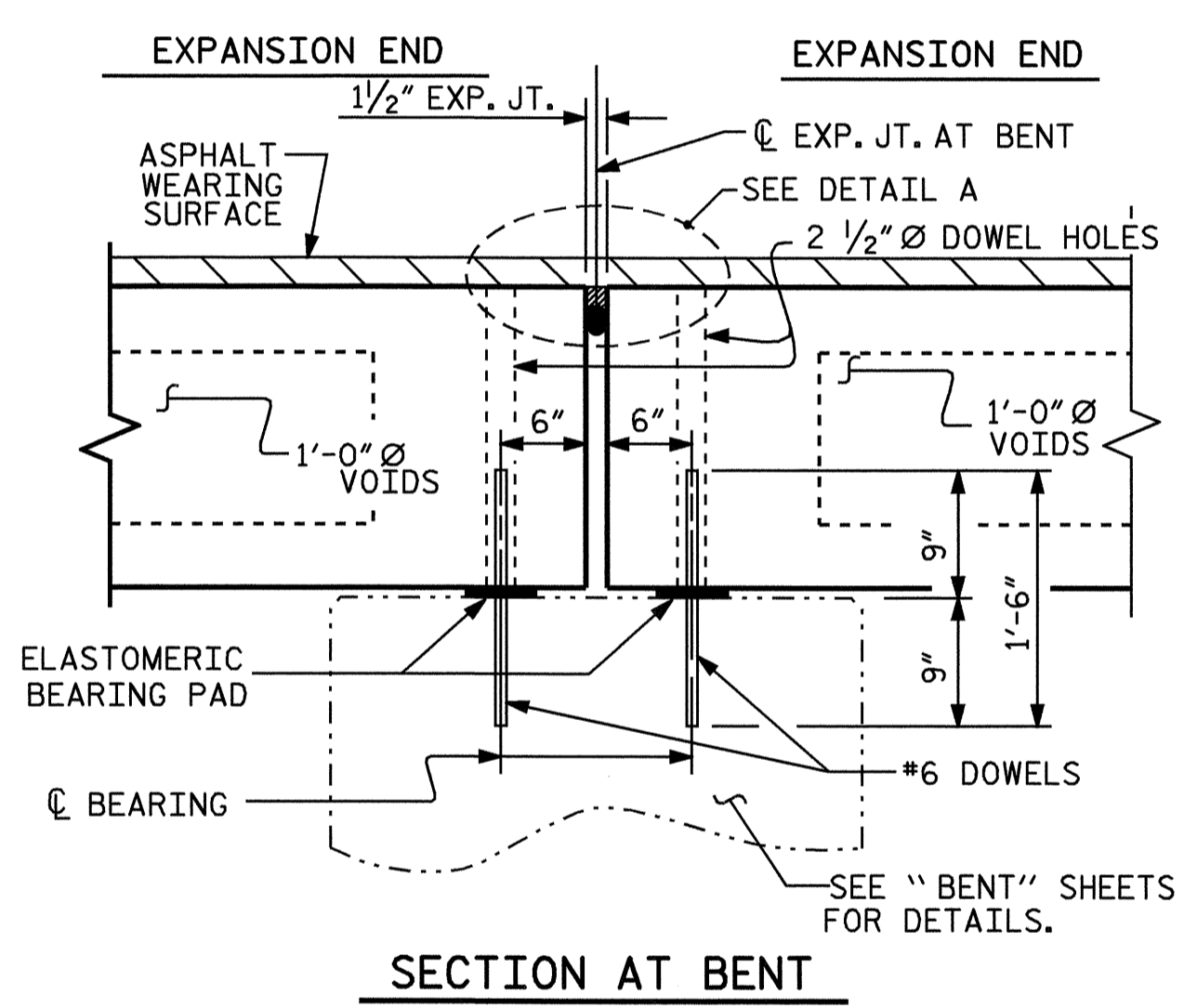

SECTION AT BENT

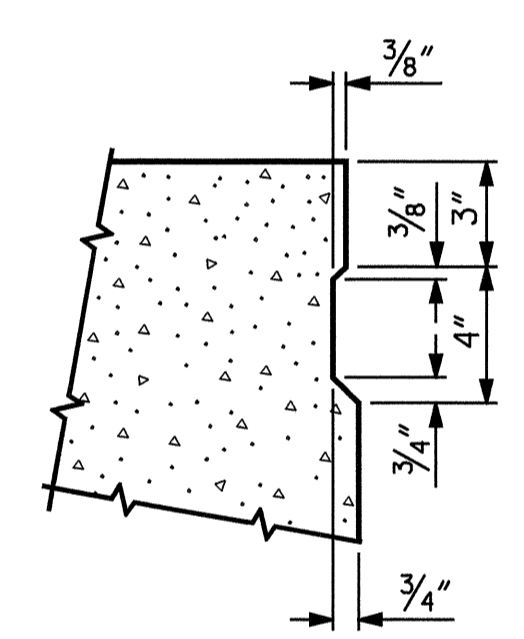

SHEAR KEY DETAIL
 NOTE: OMIT SHEAR KEY ON OUTSIDE FACE OF EXTERIOR CORED SLABS.

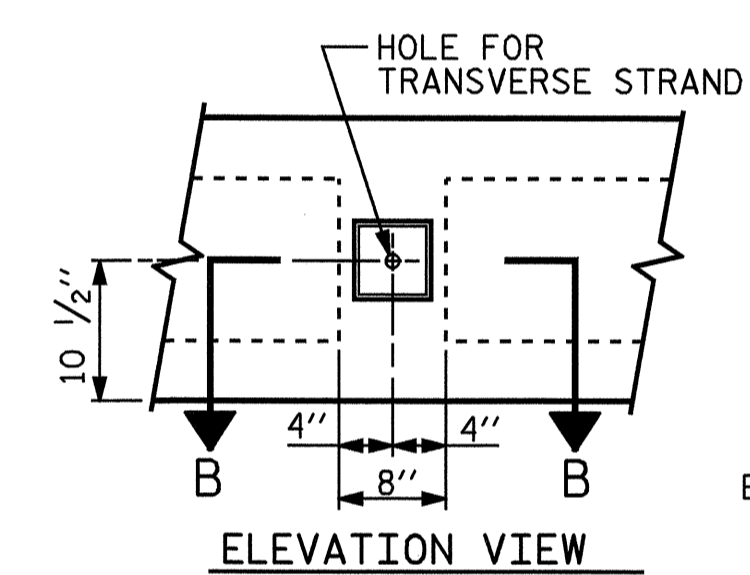

ELEVATION VIEW

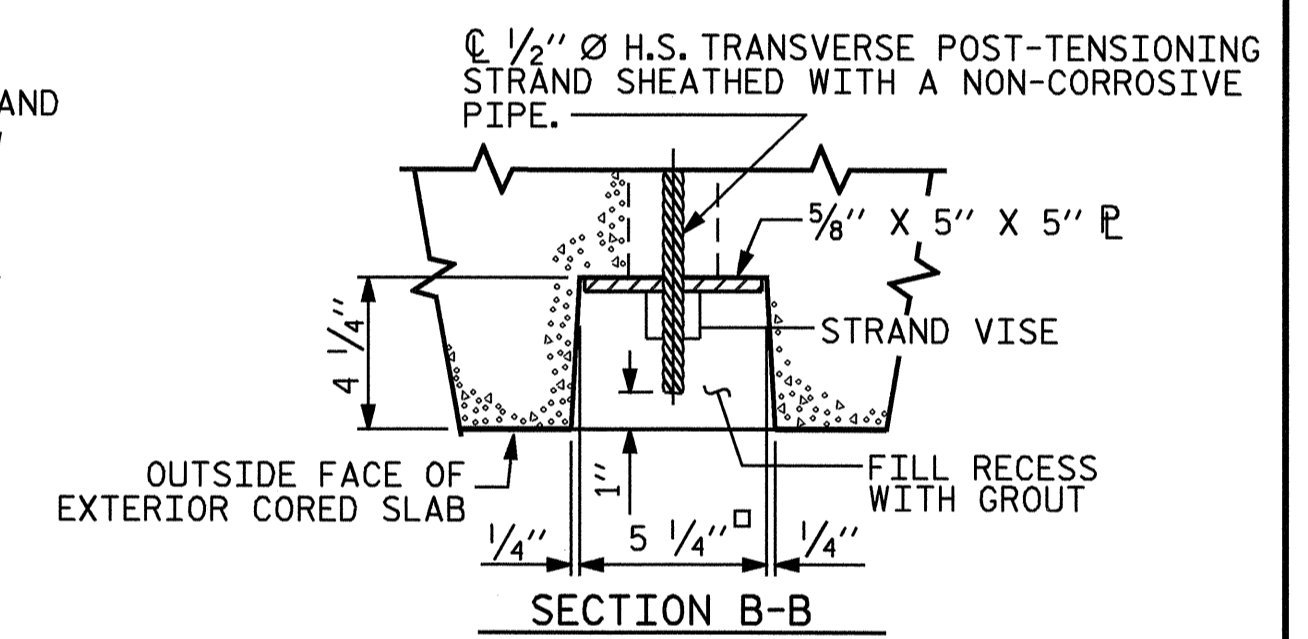

SECTION B-B

GRouted RECESS AT END OF POST-TENSIONED STRAND-CORED SLABS

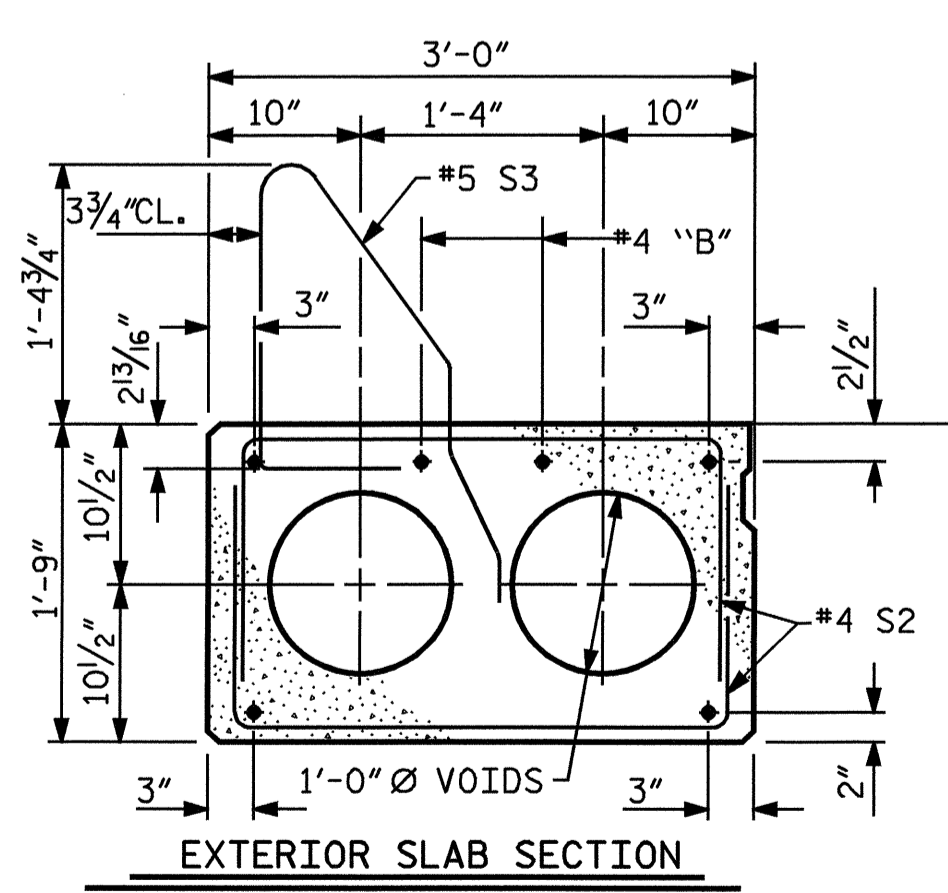

EXTERIOR SLAB SECTION
 (FOR PRESTRESSED STRAND LAYOUT, SEE INTERIOR SLAB SECTION.)

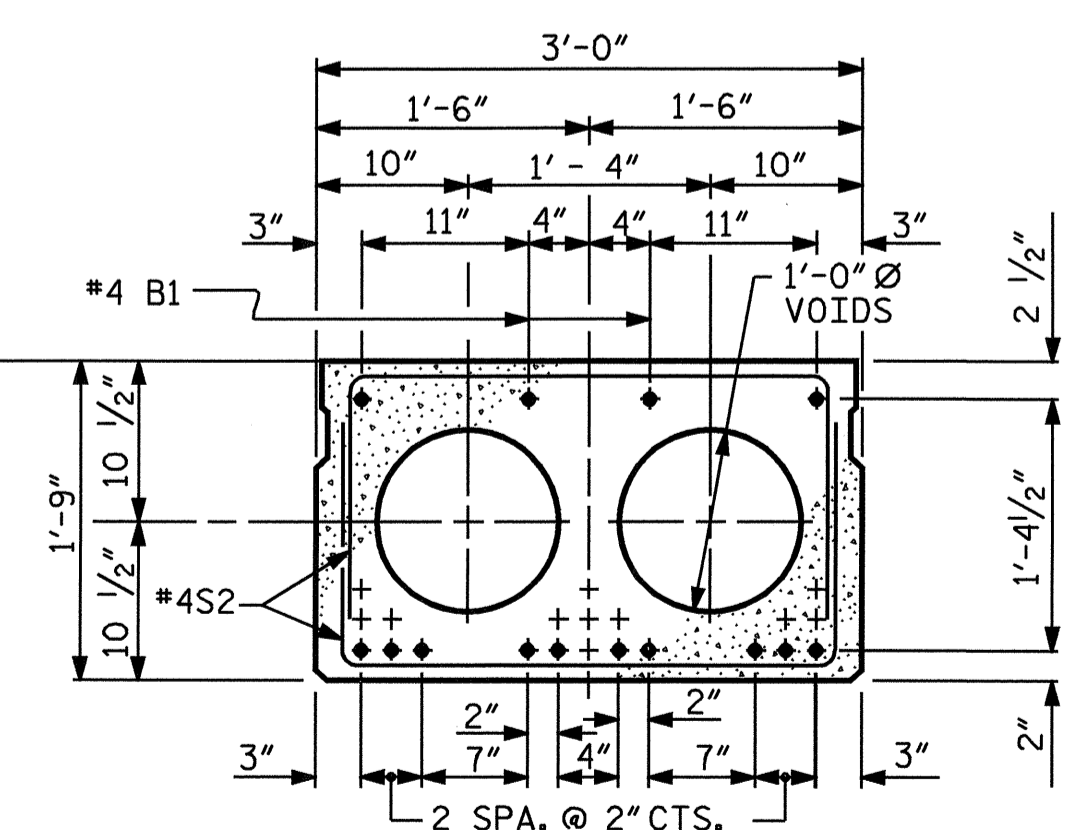

1/2" Ø LOW RELAXATION STRAND LAYOUT
 (12 STRANDS)
 SPAN A

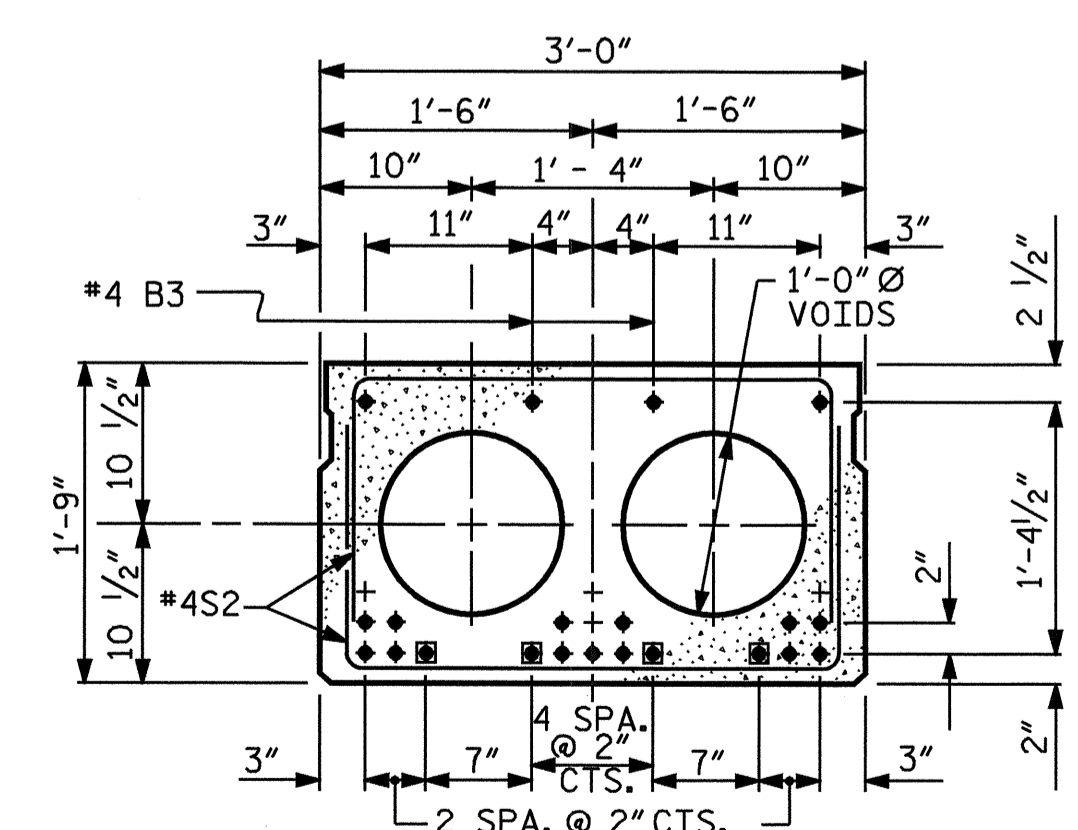

1/2" Ø LOW RELAXATION STRAND LAYOUT
 (19 STRANDS, 4 SHEATHED)
 SPAN B

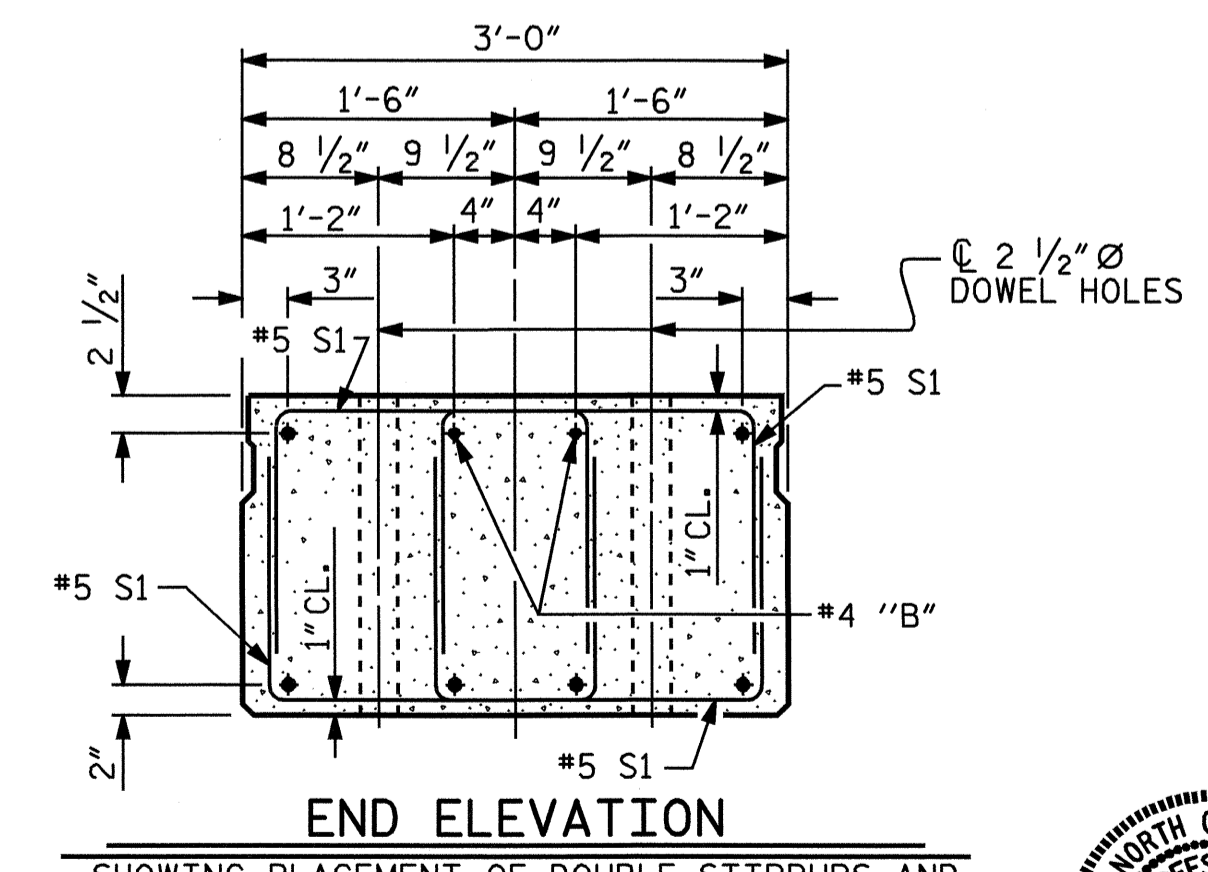

END ELEVATION
 SHOWING PLACEMENT OF DOUBLE STIRRUPS AND LOCATION OF DOWEL HOLES. (STRAND LAYOUT NOT SHOWN.)
 INTERIOR SLAB SECTION SHOWN-EXTERIOR SLAB SECTION SIMILAR EXCEPT SHEAR KEY LOCATION.

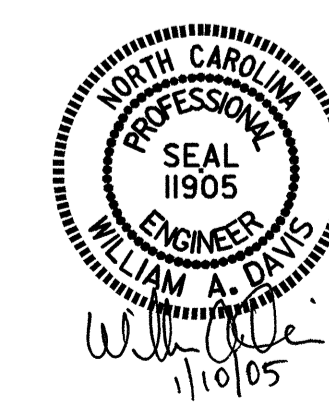

PROJECT NO. B-3182
HALIFAX COUNTY
 STATION: 15+07.50-L

SHEET 1 OF 4

| STATE OF NORTH CAROLINA DEPARTMENT OF TRANSPORTATION RALEIGH | | | | | SHEET NO. |
|---|-----|-------|-----|-----|--------------|
| STANDARD 3'-0" X 1'-9" PRESTRESSED CONCRETE CORED SLAB UNIT | | | | | S-4 |
| REVISIONS | | | | | TOTAL SHEETS |
| NO. | BY: | DATE: | NO. | BY: | DATE: |
| 1 | | | 3 | | |
| 2 | | | 4 | | |

DRAWN BY: J.D. HAWK DATE: 3/15/04
 CHECKED BY: J.G. KHARVA DATE: 9/04

BOND SHALL BE BROKEN ON THESE STRANDS FOR A DISTANCE OF 4'-0" FROM END OF CORED SLAB UNIT, SEE STANDARD SPECIFICATIONS ARTICLE 1078-7.

66P