

CURVED GIRDER ELEVATION

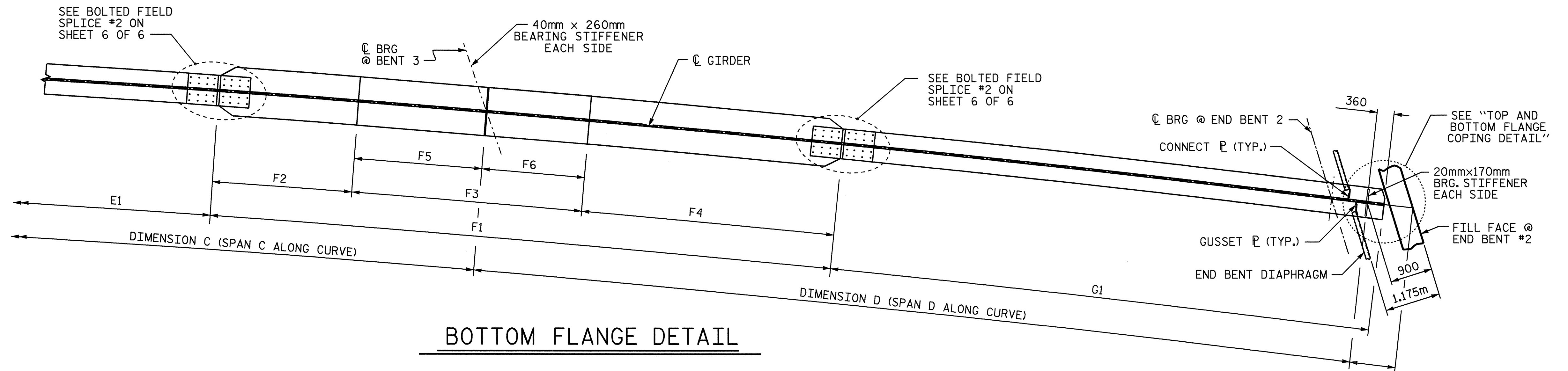

BOTTOM FLANGE DETAIL

SHEAR STUD SPACING TABLE FOR SPAN C AND D GIRDERS									
	S14	S15	S16	S17	S18	S19	S20	S21	S22
GIRDER 1	81 SPA. @ 350mm CTS.	525	416	28 SPA. @ 360mm CTS.	53 SPA. @ 300mm CTS.	416	448	24 SPA. @ 300mm CTS.	62 SPA. @ 225mm CTS.
GIRDER 2	82 SPA. @ 345mm CTS.	498	512	29 SPA. @ 360mm CTS.	54 SPA. @ 280mm CTS.	513	522	81 SPA. @ 235mm CTS.	NOT REQD.
GIRDER 3	83 SPA. @ 340mm CTS.	476	522	28 SPA. @ 360mm CTS.	55 SPA. @ 275mm CTS.	522	435	81 SPA. @ 240mm CTS.	NOT REQD.
GIRDER 4	80 SPA. @ 350mm CTS.	530	453	30 SPA. @ 350mm CTS.	56 SPA. @ 260mm CTS.	453	505	77 SPA. @ 255mm CTS.	NOT REQD.

NOTE : ALL DIMENSIONS ARE SHOWN IN MILLIMETERS AND ARE MEASURED ALONG THE \bar{C} OF GIRDER.

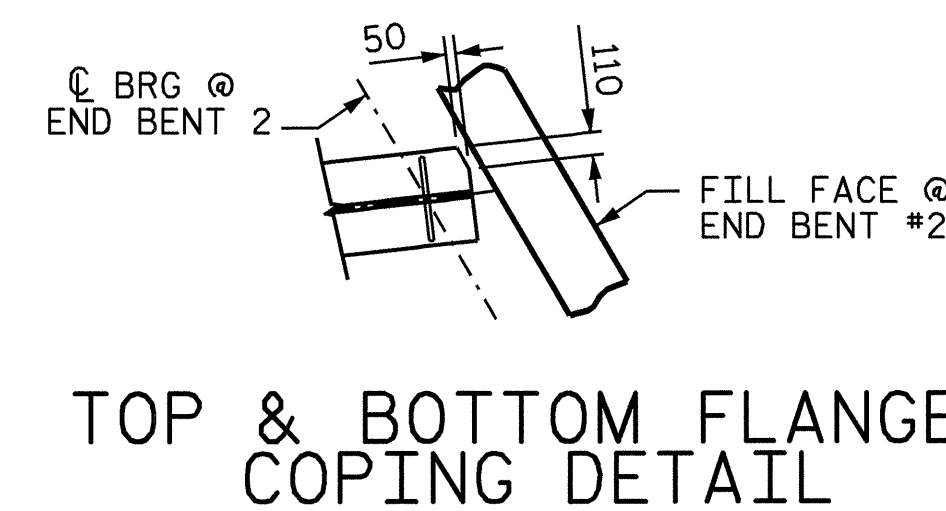

	DIM. C	DIM. D	DIM. F1	DIM. F2	DIM. F3	DIM. F4	DIM. F5	DIM. F6	DIM. G1
GIRDER 1	57.324m	35.500m	26.812m	5.880m	10.252m	10.680m	4.880m	5.372m	19.808m
GIRDER 2	57.102m	35.358m	26.585m	5.858m	10.034m	10.693m	5.026m	5.008m	20.017m
GIRDER 3	56.880m	35.216m	26.249m	5.834m	9.817m	10.598m	5.174m	4.643m	20.335m
GIRDER 4	56.658m	35.074m	25.966m	5.811m	9.599m	10.556m	5.321m	4.278m	20.600m

NOTE : ALL DIMENSIONS ARE MEASURED ALONG THE \bar{C} OF GIRDER.

ROWS OF STUDS	
GIRDER 1	596 ROWS OF STUDS @ 3 STUDS PER ROW
GIRDER 2	597 ROWS OF STUDS @ 3 STUDS PER ROW
GIRDER 3	592 ROWS OF STUDS @ 3 STUDS PER ROW
GIRDER 4	588 ROWS OF STUDS @ 3 STUDS PER ROW

DRAWN BY : B.N.BARODAWALA DATE : 10-18-04
 CHECKED BY : MIKE ALLEN DATE : 12-04

21-DEC-2004 15:18
 W:\SquadL\0977a\str5\barodawala\R0977A.sd.SS.05.dgn
 lsutton

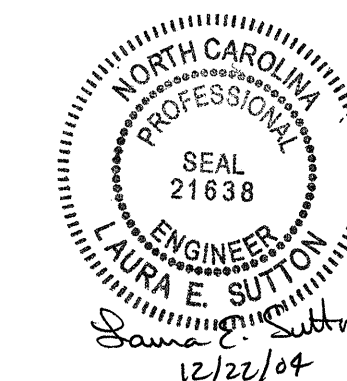

PROJECT NO. R-0977A
 CHEROKEE COUNTY
 STATION: 68+58.000-LREV-

SHEET 3 OF 6

STATE OF NORTH CAROLINA
 DEPARTMENT OF TRANSPORTATION
 RALEIGH

SUPERSTRUCTURE
 STRUCTURAL
 STEEL DETAILS

REVISIONS						SHEET NO.
NO.	BY:	DATE:	NO.	BY:	DATE:	S-190
1			3			TOTAL SHEETS
2			4			230

STR. #5