

**GIRDER ELEVATION**

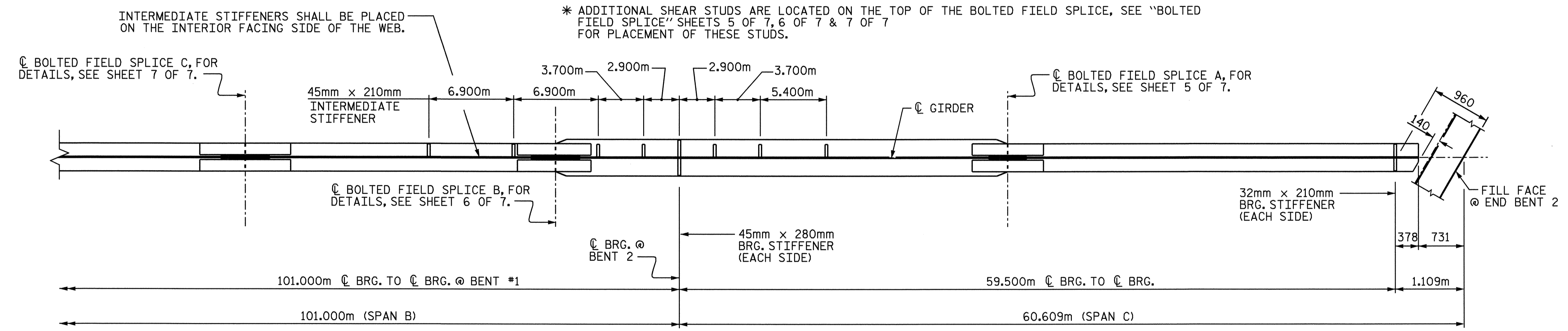

**BOTTOM FLANGE DETAIL**

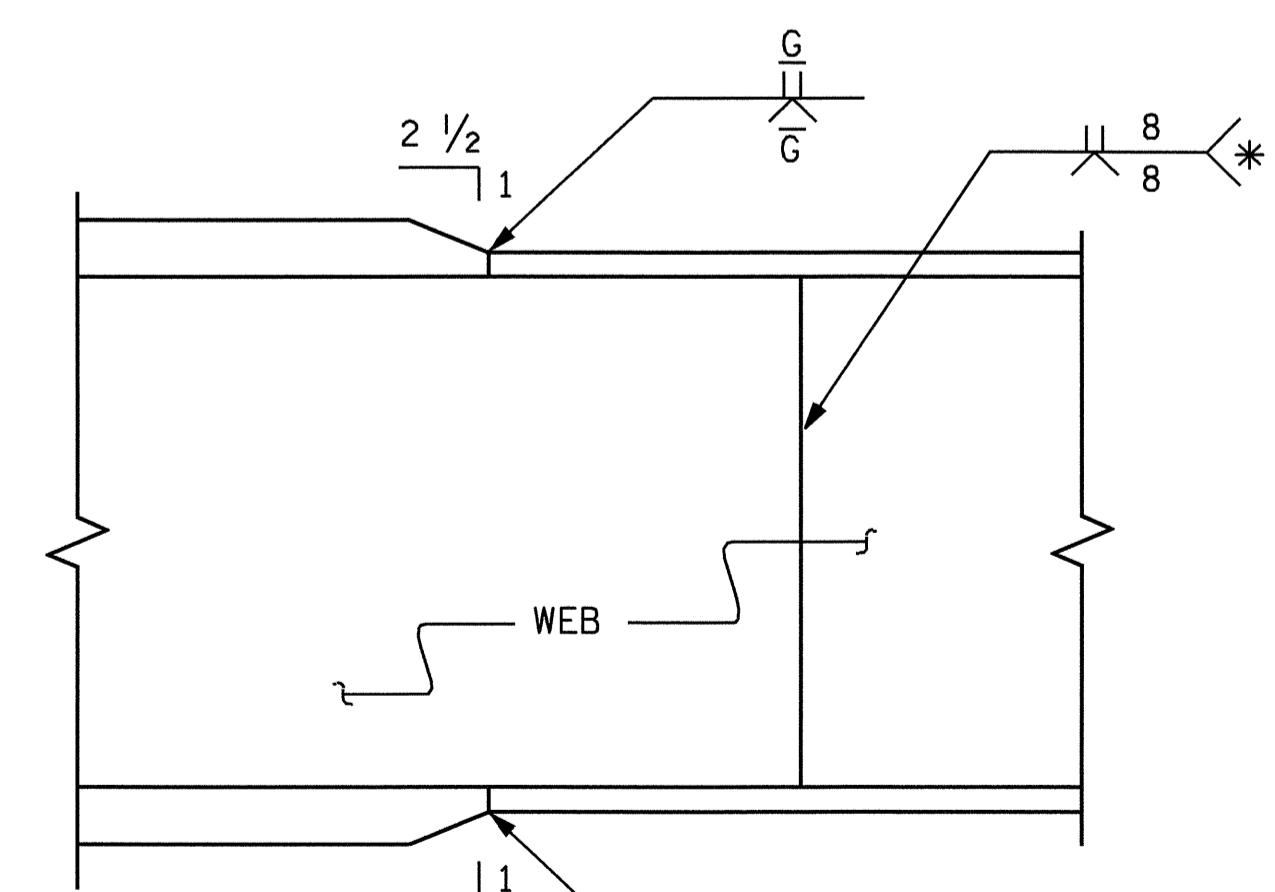

**TYPICAL FLANGE AND WEB BUTT JOINT**

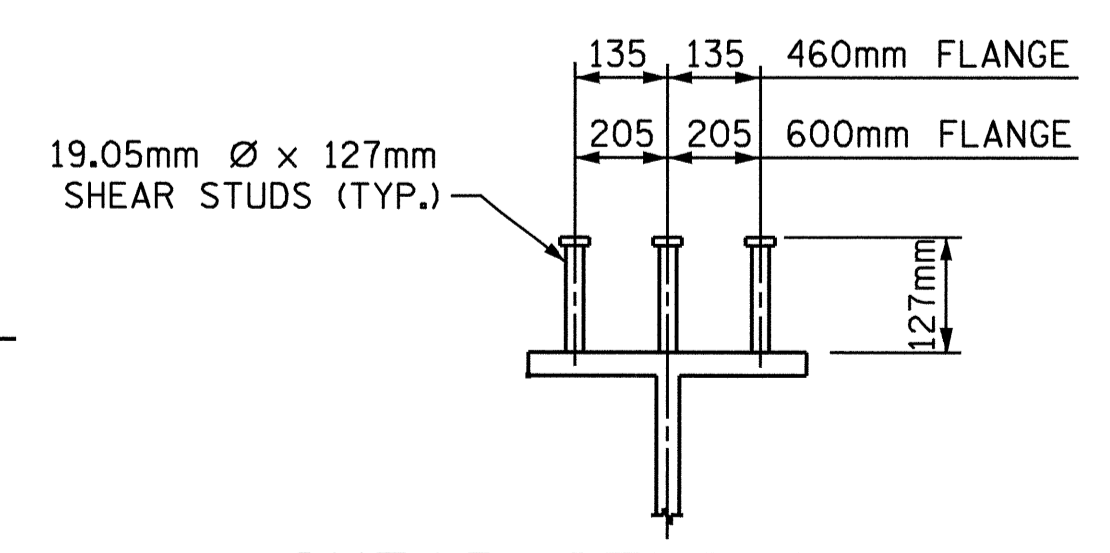
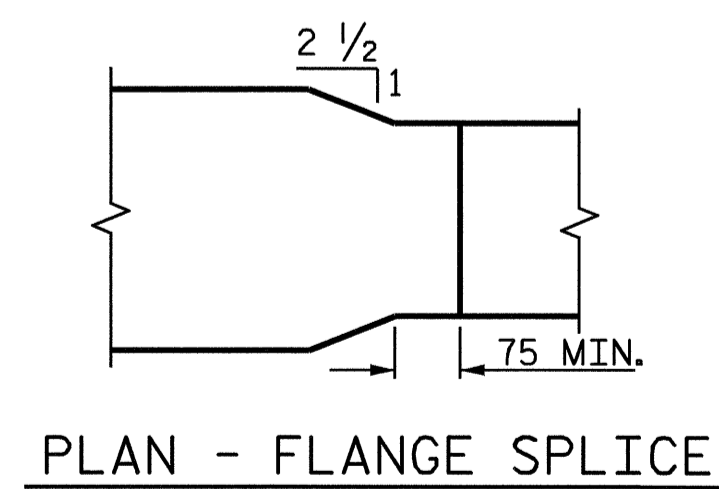

**SHEAR STUD DETAILS**

NOTE:  
 \*\* USE GRADE HPS 485W STEEL FOR FLANGES AS SHOWN IN GIRDER ELEVATION.  
 FOR ALL OTHER PARTS OF GIRDER, USE AASHTO M270 GRADE 345W.

PROJECT NO. R-0977A  
CHEROKEE COUNTY  
 STATION: 16+02.300-LC1B-

SHEET 2 OF 7  
 STATE OF NORTH CAROLINA  
 DEPARTMENT OF TRANSPORTATION  
 RALEIGH  
 SUPERSTRUCTURE  
 STRUCTURAL STEEL  
 DETAILS

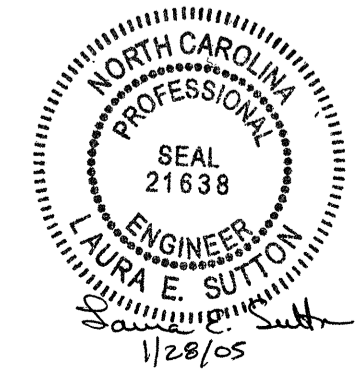

DRAWN BY : A.S. CALLAWAY DATE : 3/8/04  
 CHECKED BY : B.N. BARODAWALA DATE : 6/17/04

REVISIONS						SHEET NO.
NO.	BY:	DATE:	NO.	BY:	DATE:	S-14
1			3			TOTAL SHEETS
2			4			230