

NOTES

PROVIDE 32mm HIGH BEAM BOLSTERS UPPER AT 1.2m CTS. ATOP THE METAL STAY-IN-PLACE FORMS TO SUPPORT THE BOTTOM MAT OF 'A' BARS. WHEN USING REMOVABLE FORMS, PROVIDE CONTINUOUS HIGH CHAIRS FOR METAL DECK (C.H.C.M.) @ 1.2m CTS. WITH A HEIGHT TO SUPPORT THE BOTTOM MAT OF 'A' BARS A CLEAR DISTANCE OF 65mm ABOVE THE TOP OF THE REMOVABLE FORM.

METAL STAY-IN-PLACE FORMS SHALL NOT BE WELDED TO BEAM OR GIRDER FLANGES IN THE ZONES REQUIRING CHIPPY V-NOTCH TEST. SEE STRUCTURAL STEEL DETAIL SHEETS.

PREVIOUSLY CAST CONCRETE IN A CONTINUOUS UNIT SHALL HAVE ATTAINED A MINIMUM COMPRESSIVE STRENGTH OF 20.7 MPa BEFORE ADDITIONAL CONCRETE IS CAST IN THE UNIT.

BARRIER RAIL AND PARAPET IN A CONTINUOUS UNIT SHALL NOT BE CAST UNTIL ALL SLAB CONCRETE IN THE UNIT HAS BEEN CAST AND HAS REACHED A MINIMUM COMPRESSIVE STRENGTH OF 20.7 MPa.

STRUCTURAL STEEL ERECTION IN A CONTINUOUS UNIT SHALL BE COMPLETE BEFORE FALSEWORK OR FORMS ARE PLACED ON THE UNIT.

THE CONTRACTOR MAY, WHEN NECESSARY, PROPOSE A SCHEME FOR AVOIDING INTERFERENCE BETWEEN METAL STAY-IN-PLACE FORM SUPPORTS OR FORMS AND GIRDER STIFFENERS OR CONNECTOR PLATES. THE PROPOSAL SHALL BE INDICATED, AS APPROPRIATE, ON EITHER THE STEEL WORKING DRAWINGS OR THE METAL STAY-IN-PLACE FORM WORKING DRAWINGS.

USE SAND LIGHTWEIGHT CONCRETE IN THE DECK SLAB. SEE SPECIAL PROVISIONS FOR REINFORCED CONCRETE DECK SLAB (SAND LIGHTWEIGHT CONCRETE).

CONCRETE SHALL BE EXCLUDED FROM THE METAL STAY-IN-PLACE FORM VALLEYS. SEE SPECIAL PROVISIONS FOR FABRICATED METAL STAY-IN-PLACE FORMS.

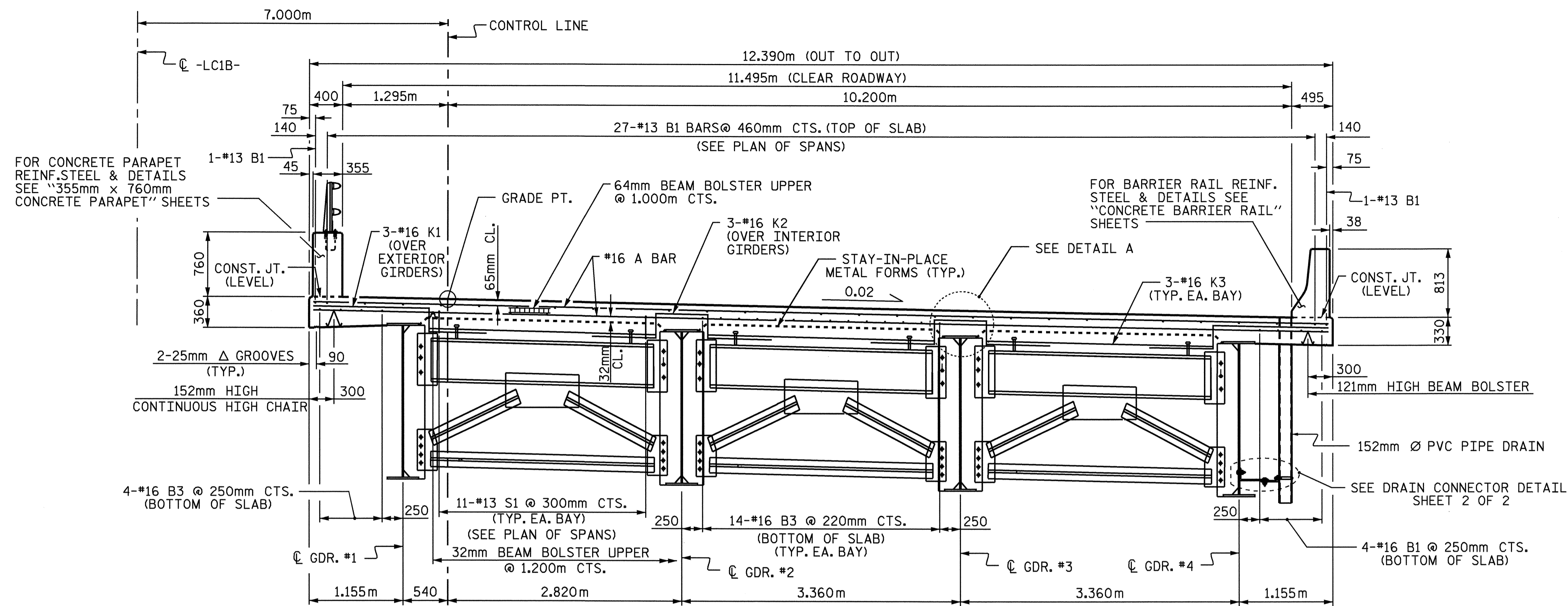

TYPICAL SECTION

(SHOWING END BENT DIAPHRAGMS)

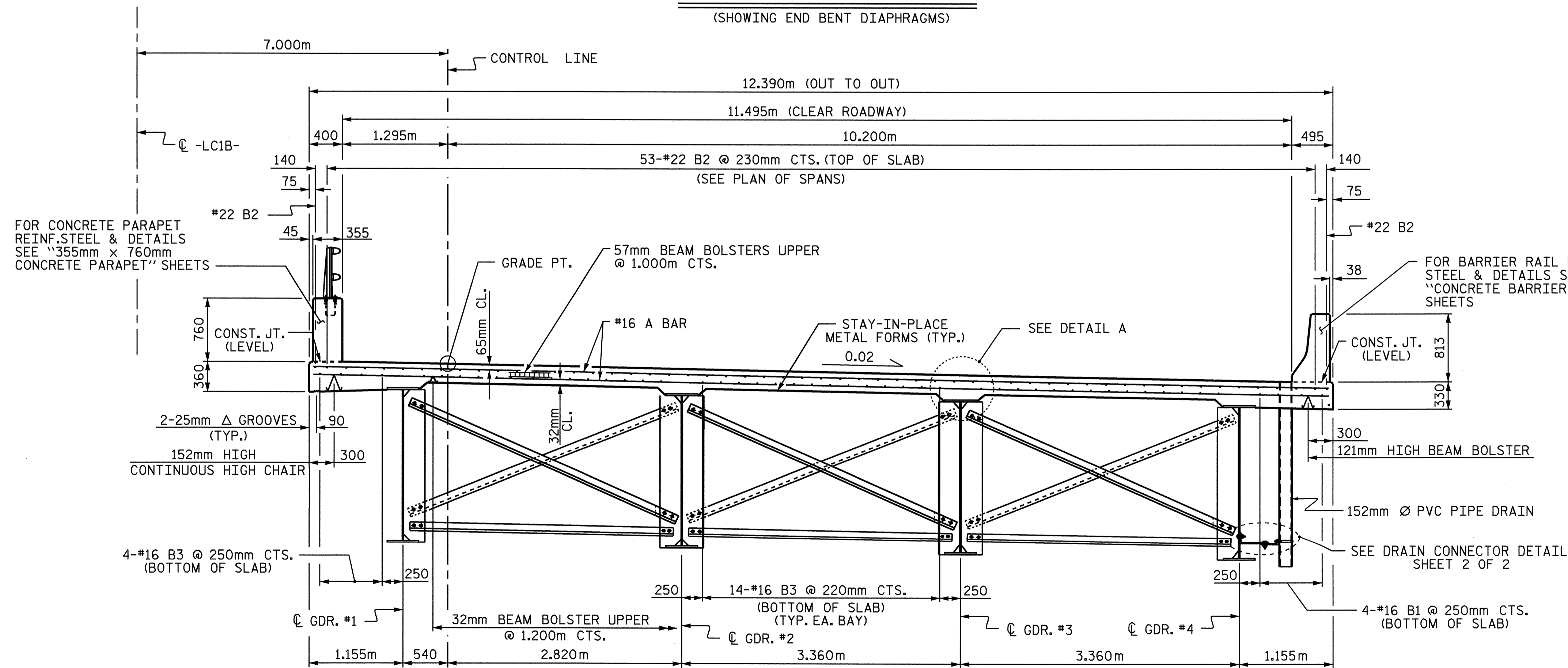

TYPICAL SECTION

(SHOWING BENT DIAPHRAGMS AND INTERMEDIATE DIAPHRAGMS)

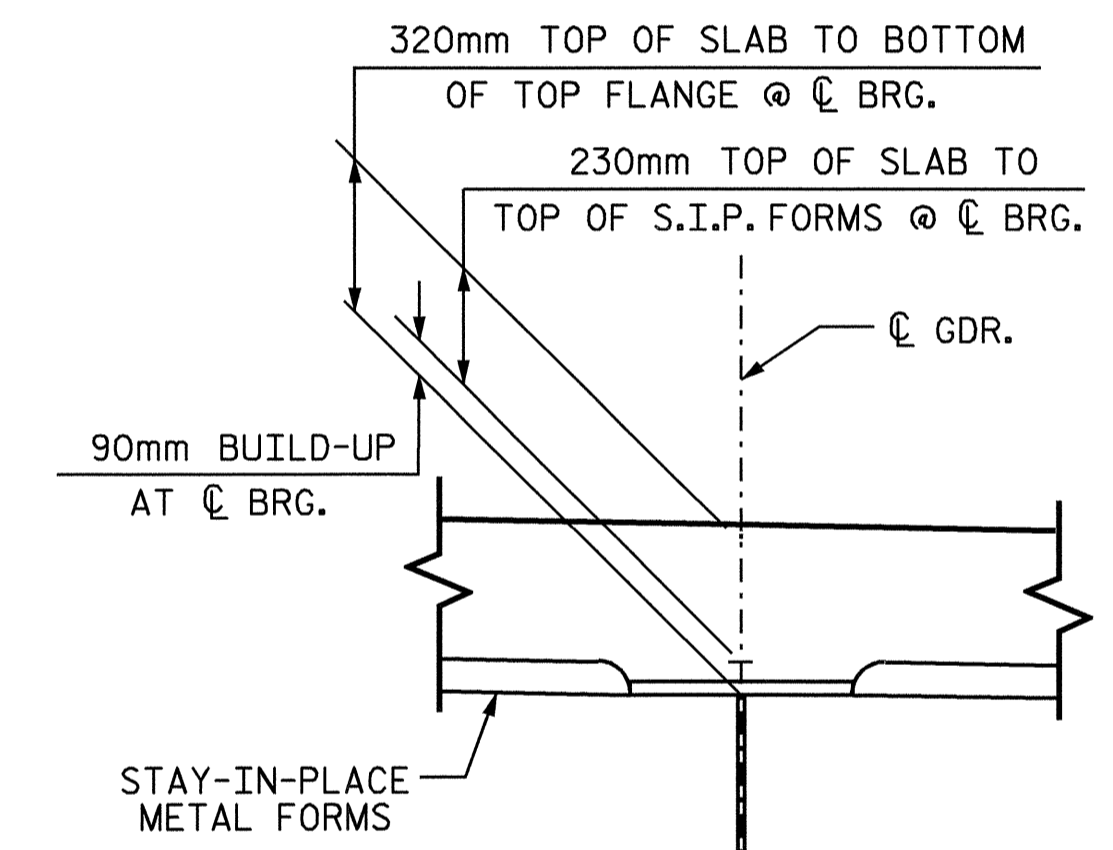

DETAIL A

PROJECT NO. R-0977A
 CHEROKEE COUNTY
 STATION: 24+60.500-LC1B-

SHEET 1 OF 2

STATE OF NORTH CAROLINA
 DEPARTMENT OF TRANSPORTATION
 RALEIGH
 SUPERSTRUCTURE
 TYPICAL SECTIONS
 SPANS A & B

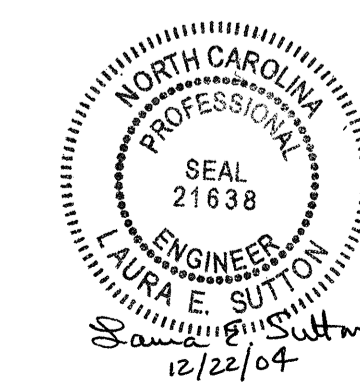

| REVISIONS | | | | | | SHEET NO. |
|-----------|-----|-------|-----|-----|-------|--------------|
| NO. | BY: | DATE: | NO. | BY: | DATE: | S-82 |
| 1 | | | 3 | | | TOTAL SHEETS |
| 2 | | | 4 | | | 230 |

DRAWN BY: B.N.BARODAWALA DATE: 10-9-03
 CHECKED BY: MIKE ALLEN DATE: 10-04