

TYPICAL SECTION

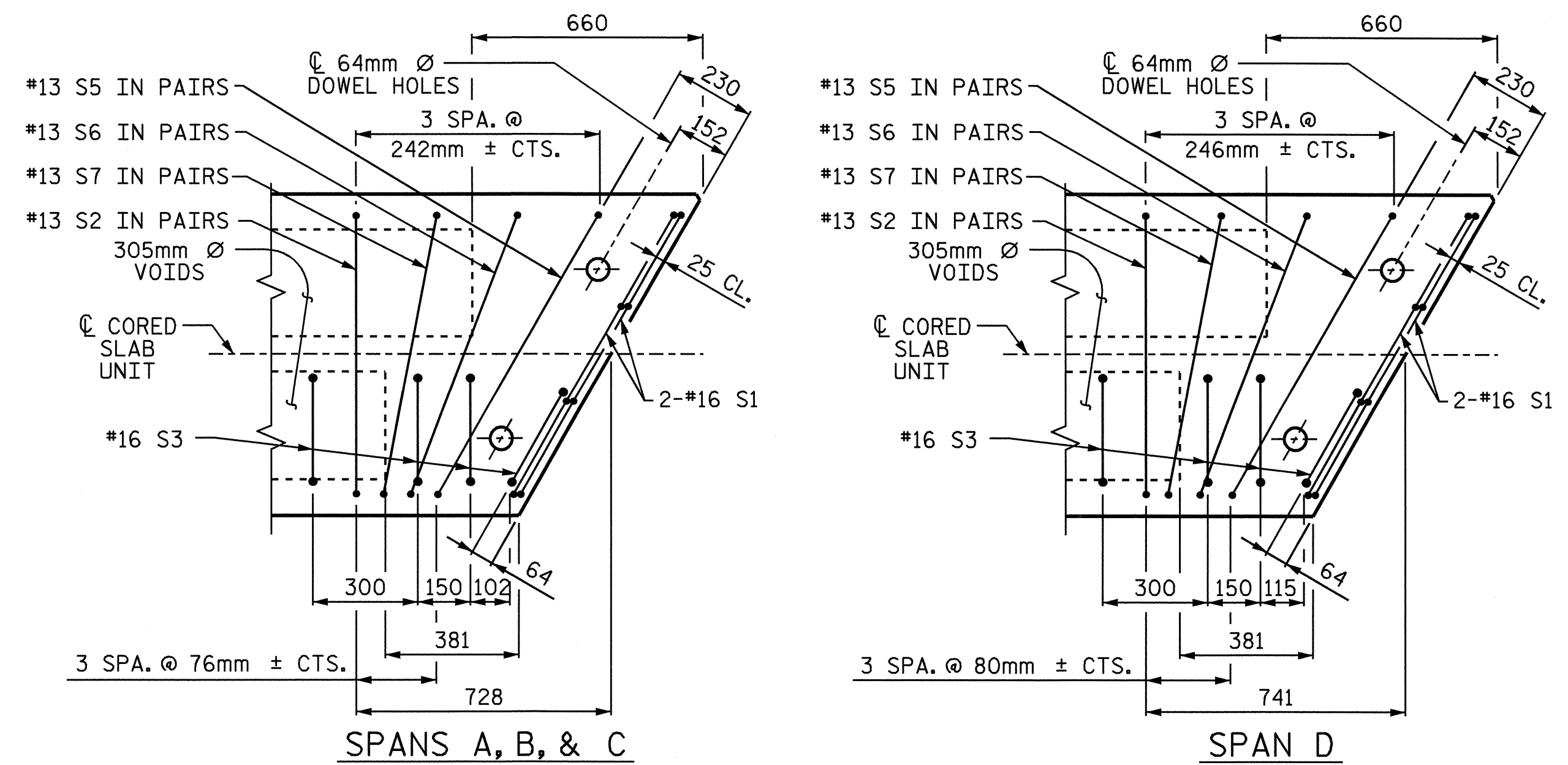

PART PLAN-EXTERIOR SECTION

NOTE: EXTERIOR SECTION SHOWN-INTERIOR SECTION SIMILAR EXCEPT OMIT S3 BARS.

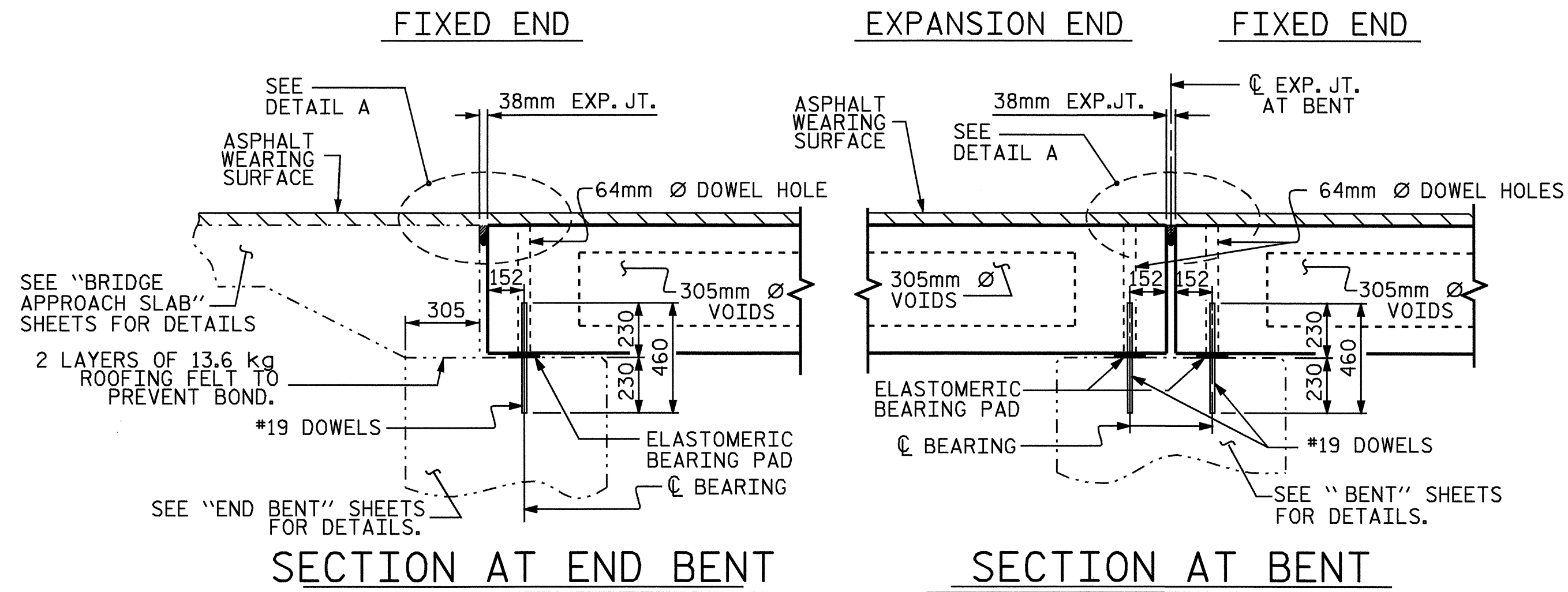

SECTION AT END BENT

SECTION AT BENT

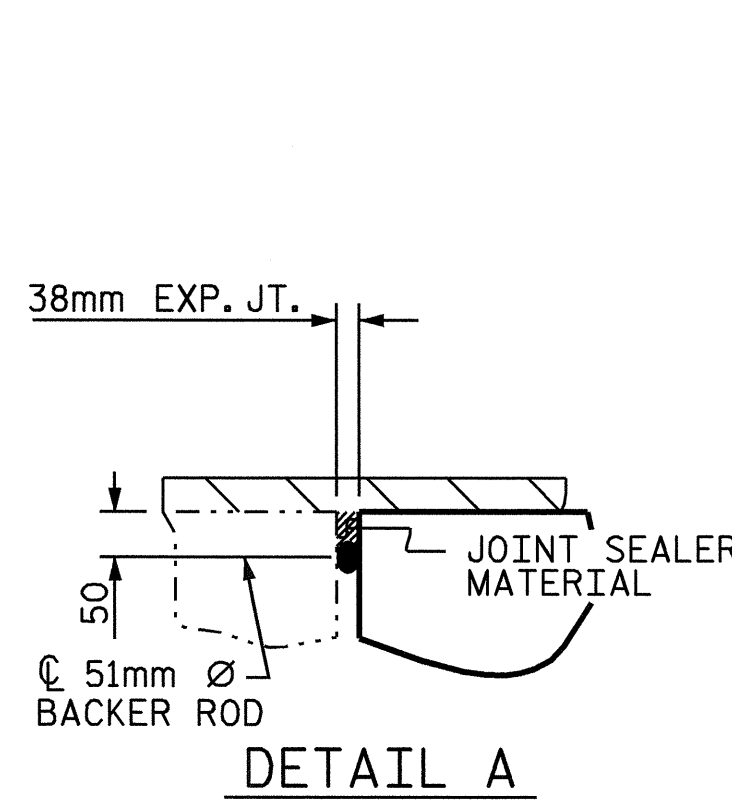

DETAIL A

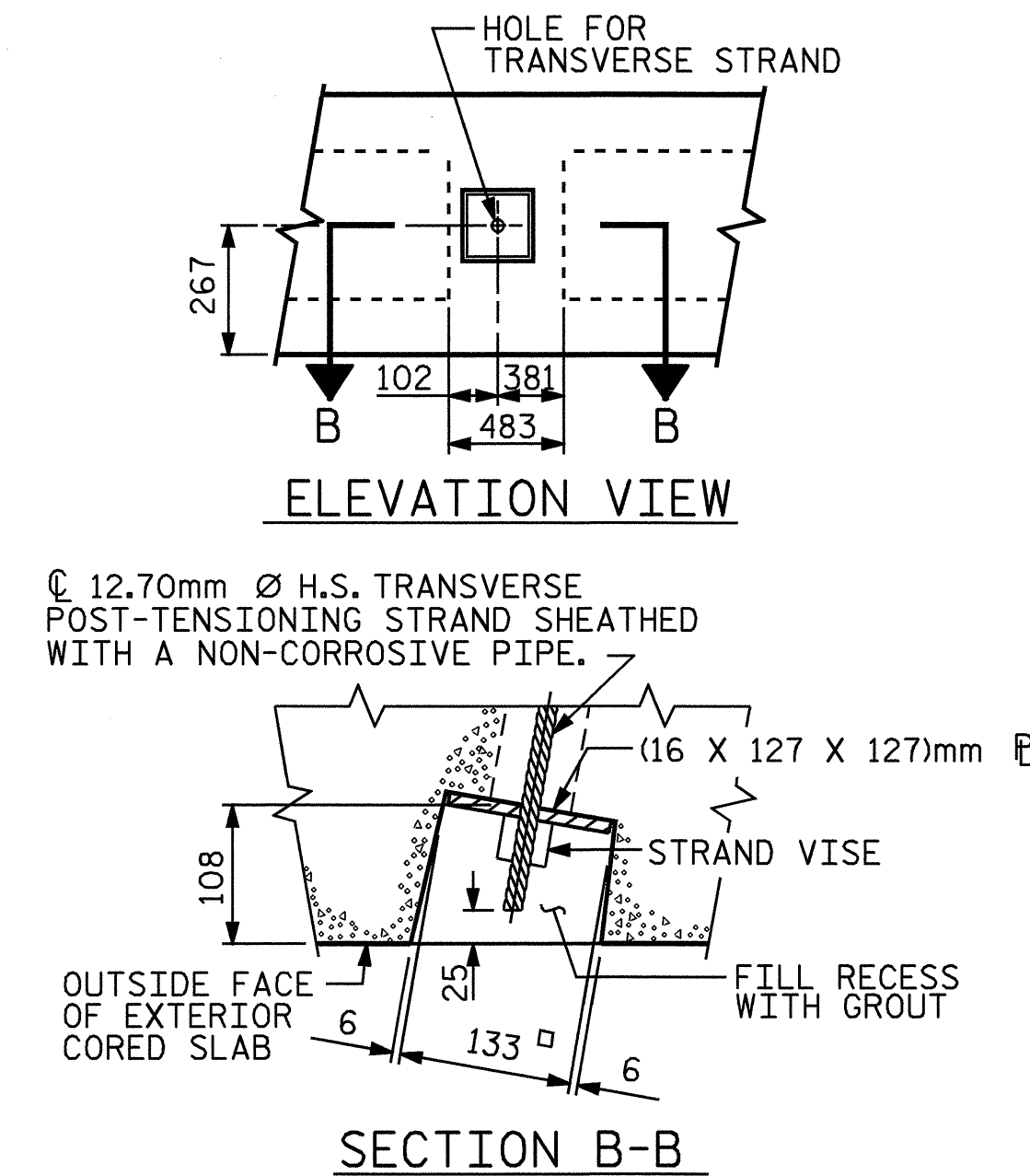

ELEVATION VIEW

SECTION B-B

GROUTED RECESS AT END OF POST-TENSIONED STRAND

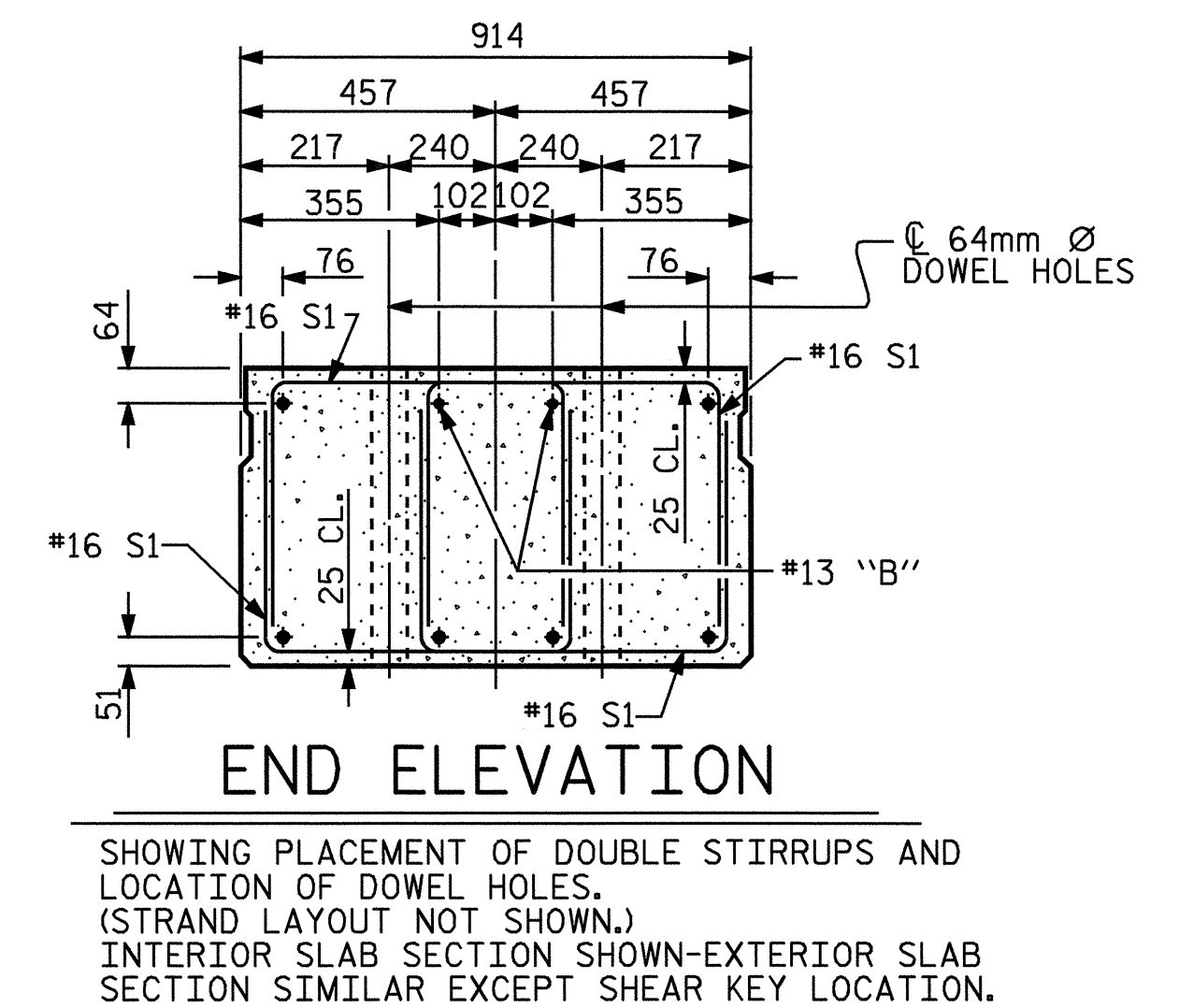

END ELEVATION

SHOWING PLACEMENT OF DOUBLE STIRRUPS AND LOCATION OF DOWEL HOLES. (STRAND LAYOUT NOT SHOWN.) INTERIOR SLAB SECTION SHOWN-EXTERIOR SLAB SECTION SIMILAR EXCEPT SHEAR KEY LOCATION.

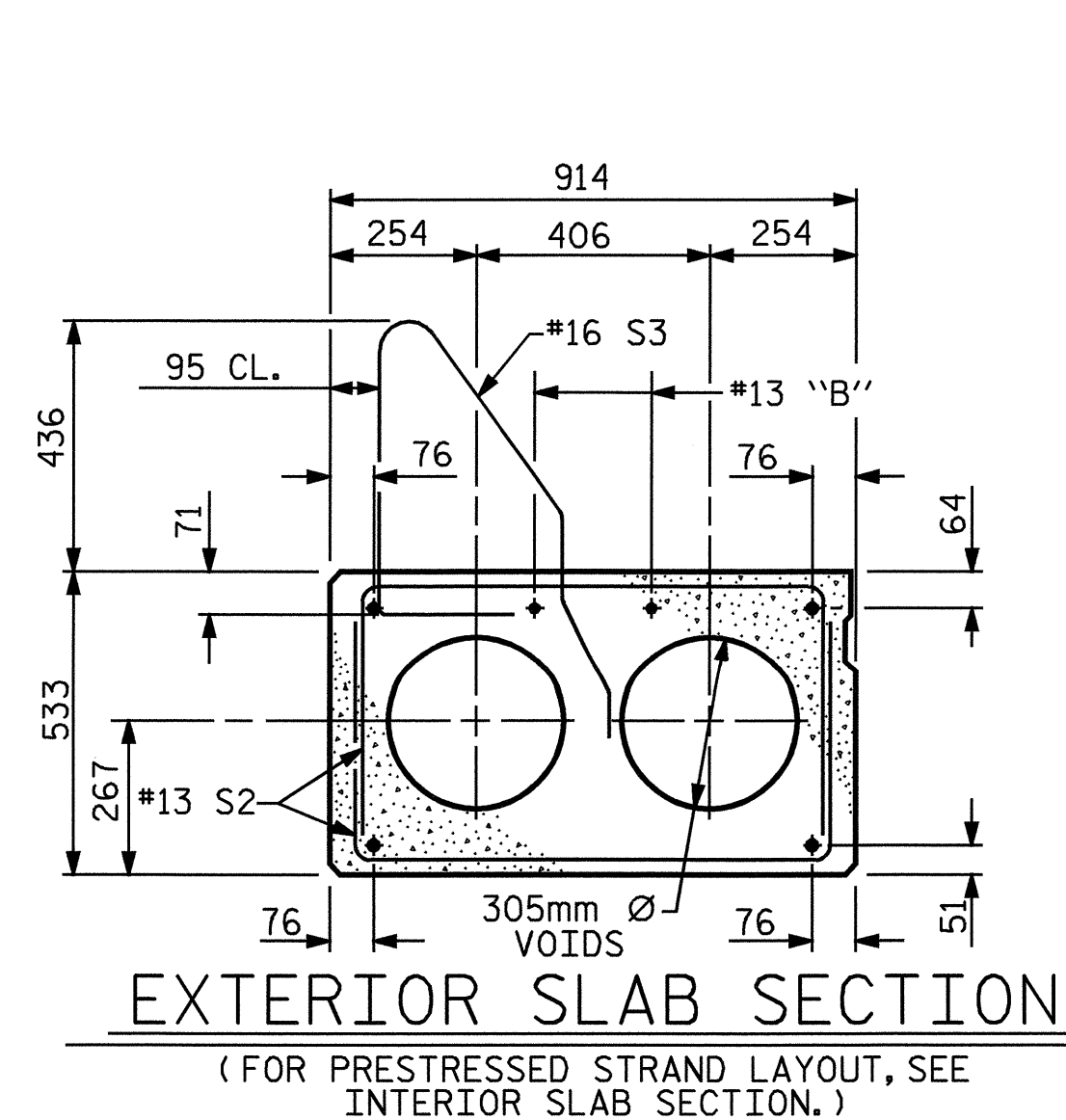

EXTERIOR SLAB SECTION

(FOR PRESTRESSED STRAND LAYOUT, SEE INTERIOR SLAB SECTION.)

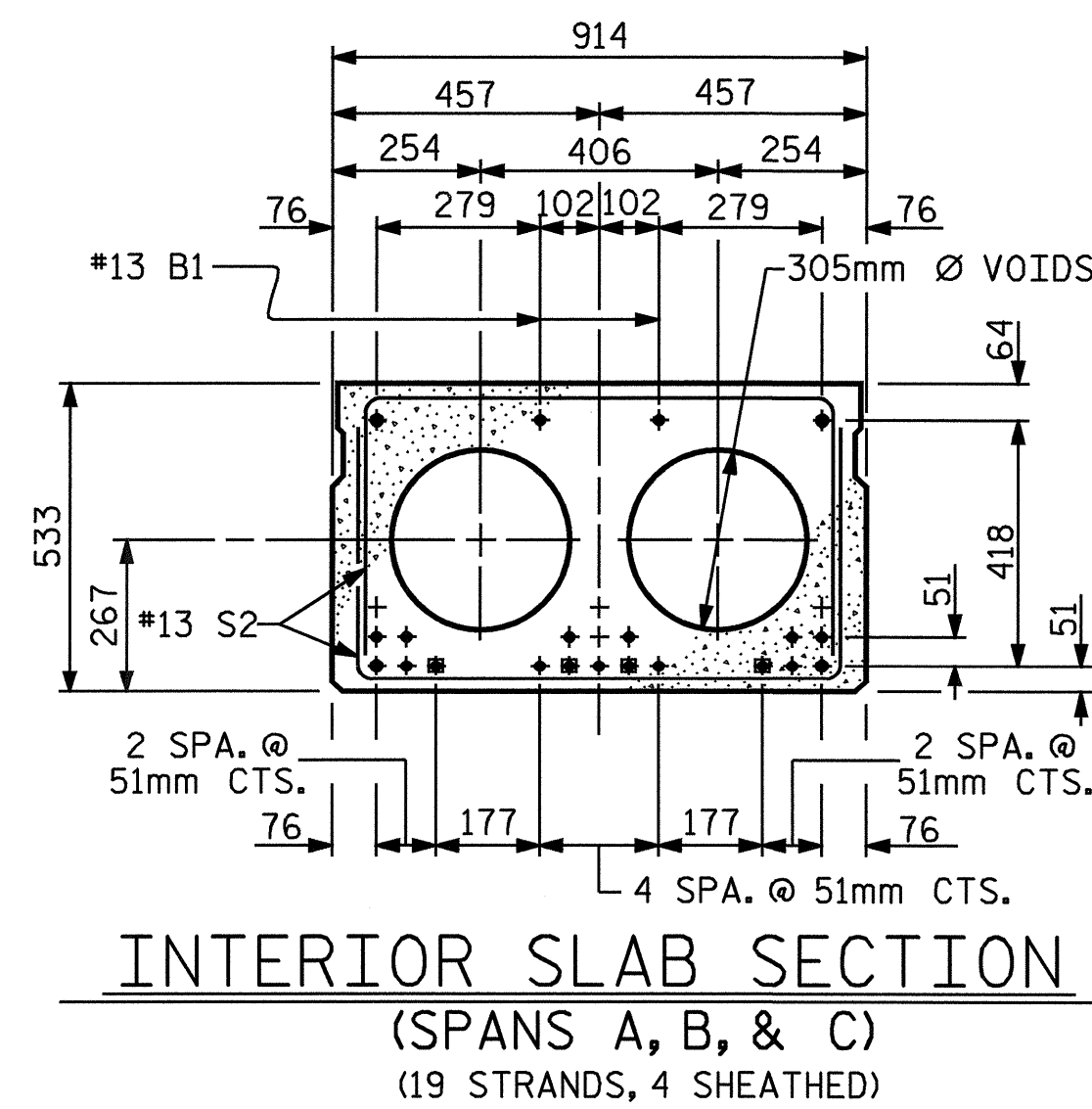

INTERIOR SLAB SECTION (SPANS A, B, & C)

(19 STRANDS, 4 SHEATHED)

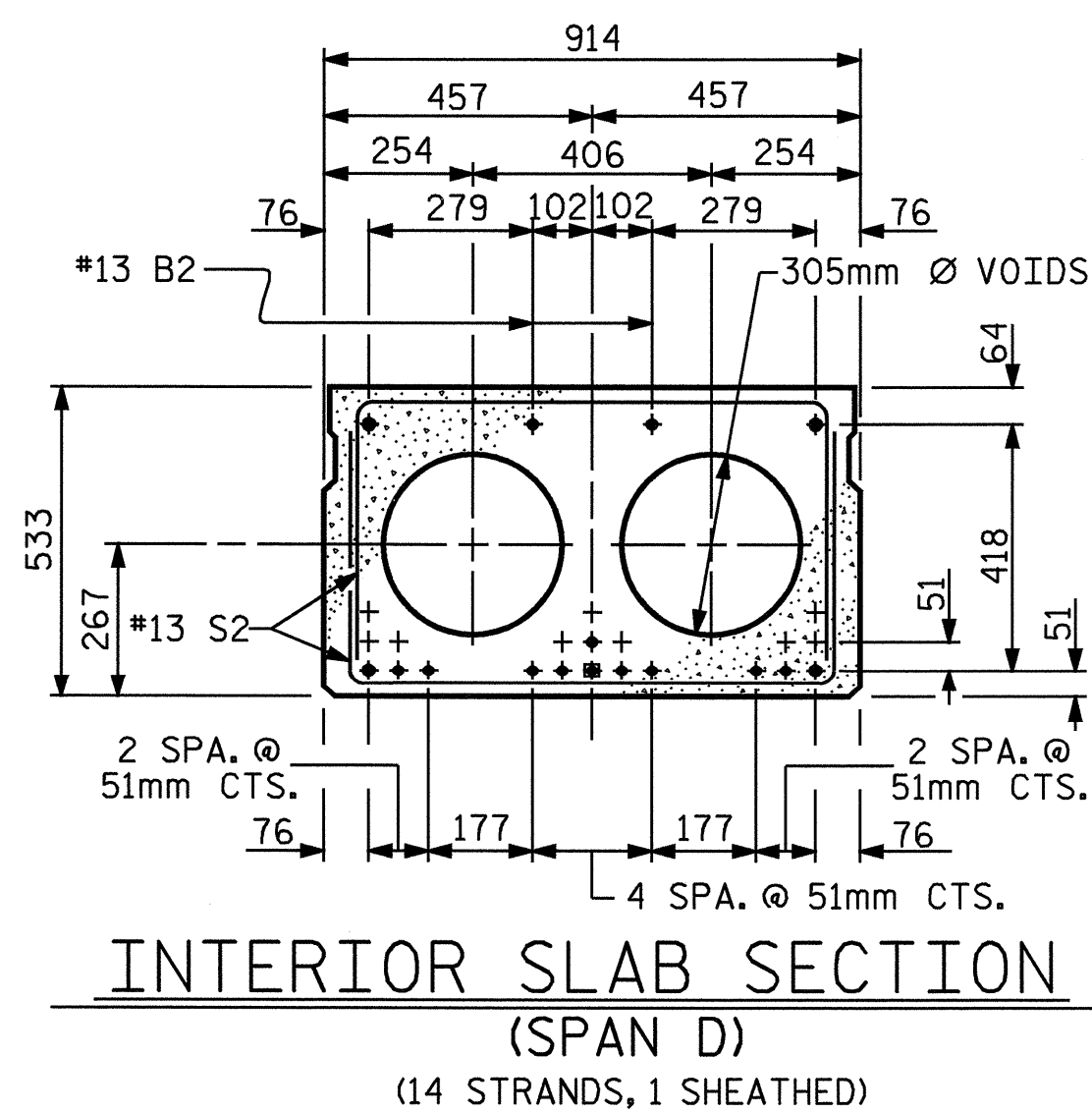

INTERIOR SLAB SECTION (SPAN D)

(14 STRANDS, 1 SHEATHED)

12.70mm Ø LOW RELAXATION STRAND LAYOUT

BOND SHALL BE BROKEN ON THESE STRANDS FOR A DISTANCE OF 1.220m FROM END OF CORED SLAB UNIT, SEE STANDARD SPECIFICATIONS ARTICLE 1078-7.

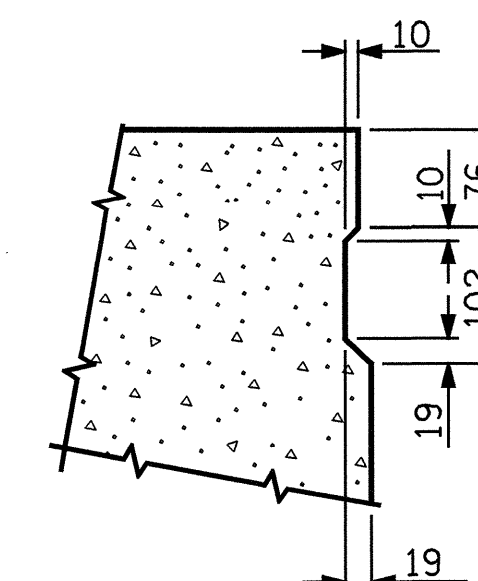

SHEAR KEY DETAIL

NOTE: OMIT SHEAR KEY ON OUTSIDE FACE OF EXTERIOR CORED SLABS.

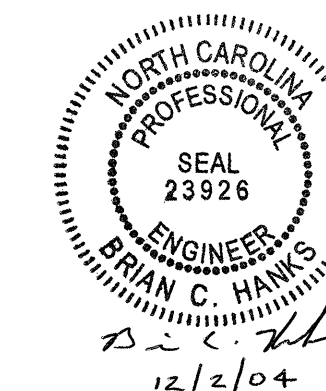

PROJECT NO. B-3266  
WILKES COUNTY  
STATION: 12+48.000 -L-

STATE OF NORTH CAROLINA DEPARTMENT OF TRANSPORTATION RALEIGH						SHEET NO.
SUPERSTRUCTURE 914mm X 533mm PRESTRESSED CONCRETE CORED SLAB UNIT						S-4
REVISIONS						TOTAL SHEETS
NO.	BY:	DATE:	NO.	BY:	DATE:	26
1			3			
2			4			

DRAWN BY: William J. Parker DATE: 01/15/04  
CHECKED BY: A.B. NAIK DATE: 4/27/04