

### NOTES

STIRRUPS IN CAP MAY BE SHIFTED AS NECESSARY TO CLEAR #19 D1 DOWELS.

THE CONTRACTOR SHALL PROVIDE FOR INSTALLATION OF THE 102mm DIAMETER DRAIN PIPE THROUGH THE WING WALL AS REQUIRED FOR REINFORCED BRIDGE APPROACH FILLS, SEE THE ROADWAY PLANS. REINFORCING STEEL IN THE WING WALL MAY BE SHIFTED AS NECESSARY TO CLEAR THE DRAIN PIPE.

THE LATERAL GUIDE AT EACH END OF THE CAP IS NOT TO BE POURED UNTIL AFTER THE CORED SLAB UNITS ARE IN PLACE.

FOR PILE SPLICE DETAILS, SEE SHEET 2 OF 2.

FOR TEMPORARY DRAINAGE DETAILS, SEE SHEET 2 OF 2.

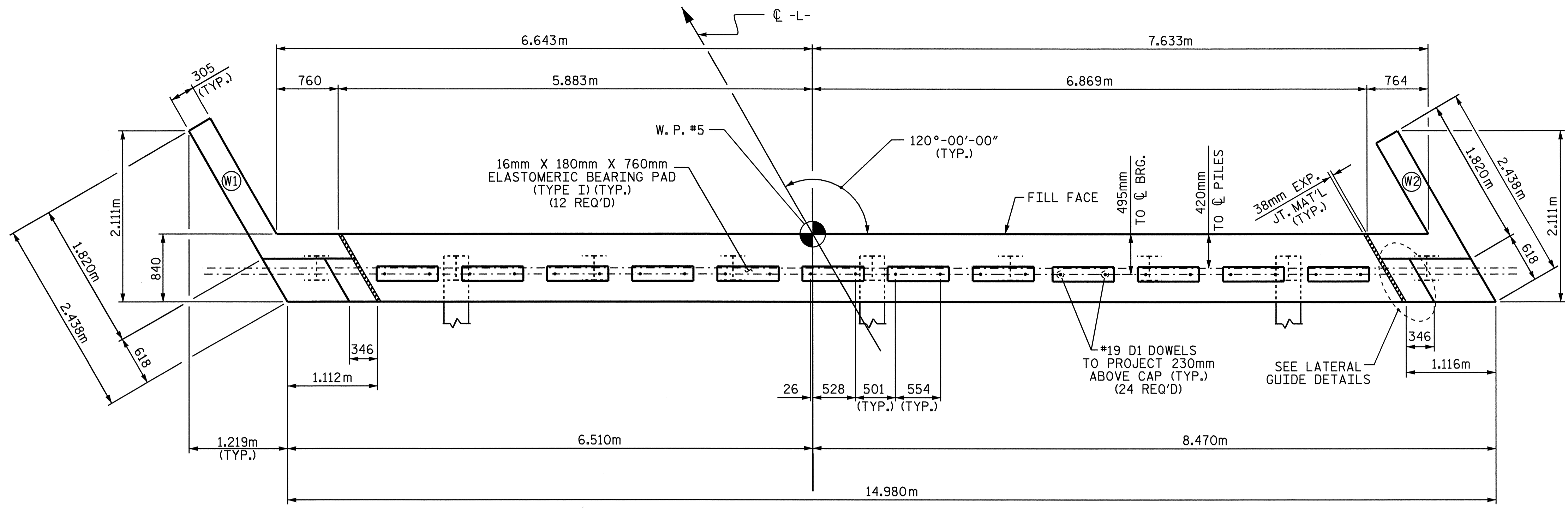

PLAN

TOP OF PILE ELEVATIONS	
P1	389.920
P2	389.891
P3	389.862
P4	389.832
P5	389.803
P6	389.774
P7	389.745
P8	389.715
P9	389.686

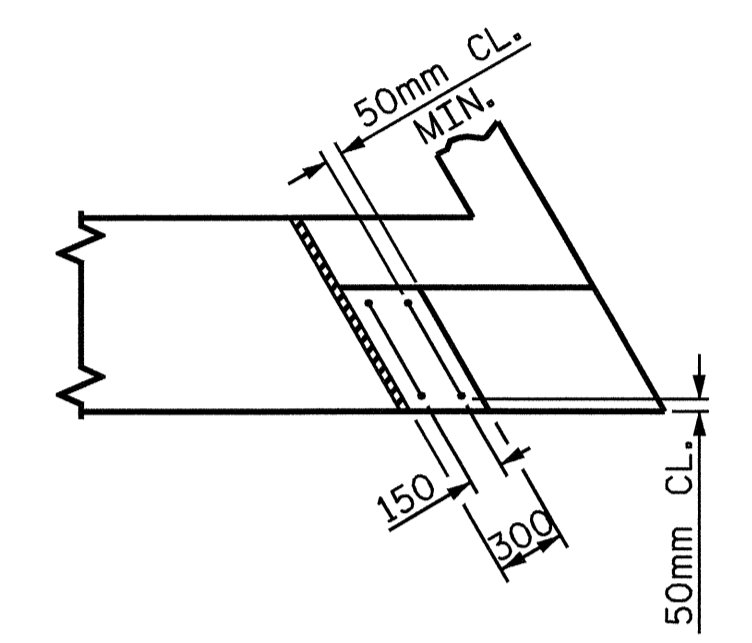

PLAN

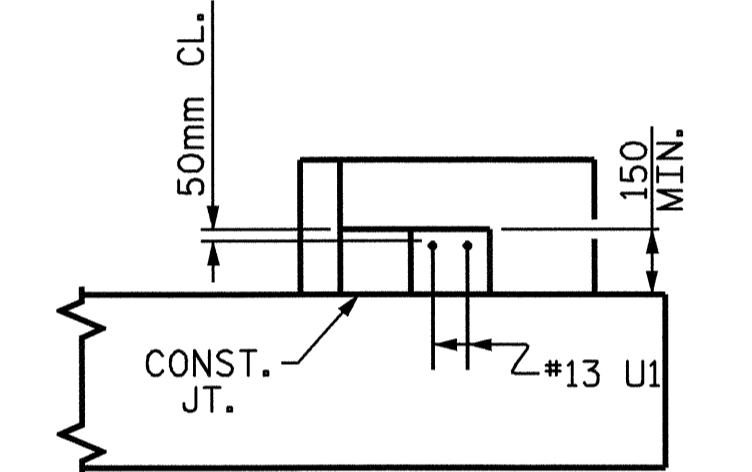

ELEVATION

### LATERAL GUIDE

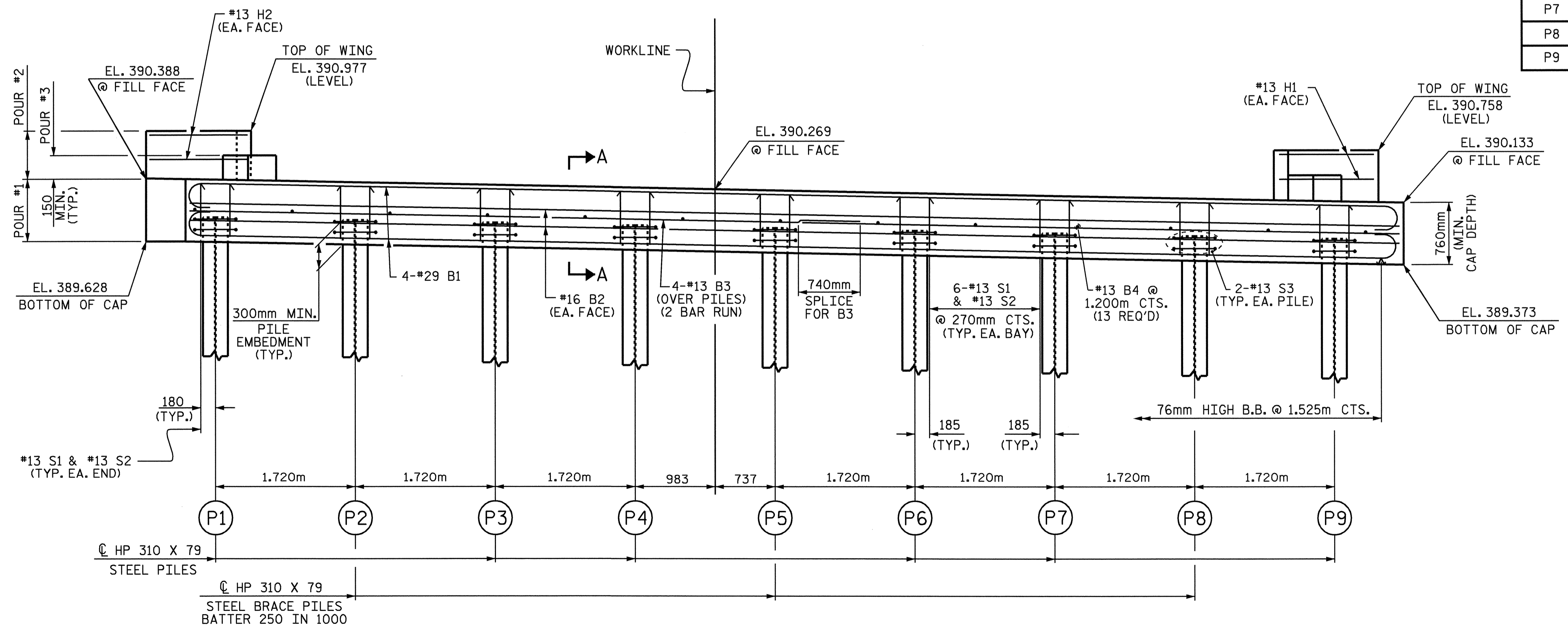

ELEVATION

(WINGS NOT SHOWN FOR CLARITY)

PROJECT NO. B-3266  
WILKES COUNTY  
 STATION: 12+48.000 -L-

SHEET 1 OF 2

STATE OF NORTH CAROLINA  
 DEPARTMENT OF TRANSPORTATION  
 RALEIGH

### SUBSTRUCTURE END BENT 2

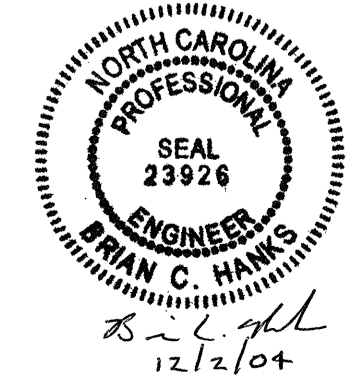

REVISIONS						SHEET NO.
NO.	BY:	DATE:	NO.	BY:	DATE:	S-20
1			3			TOTAL SHEETS
2			4			26

DRAWN BY: J.L. WALTON DATE: 6/16/04  
 CHECKED BY: D.G. ELY DATE: 7/30/04