

NOTES :
FOR BERM WIDTH DIMENSIONS,SEE GENERAL DRAWING.

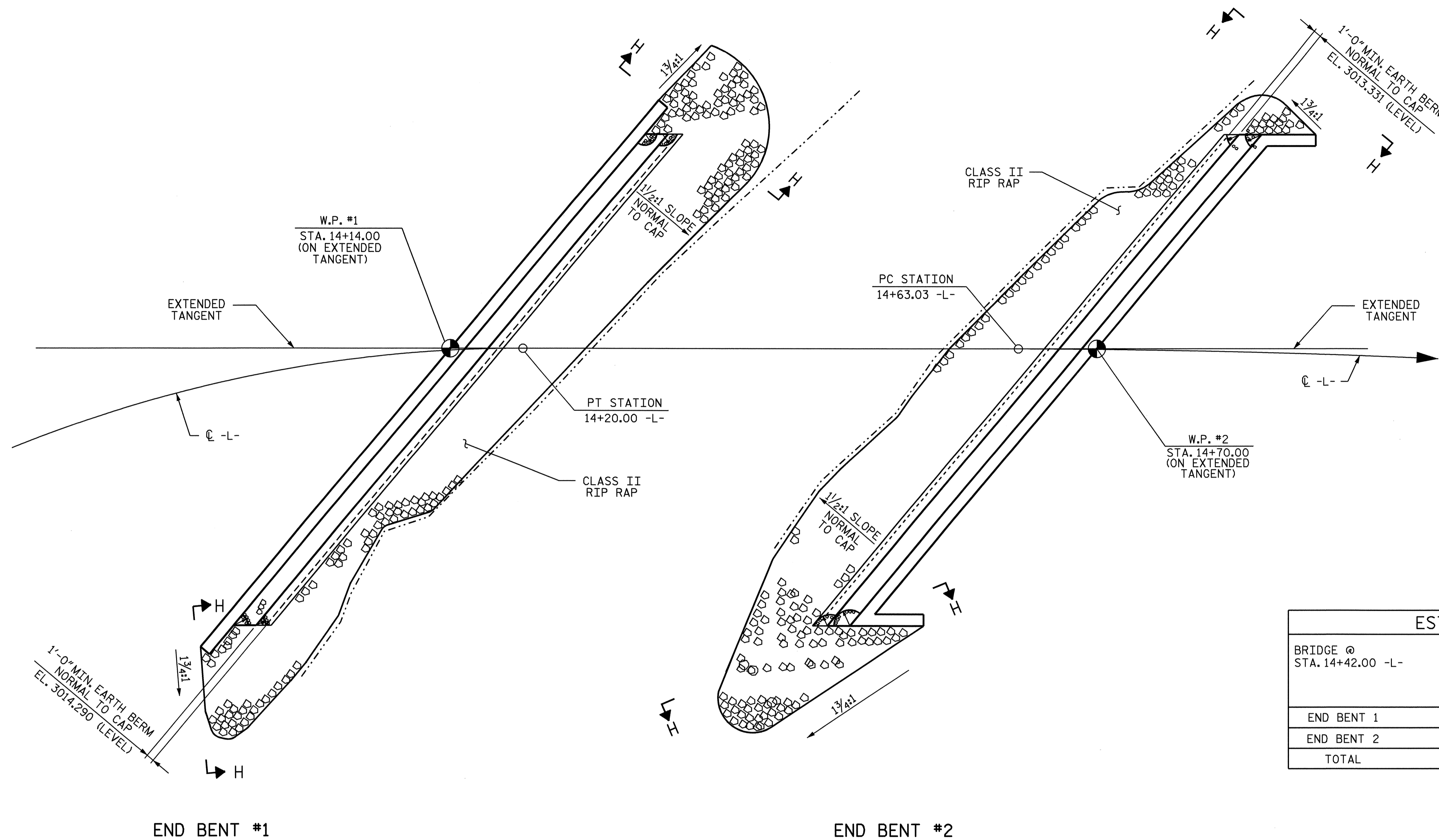

ESTIMATED QUANTITIES		
BRIDGE @ STA. 14+42.00 -L-	PLAIN RIP RAP CLASS II	FILTER FABRIC FOR DRAINAGE
	TONS	SQUARE YARDS
END BENT 1	120	130
END BENT 2	100	110
TOTAL	220	240

END BENT #1

END BENT #2

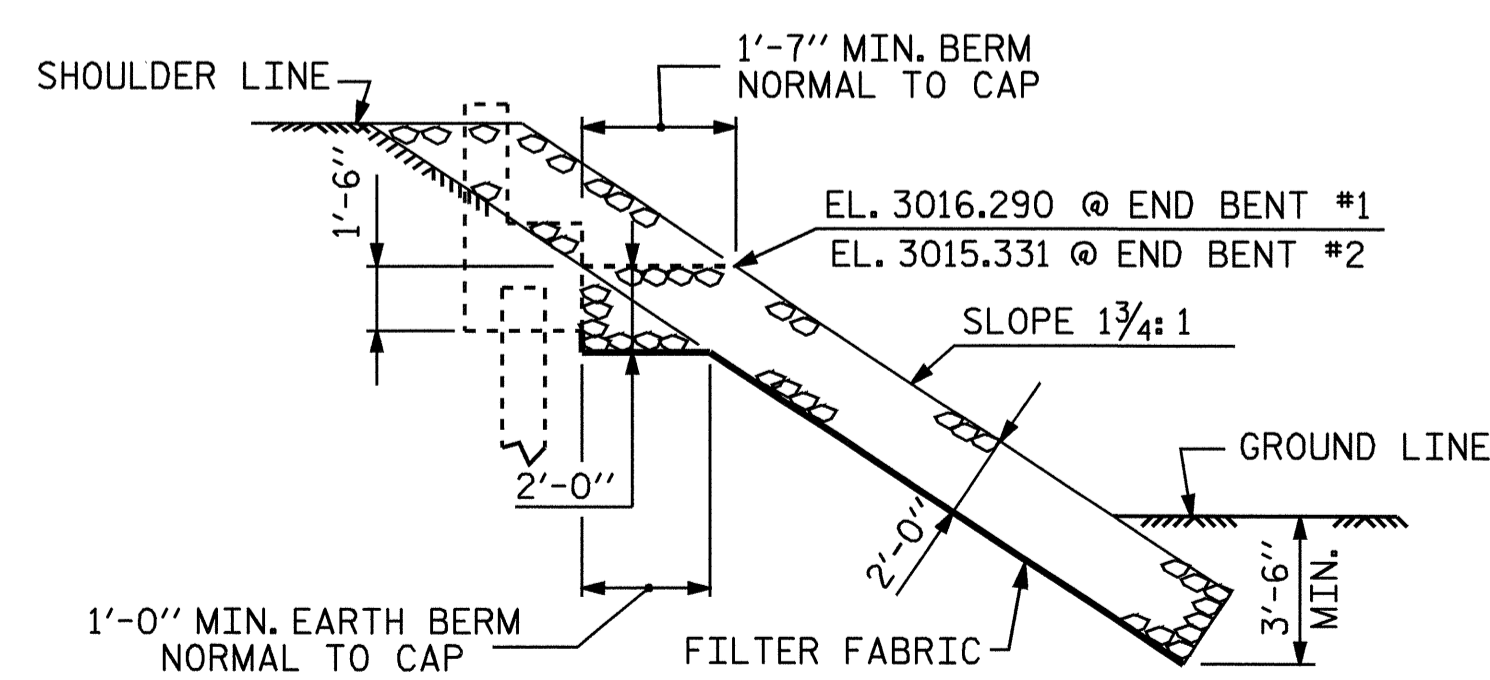

SECTION H-H

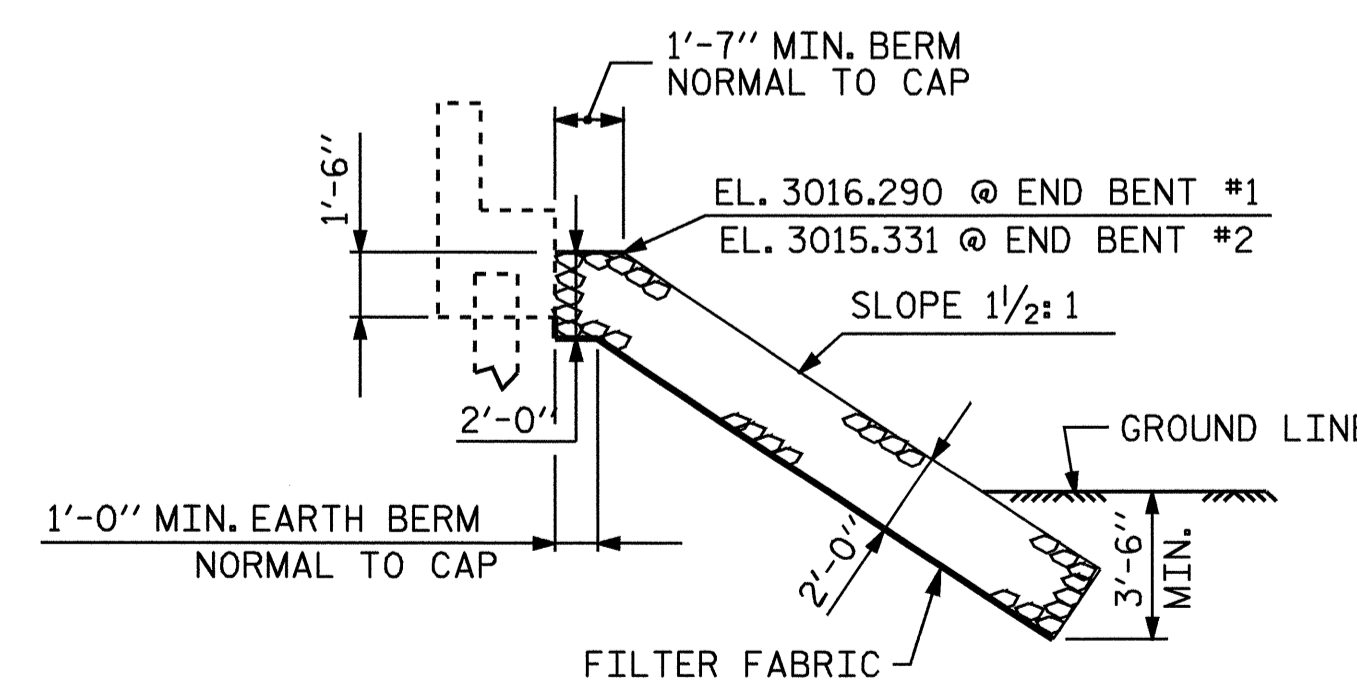

SECTION
BERM RIP RAPPED

PROJECT NO. B-3659
HAYWOOD COUNTY
STATION: 14+42.00 -L-

STATE OF NORTH CAROLINA
DEPARTMENT OF TRANSPORTATION
RALEIGH

RIP RAP DETAILS



DRAWN BY : D. G. ELY DATE : 02/16/04
CHECKED BY : A. B. NAIK DATE : 03/29/04

30-NOV-2004 15:00
W:\squadg\TURNED.IN\B3659\FINAL_PLANS\B3659_SD_SP_01.dgn
rwwr\ght

REVISIONS						SHEET NO.
NO.	BY:	DATE:	NO.	BY:	DATE:	S-20
1			3			TOTAL SHEETS
2			4			23