

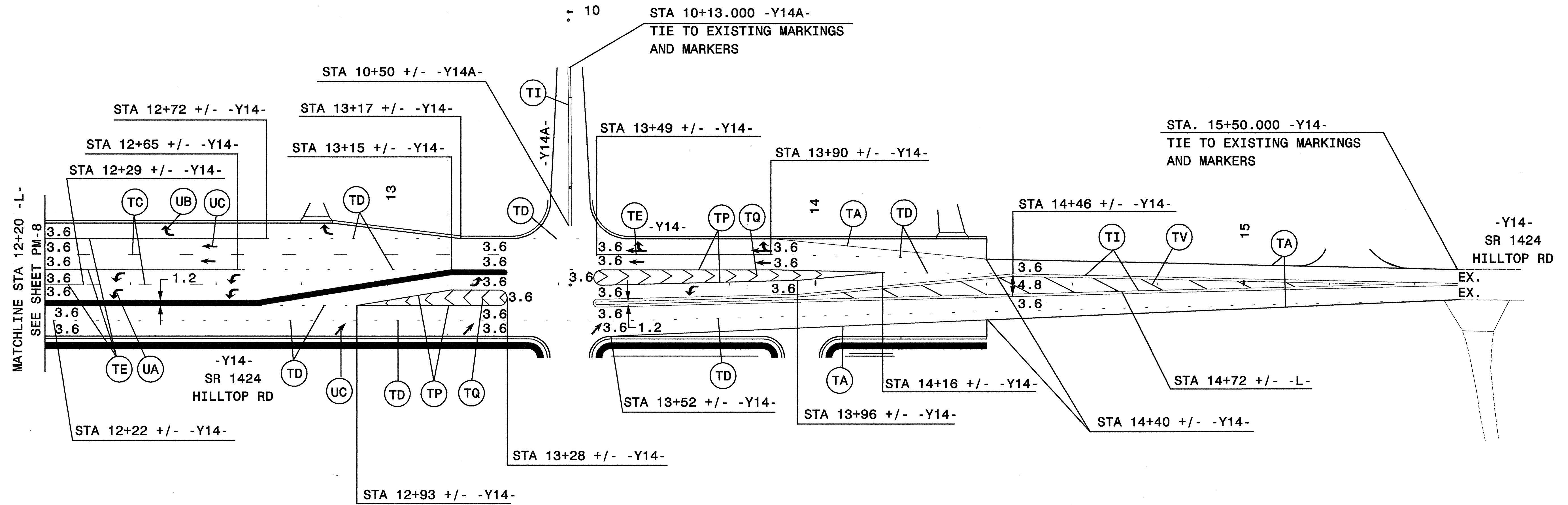

PROJ. REFERENCE NO.	SHEET NO.
U-2913B	PM-10

**GREENHORNE & O'MARA, INC.**  
 5565 CENTERVIEW DRIVE, SUITE 107  
 RALEIGH, NORTH CAROLINA 27606  
 (919) 851-1919

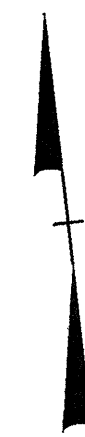

- NOTES:**
- 1) SEE SHEET PM-1 FOR FINAL PAVEMENT MARKING SCHEDULE.
  - 2) REFER TO RSD 1250.01, 1251.01, AND 1253.01 FOR PLACEMENT OF FINAL PAVEMENT MARKERS.
  - 3) PAVEMENT MARKINGS TO BE MARKED ACCORDING TO ROADWAY STANDARD DRAWINGS UNLESS OTHERWISE NOTED IN PLANS.

APPROVED: <i>Donna C. Keener</i> DATE: 9/14/04	<b>FINAL PAVEMENT MARKING PLAN</b>			
	SCALE: NONE			
	DATE: 9/14/04			
	DWG. BY: JSB/JAP			
	DESIGN BY: JAP			
REVIEWED BY: PMW	REVISIONS	<table border="1"> <tr> <td>CADD FILE</td> <td>PM10.DGN</td> </tr> </table>	CADD FILE	PM10.DGN
CADD FILE	PM10.DGN			

\$\$\$\$\$SYTIME\$\$\$\$\$  
 \$\$\$\$\$\$DGN\$\$\$\$\$  
 \$\$\$\$\$\$USERNAME\$\$\$\$\$