

NOTES

STIRRUPS AND "U" BARS IN CAP MAY BE SHIFTED AS NECESSARY TO CLEAR ANCHOR BOLTS.

HOOKS ON "V" BARS MAY BE TURNED AS NECESSARY FOR PLACING REINFORCING STEEL.

THE CONTRACTOR'S ATTENTION IS CALLED TO THE FACT THAT THE LONGITUDINAL REINFORCEMENT FOR THE DRILLED PIERS IS DETAILED WITH 3 FEET OF EXTRA LENGTH.

ALL STEEL IN THE DRILLED PIERS IS INCLUDED IN THE PAY ITEMS FOR "REINFORCING STEEL" AND "SPIRAL COLUMN REINFORCING STEEL" OR "EPOXY COATED SPIRAL COLUMN REINFORCING STEEL".

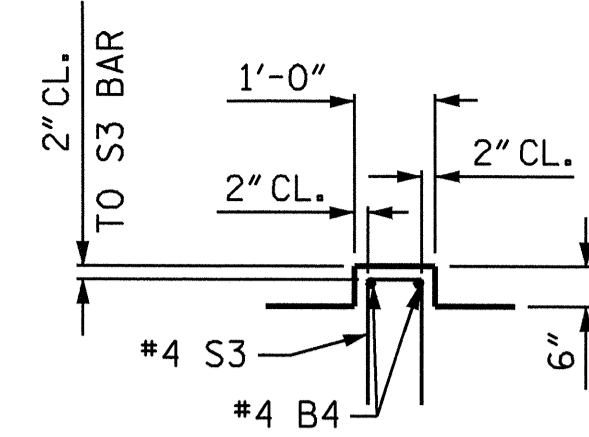

DETAIL 'B'
(TYP. EA. LATERAL GUIDE)

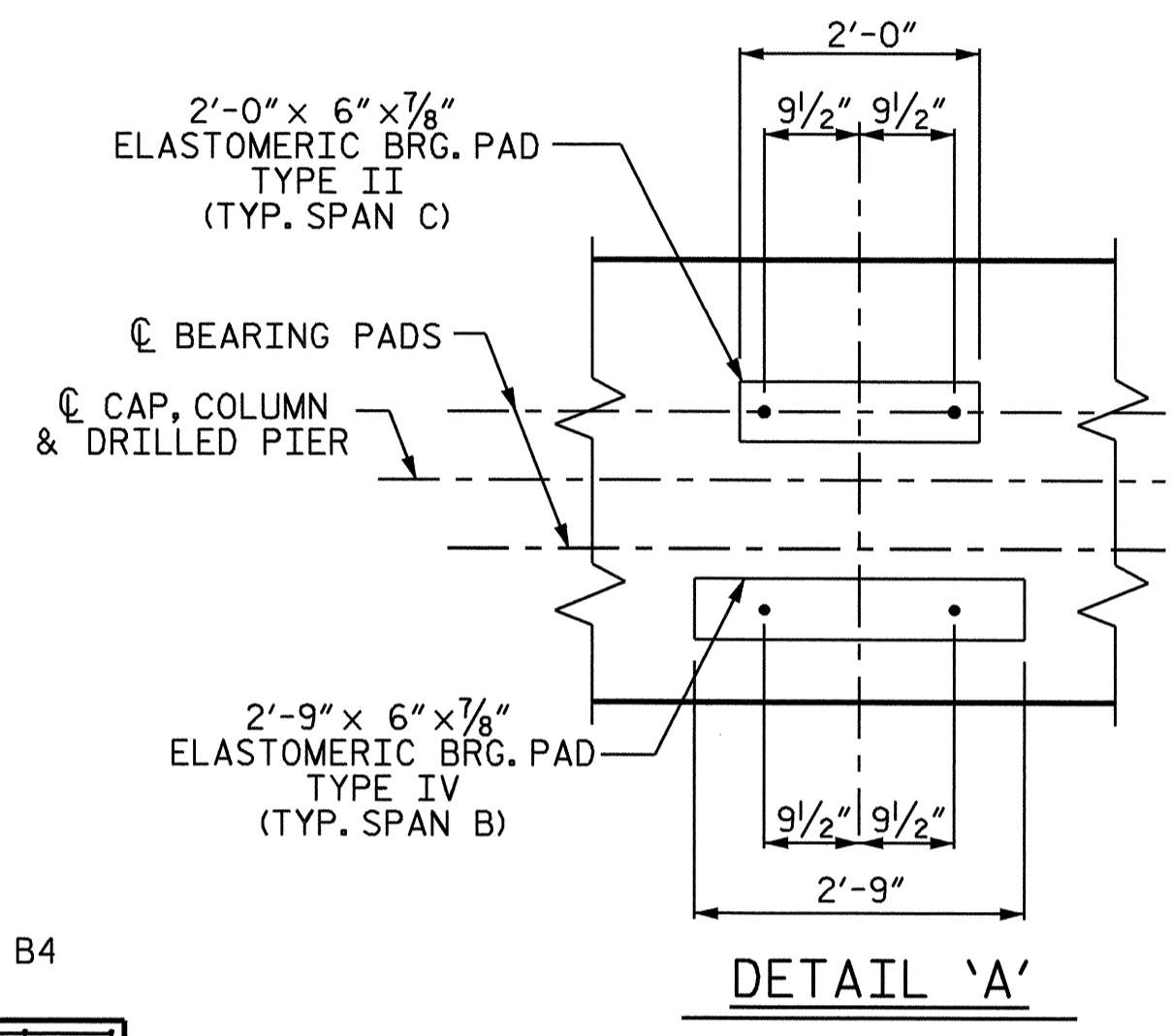

DETAIL 'A'

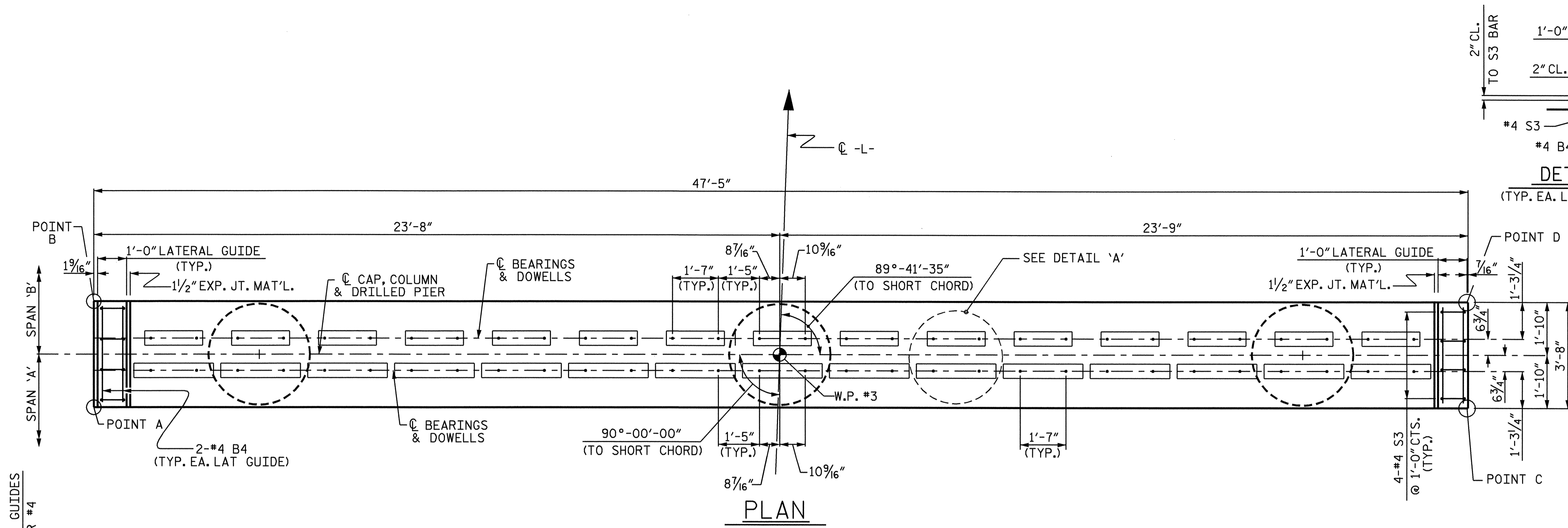

PLAN

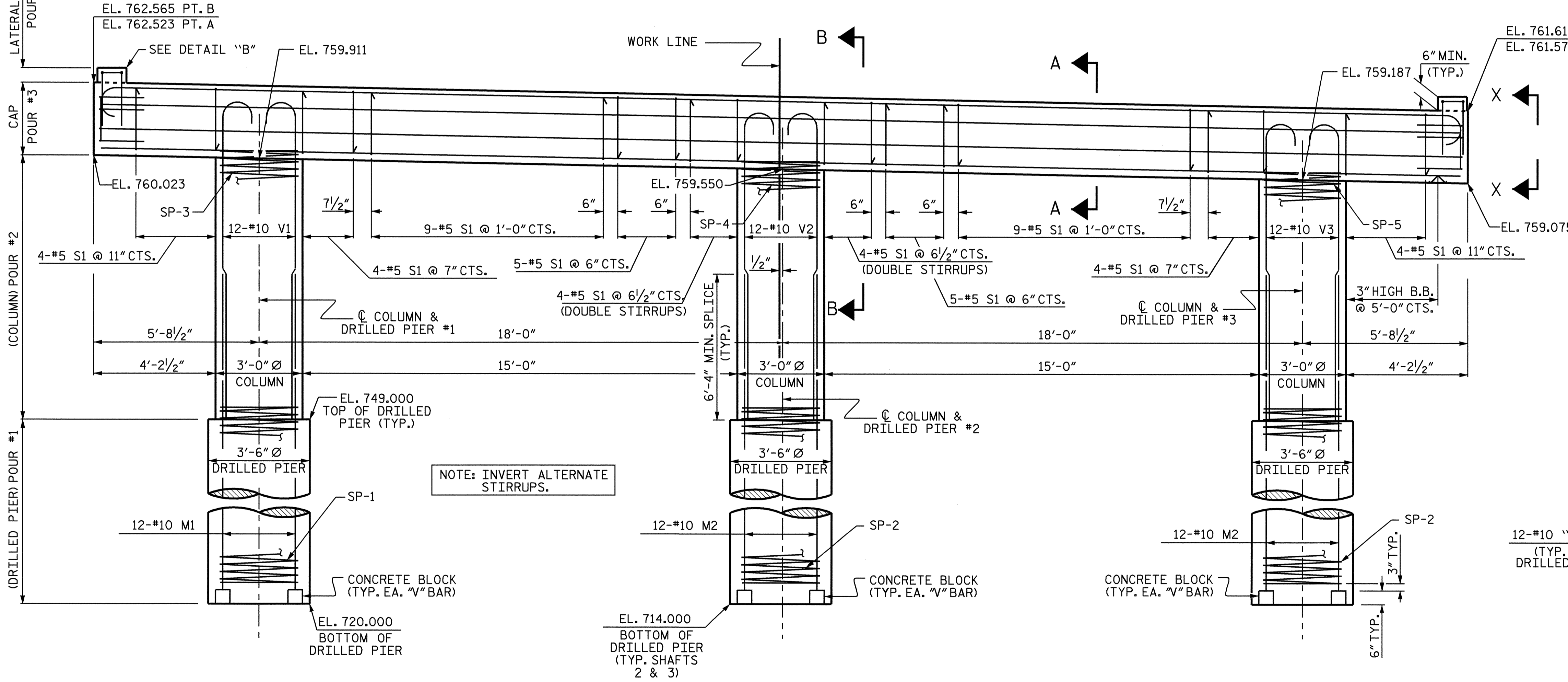

ELEVATION

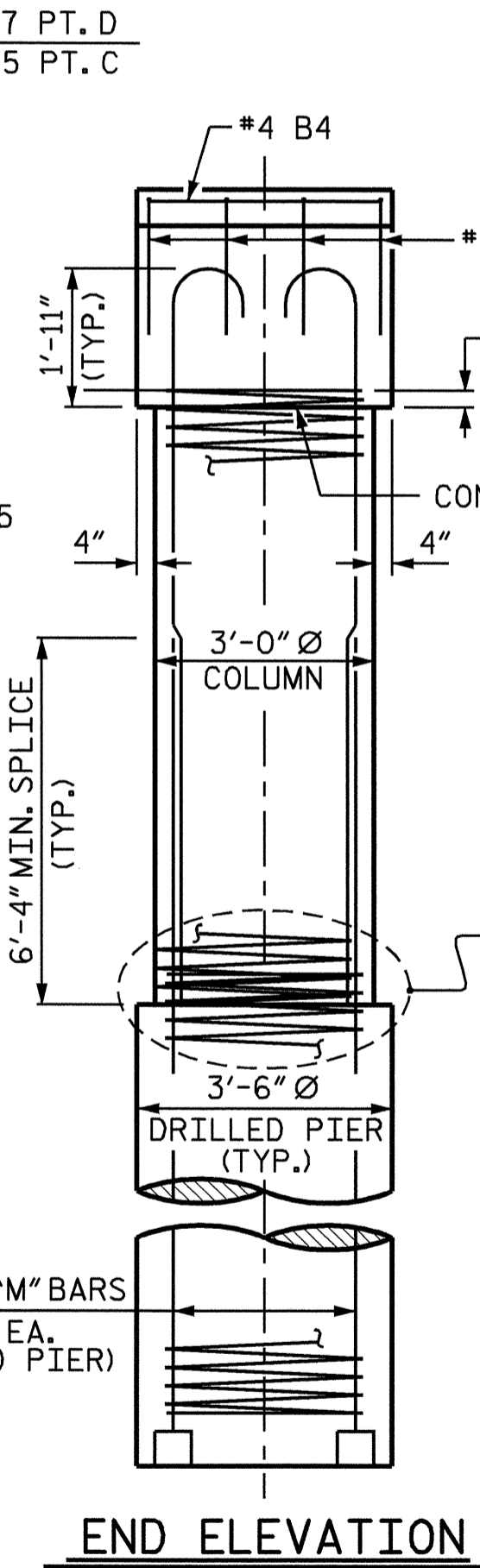

END ELEVATION

NOTE: INVERT ALTERNATE STIRRUPS.

PROJECT NO. B-3454
FORSYTH COUNTY
 STATION: 20+93.00 -L-

SHEET 1 OF 2

STATE OF NORTH CAROLINA
 DEPARTMENT OF TRANSPORTATION
 RALEIGH

SUBSTRUCTURE
BENT #2

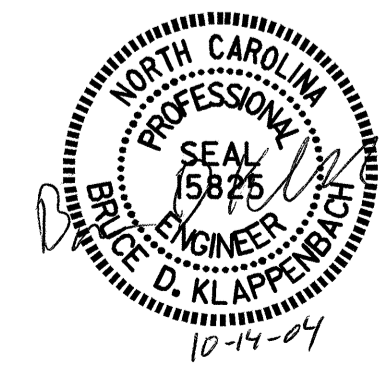

REVISIONS						SHEET NO.
NO.	BY:	DATE:	NO.	BY:	DATE:	5-18
1			3			TOTAL SHEETS
2			4			27

DRAWN BY : J.B. WILSON DATE : 9/29/04
 CHECKED BY : G.M. PATTERSON DATE : 9/04

14-OCT-2004 11:40
 W:\sqd\B3454\jwilson\Microstation\B-3454.sd_B*.02.dgn
 jwilson