

TOP OF FLOOR SLAB-'A' BAR LAYOUT

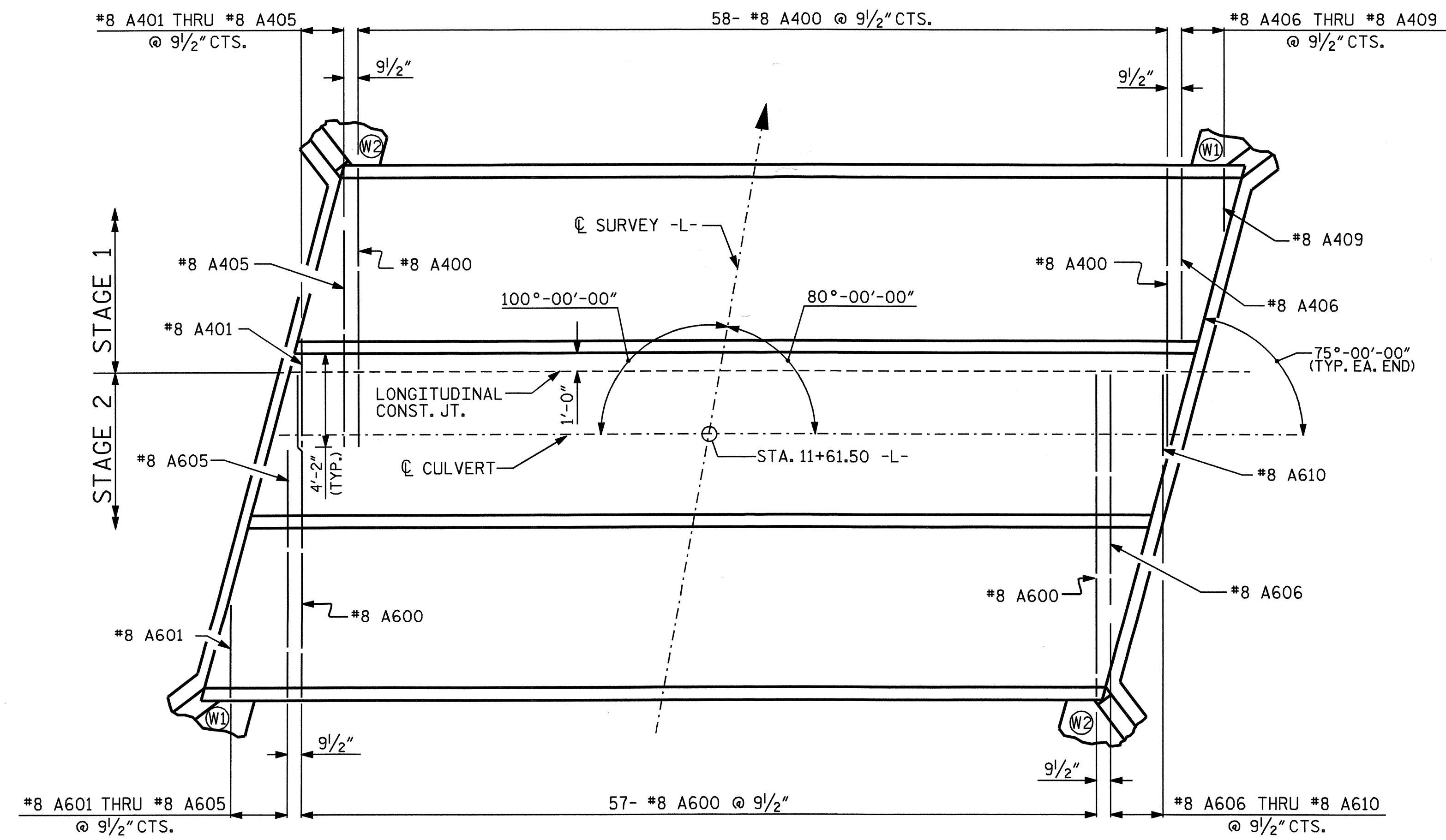

BOTTOM OF FLOOR SLAB-'A' BAR LAYOUT

REINFORCING STEEL

BAR	NO.	SIZE	TYPE	LENGTH	WEIGHT	BAR	NO.	SIZE	TYPE	LENGTH	WEIGHT
A100	68	6	STR	29'-4"	2996	A1	128	6	6	5'-10"	1121
A101	4	6	STR	24'-2"	145	A2	128	8	6	8'-9"	2990
A102	4	6	STR	19'-6"	117	B1	122	4	STR	9'-2"	747
A103	4	6	STR	14'-10"	89	B2	128	4	STR	7'-4"	627
A104	4	6	STR	10'-2"	61	B3	268	5	STR	9'-2"	2562
A105	4	6	STR	5'-6"	33	C1	216	4	STR	26'-0"	3752
A200	79	4	STR	13'-2"	695	D1	6	6	STR	1'-10"	17
A201	1	4	STR	3'-11"	3	D2	3	6	STR	1'-4"	6
A202	2	4	STR	6'-1"	8	G1	8	5	STR	30'-5"	254
A203	2	4	STR	10'-5"	14	S1	3	8	STR	15'-9"	126
A204	2	4	STR	10'-4"	14	S2	6	8	STR	30'-5"	487
A205	2	4	STR	5'-11"	8	S3	3	8	STR	18'-8"	150
A206	2	4	STR	1'-7"	2	REINFORCING STEEL 28572 LBS.					
A300	54	8	STR	29'-4"	4229	SPLICE LENGTH CHART					
A301	2	8	STR	25'-11"	138	BAR	SIZE	SPLICE LENGTH			
A302	2	8	STR	22'-11"	122	A200, A500	#4	1'-9"			
A303	2	8	STR	20'-0"	107	A400, A600	#8	4'-0"			
A304	2	8	STR	17'-0"	91	B1	#4	1'-9"			
A305	2	8	STR	14'-1"	75	B3	#5	1'-9"			
A306	2	8	STR	11'-2"	60	C4	#4	1'-11"			
A307	2	8	STR	8'-2"	44	S1	#8	4'-0"			
A308	2	8	STR	5'-3"	28						
A309	2	8	STR	2'-3"	12						
A400	58	8	STR	15'-5"	2387						
A401	1	8	STR	3'-0"	8						
A402	1	8	STR	5'-11"	16						
A403	1	8	STR	8'-11"	24						
A404	1	8	STR	11'-10"	32						
A405	1	8	STR	14'-10"	40						
A406	1	8	STR	12'-4"	33						
A407	1	8	STR	9'-4"	25						
A408	1	8	STR	6'-5"	17						
A409	1	8	STR	3'-5"	9						
A500	78	4	STR	18'-1"	942						
A501	1	4	STR	2'-9"	2						
A502	2	4	STR	4'-11"	7						
A503	2	4	STR	9'-4"	12						
A504	2	4	STR	13'-8"	18						
A505	2	4	STR	14'-2"	19						
A506	2	4	STR	9'-10"	13						
A507	2	4	STR	5'-6"	7						
A508	1	4	STR	3'-4"	2						
A600	57	8	STR	18'-1"	2752						
A601	1	8	STR	5'-1"	14						
A602	1	8	STR	8'-0"	21						
A603	1	8	STR	11'-0"	29						
A604	1	8	STR	13'-11"	37						
A605	1	8	STR	16'-11"	45						
A606	1	8	STR	15'-10"	42						
A607	1	8	STR	12'-10"	34						
A608	1	8	STR	9'-11"	26						
A609	1	8	STR	6'-11"	18						
A610	1	8	STR	4'-0"	11						

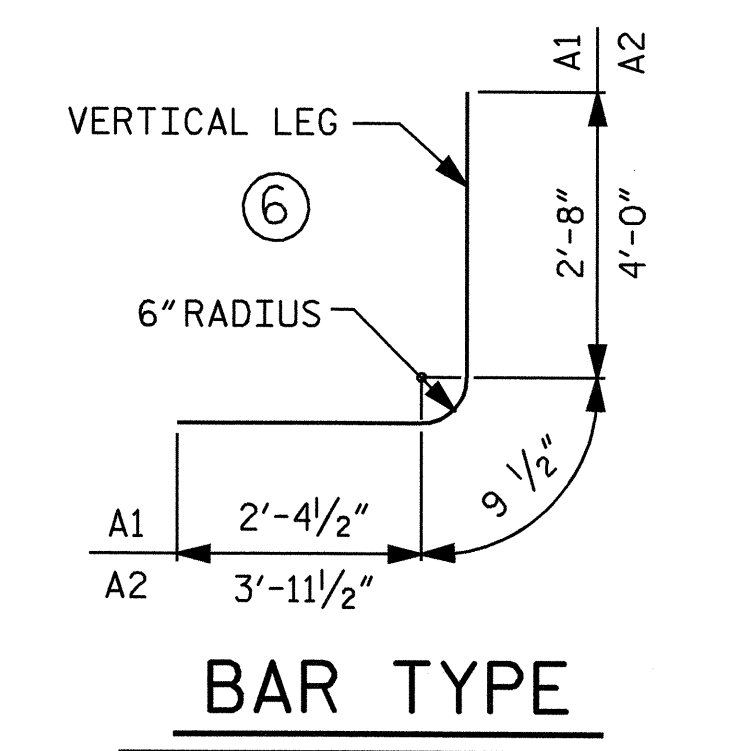

BAR TYPE

BAR DIMENSIONS ARE OUT TO OUT

PROJECT NO. B-4040
BURKE COUNTY
 STATION: 11+61.50 -L-

SHEET 3 OF 5

STATE OF NORTH CAROLINA
 DEPARTMENT OF TRANSPORTATION
 RALEIGH
 TRIPLE 9 FT. X 8 FT.
 CONCRETE BOX CULVERT
 80° SKEW

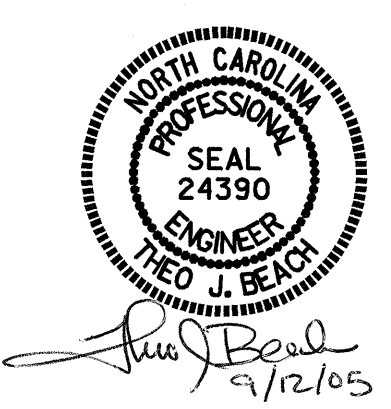

REVISIONS						SHEET NO.
NO.	BY:	DATE:	NO.	BY:	DATE:	C-3
1			3			TOTAL SHEETS
2			4			5

DRAWN BY : P.E. LACKEY DATE : 10/04
 CHECKED BY : S.B. WILLIAMS DATE : 10/04