

HALF SECTION @ POST-TENSIONING LOCATIONS HALF SECTION @ END BENT

TYPICAL SECTION

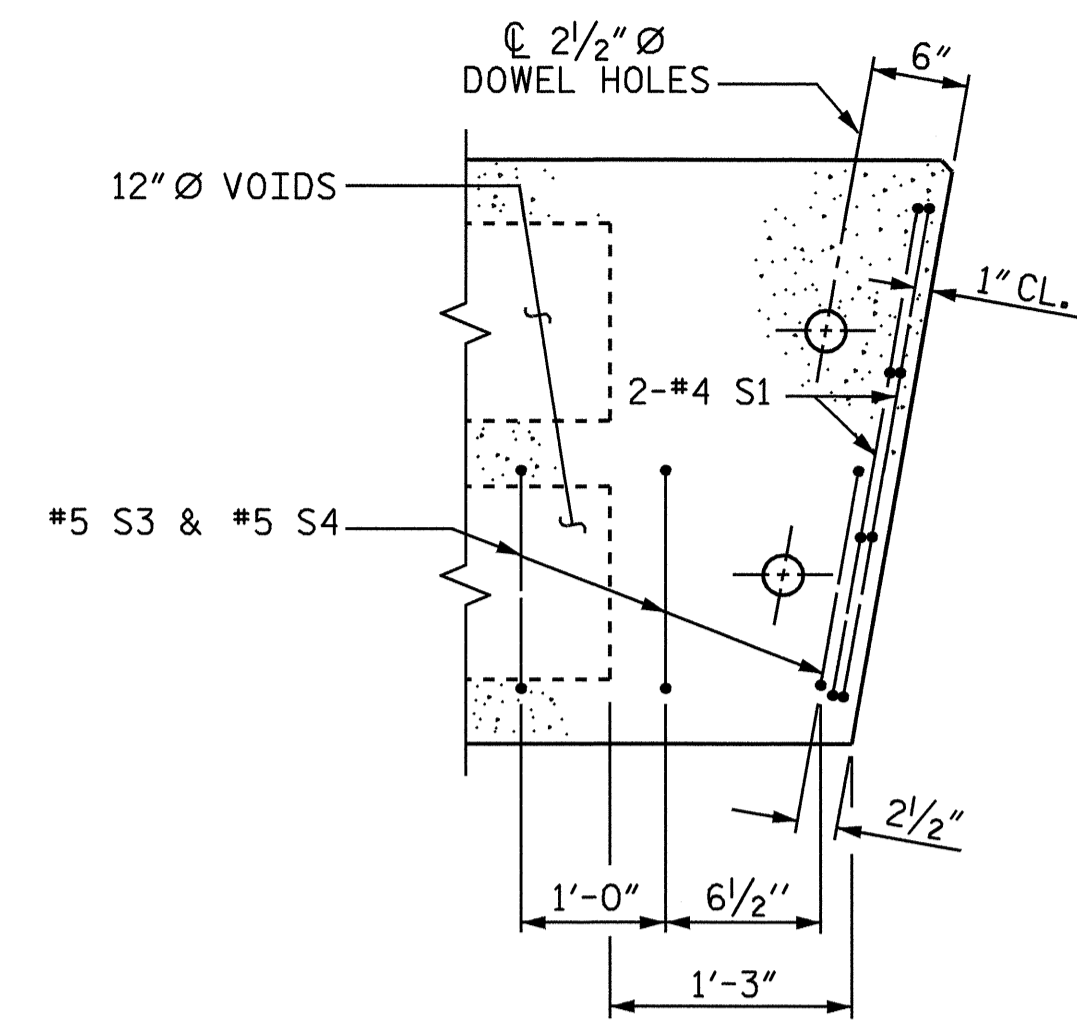

PART PLAN-EXTERIOR SECTION

NOTE: EXTERIOR SECTION SHOWN-INTERIOR SECTION SIMILAR EXCEPT OMIT S3 BARS.

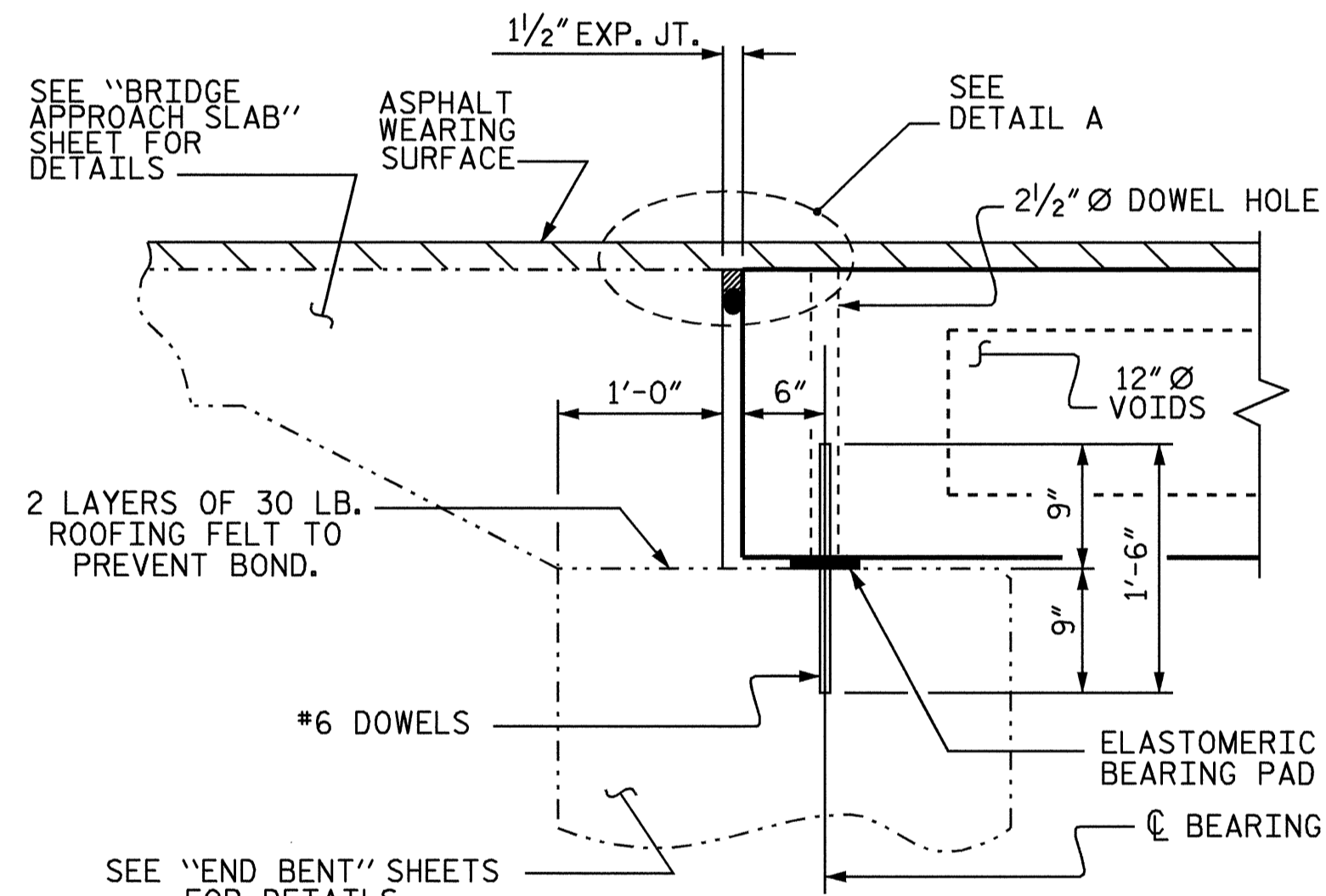

SECTION AT END BENT

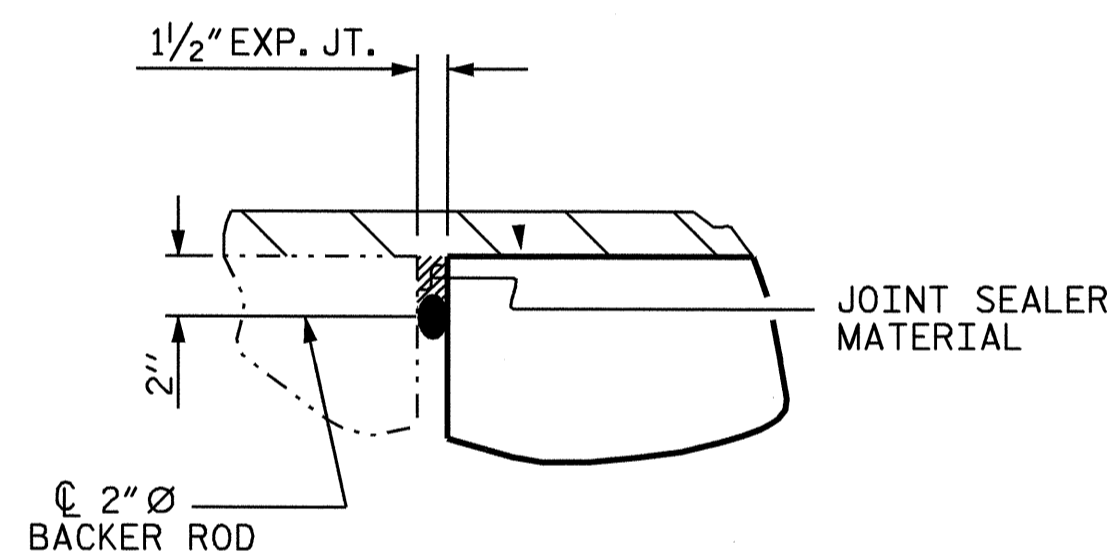

DETAIL A

□ BOND SHALL BE BROKEN ON THESE STRANDS FOR A DISTANCE OF 4.00 FEET FROM END OF CORED SLAB UNIT, SEE STANDARD SPECIFICATIONS ARTICLE 1078-7.

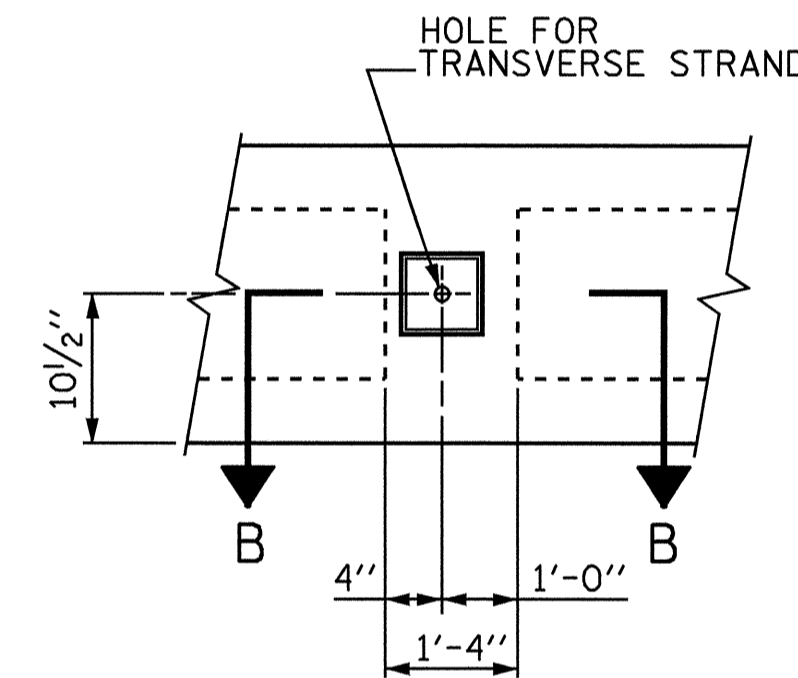

ELEVATION VIEW

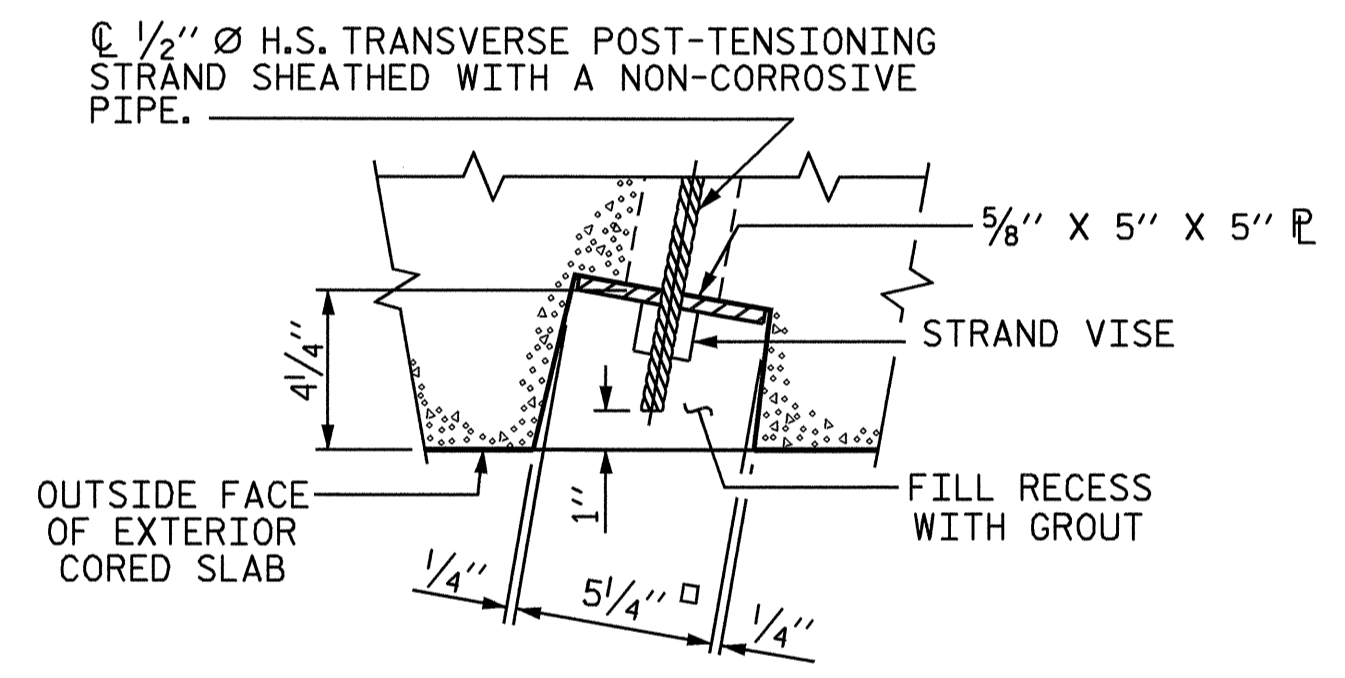

SECTION B-B

GRouted RECESS AT END OF POST-TENSIONED STRAND CORED SLABS

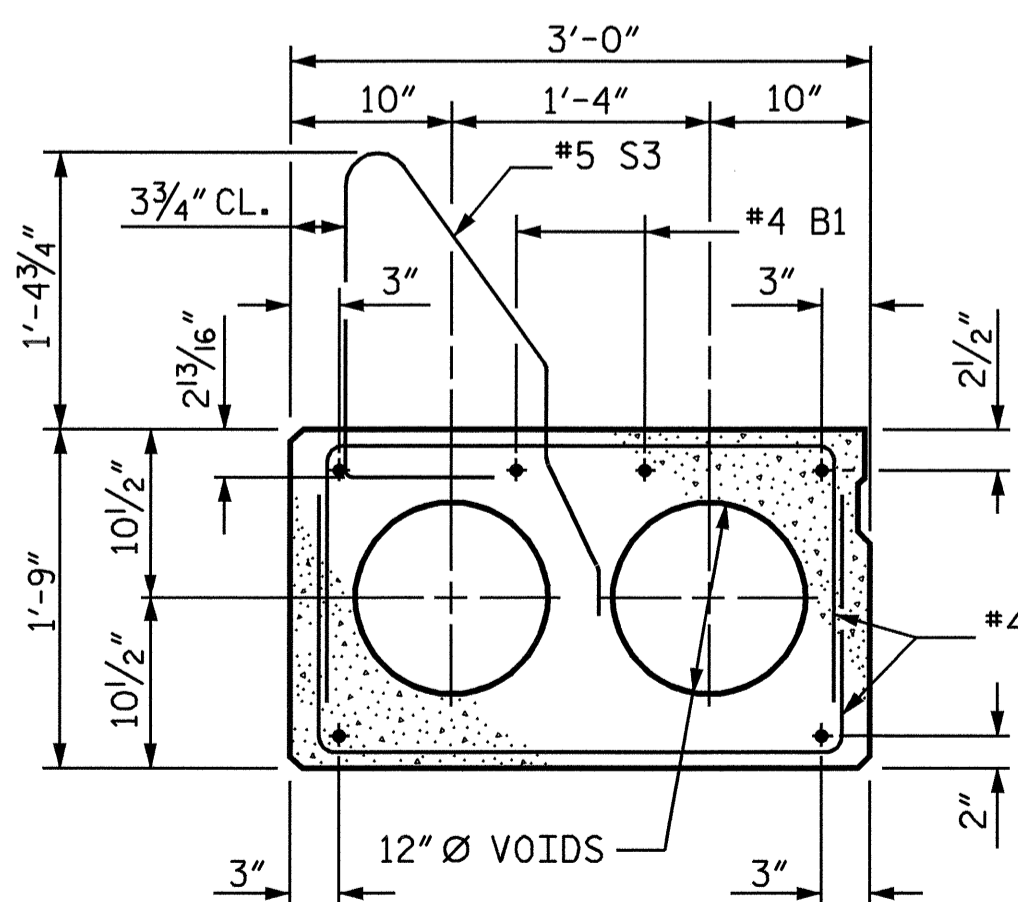

EXTERIOR SLAB SECTION

(FOR PRESTRESSED STRAND LAYOUT, SEE INTERIOR SLAB SECTION.)

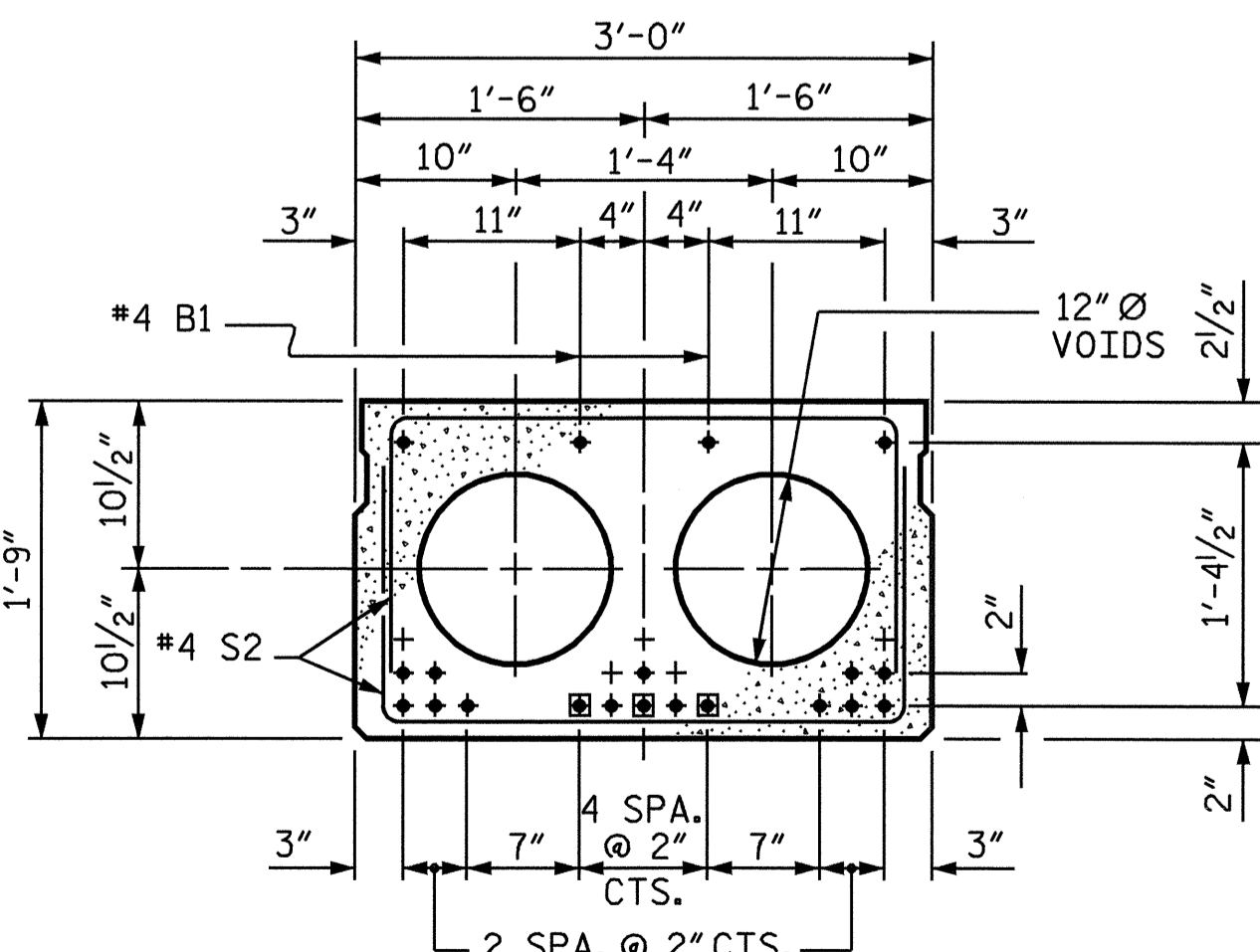

INTERIOR SLAB SECTION

1/2" Ø LOW RELAXATION STRAND LAYOUT

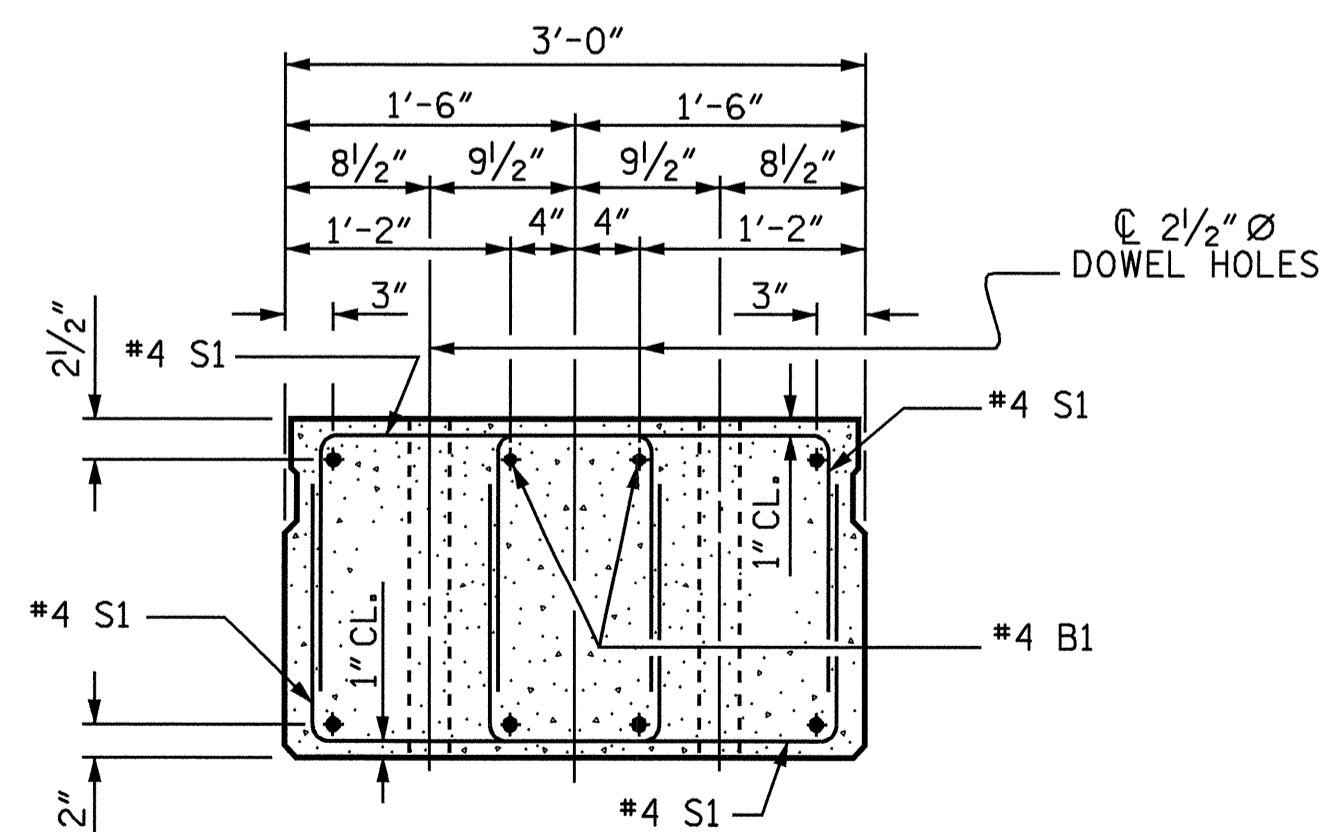

END ELEVATION

SHOWING PLACEMENT OF DOUBLE STIRRUPS AND LOCATION OF DOWEL HOLES. (STRAND LAYOUT NOT SHOWN.) INTERIOR SLAB SECTION SHOWN-EXTERIOR SLAB SECTION SIMILAR EXCEPT SHEAR KEY LOCATION.

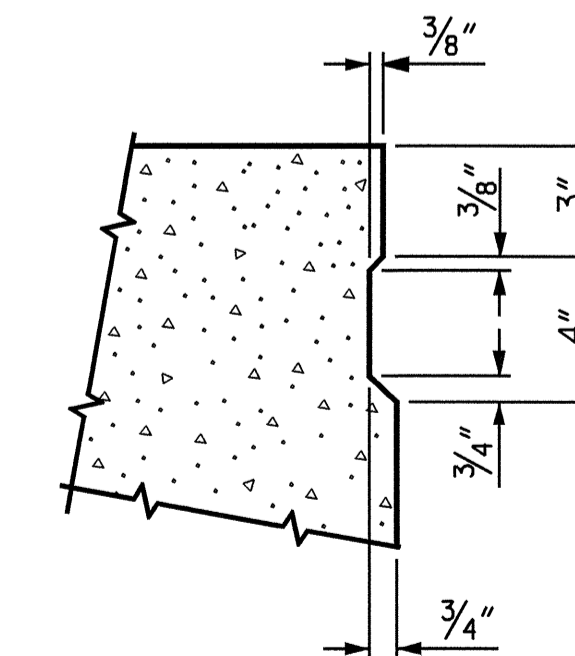

SHEAR KEY DETAIL

NOTE: OMIT SHEAR KEY ON OUTSIDE FACE OF EXTERIOR CORED SLABS.

DRAWN BY: C BECK/M. POOLE DATE: 04/03  
CHECKED BY: J. LAMBERT DATE: 08/04

08-DEC-2004 09:15  
W:\squadz\archive\b3914\m\poole\Microstat\on\b3914\_sd\_cs\_01.dgn  
mpoole



PROJECT NO. B-3914  
TRANSYLVANIA COUNTY  
STATION: 14+59.00 -L-

SHEET 1 OF 3

STATE OF NORTH CAROLINA  
DEPARTMENT OF TRANSPORTATION  
RALEIGH

SUPERSTRUCTURE  
3'-0" x 1'-9"  
PRESTRESSED CONCRETE  
CORED SLAB UNIT

REVISIONS						SHEET NO.
NO.	BY:	DATE:	NO.	BY:	DATE:	S-4
1			3			TOTAL SHEETS 18
2			4			