

**NOTES**

STIRRUPS IN CAP MAY BE SHIFTED AS NECESSARY TO CLEAR DOWELS & ANCHOR BOLTS.  
 ALL REINFORCING STEEL SHALL BE EPOXY COATED.  
 FOR EPOXY PROTECTIVE COATING, SEE SPECIAL PROVISIONS.  
 THE LATERAL GUIDE AND CONCRETE PLATFORM DECK ARE NOT TO BE POURED UNTIL AFTER THE CORED SLAB UNITS ARE IN PLACE.

4" Ø ANCHOR BOLTS SHALL BE EMBEDDED 6" INTO THE CONCRETE PLATFORM OR ADHESIVELY ANCHORED. SEE SPECIAL PROVISIONS.

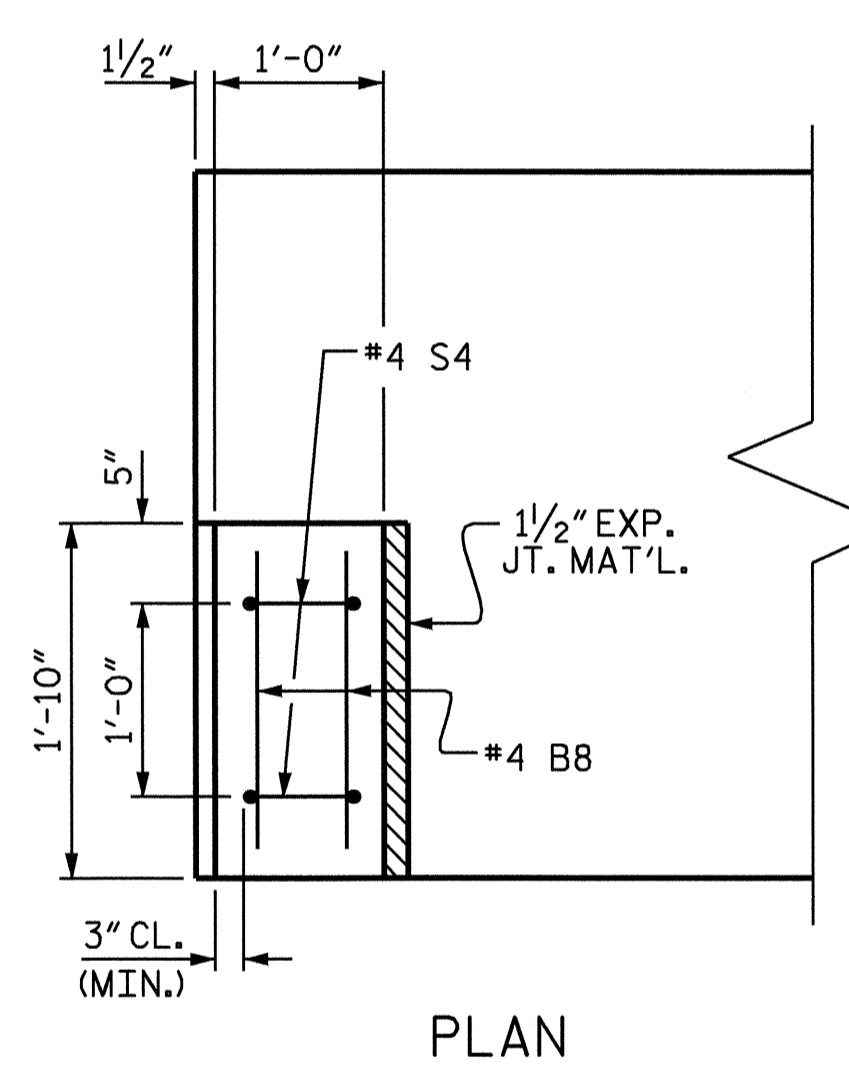
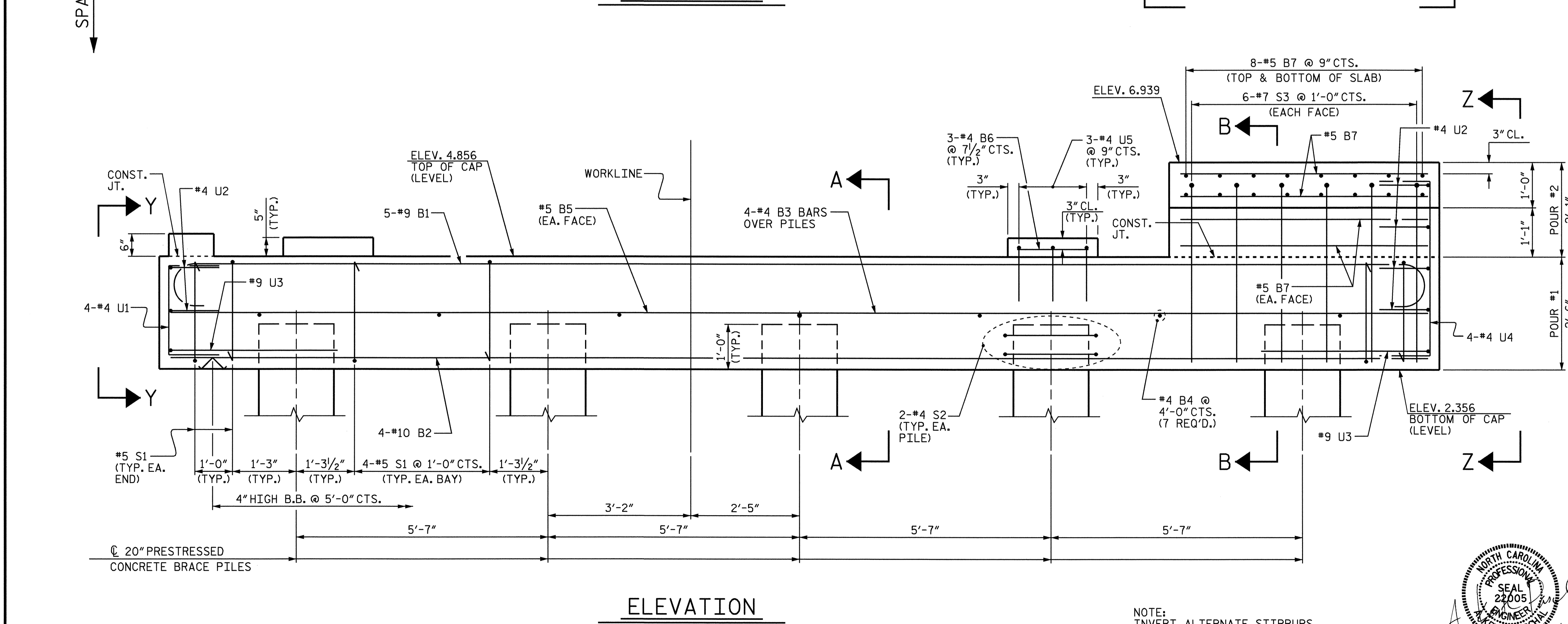
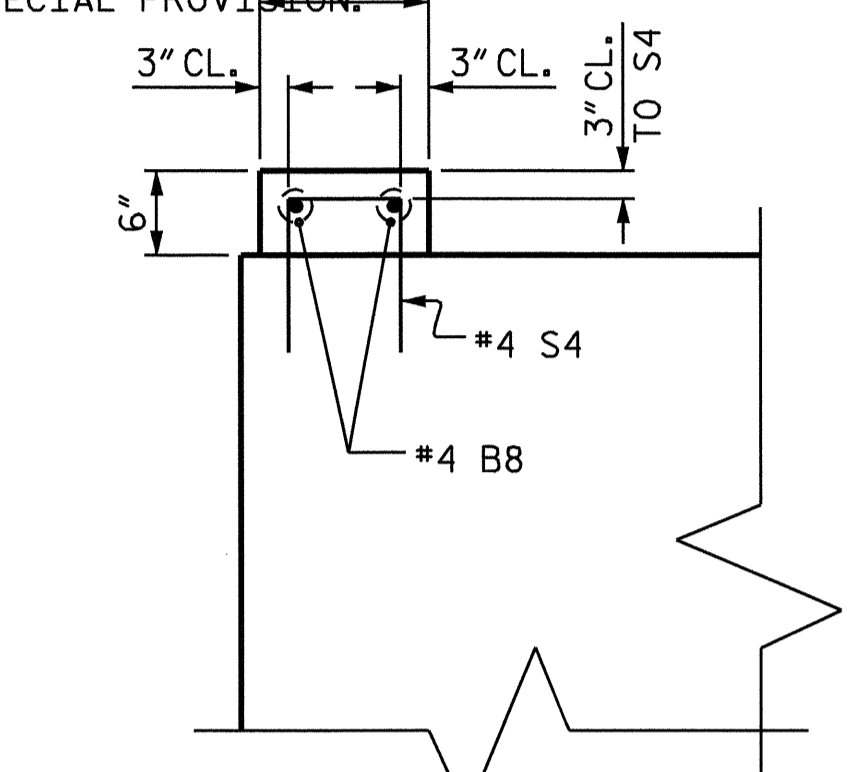
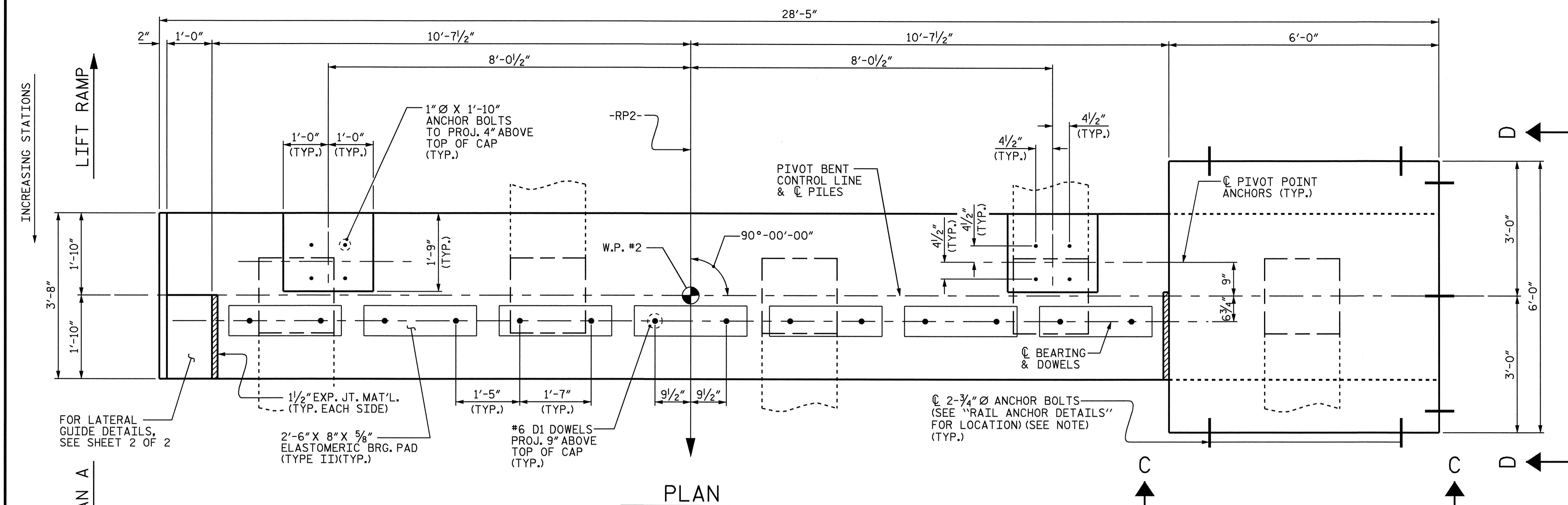

**LATERAL GUIDE**

PROJECT NO. F-4700  
 CURRITUCK COUNTY  
 STATION: 10+00.00 -RP2-

SHEET 1 OF 2

STATE OF NORTH CAROLINA  
 DEPARTMENT OF TRANSPORTATION  
 RALEIGH

**SUBSTRUCTURE  
 PIVOT BENT**

KNOTTS ISLAND FERRY BASIN

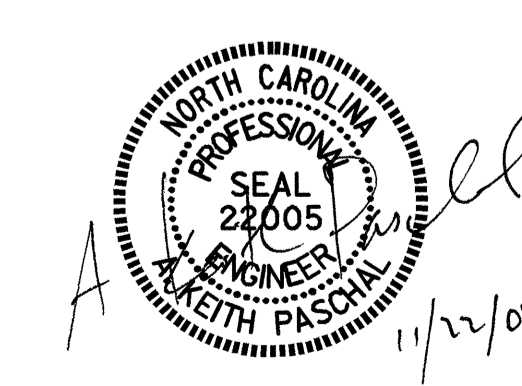

NOTE:  
 INVERT ALTERNATE STIRRUPS.

DRAWN BY : K. McCAULEY DATE : 9/21/04  
 CHECKED BY : O. PUIGCERVER DATE : 10/5/04

REVISIONS						SHEET NO.
NO.	BY:	DATE:	NO.	BY:	DATE:	S-46
1			3			TOTAL SHEETS
2			4			56