

NOTES

FOR ELASTOMERIC BEARINGS, SEE SPECIAL PROVISIONS.

AT ALL FIXED POINTS OF SUPPORT, NUTS FOR ANCHOR BOLTS ARE TO BE TIGHTENED FINGER TIGHT AND THEN BACKED OFF 1/2 TURN. THE THREAD OF THE NUT AND BOLT SHALL THEN BE BURRED WITH A SHARP POINTED TOOL.

THE 2" Ø PIPE SLEEVE SHALL BE CUT FROM SCHEDULE 40 PVC PLASTIC PIPE. THE PVC PLASTIC PIPE SHALL MEET THE REQUIREMENTS OF ASTM D1785.

STEEL SOLE PLATES, ANCHOR BOLTS, NUTS, AND WASHERS SHALL BE GALVANIZED IN ACCORDANCE WITH THE STANDARD SPECIFICATIONS.

PRIOR TO WELDING, GRIND THE GALVANIZED SURFACE OF THE PORTION OF THE EMBEDDED PLATE AND SOLE PLATE THAT ARE TO BE WELDED. AFTER WELDING, DAMAGED GALVANIZED SURFACES SHALL BE REPAIRED IN ACCORDANCE WITH THE STANDARD SPECIFICATIONS.

WHEN WELDING THE SOLE PLATE TO THE EMBEDDED PLATE IN THE GIRDER, USE TEMPERATURE INDICATING WAX PENS, OR OTHER SUITABLE MEANS, TO ENSURE THAT THE TEMPERATURE OF THE SOLE PLATE DOES NOT EXCEED 300°F. TEMPERATURES ABOVE THIS MAY DAMAGE THE ELASTOMER.

SOLE PLATE "P", BOLTS, NUTS, WASHERS, AND PIPE SLEEVE SHALL BE INCLUDED IN THE PAY ITEM FOR PRESTRESSED CONCRETE GIRDERS.

ANCHOR BOLTS SHALL MEET THE REQUIREMENTS OF ASTM A449. NUTS SHALL MEET THE REQUIREMENTS OF AASHTO M291-DH OR AASHTO M292-2H. WASHERS SHALL MEET THE REQUIREMENTS OF AASHTO M293. SHOP DRAWINGS ARE NOT REQUIRED FOR ANCHOR BOLT, NUTS AND WASHERS. SHOP INSPECTION IS REQUIRED.

ALL SURFACES OF BEARING PLATES SHALL BE SMOOTH AND STRAIGHT.

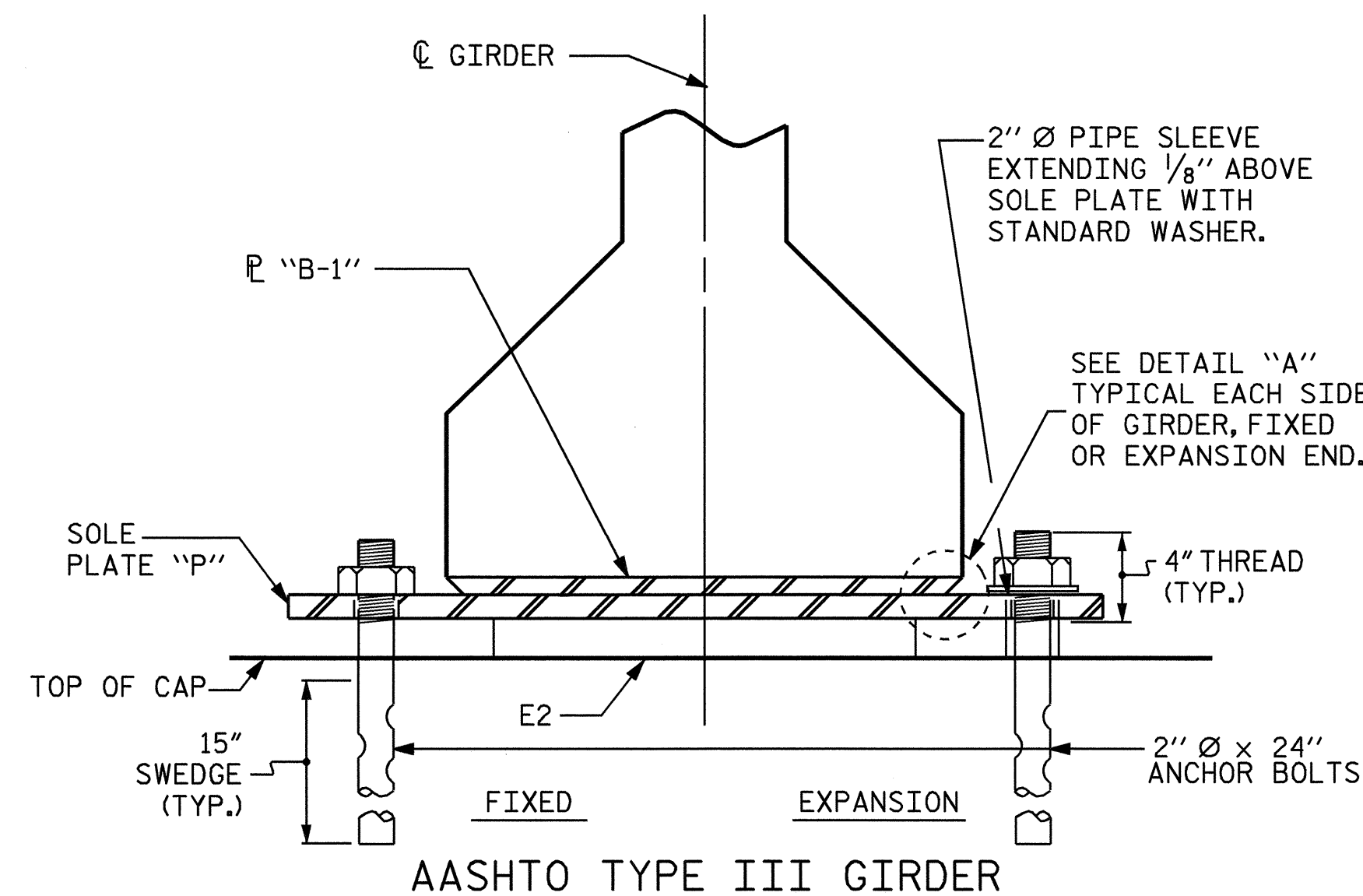
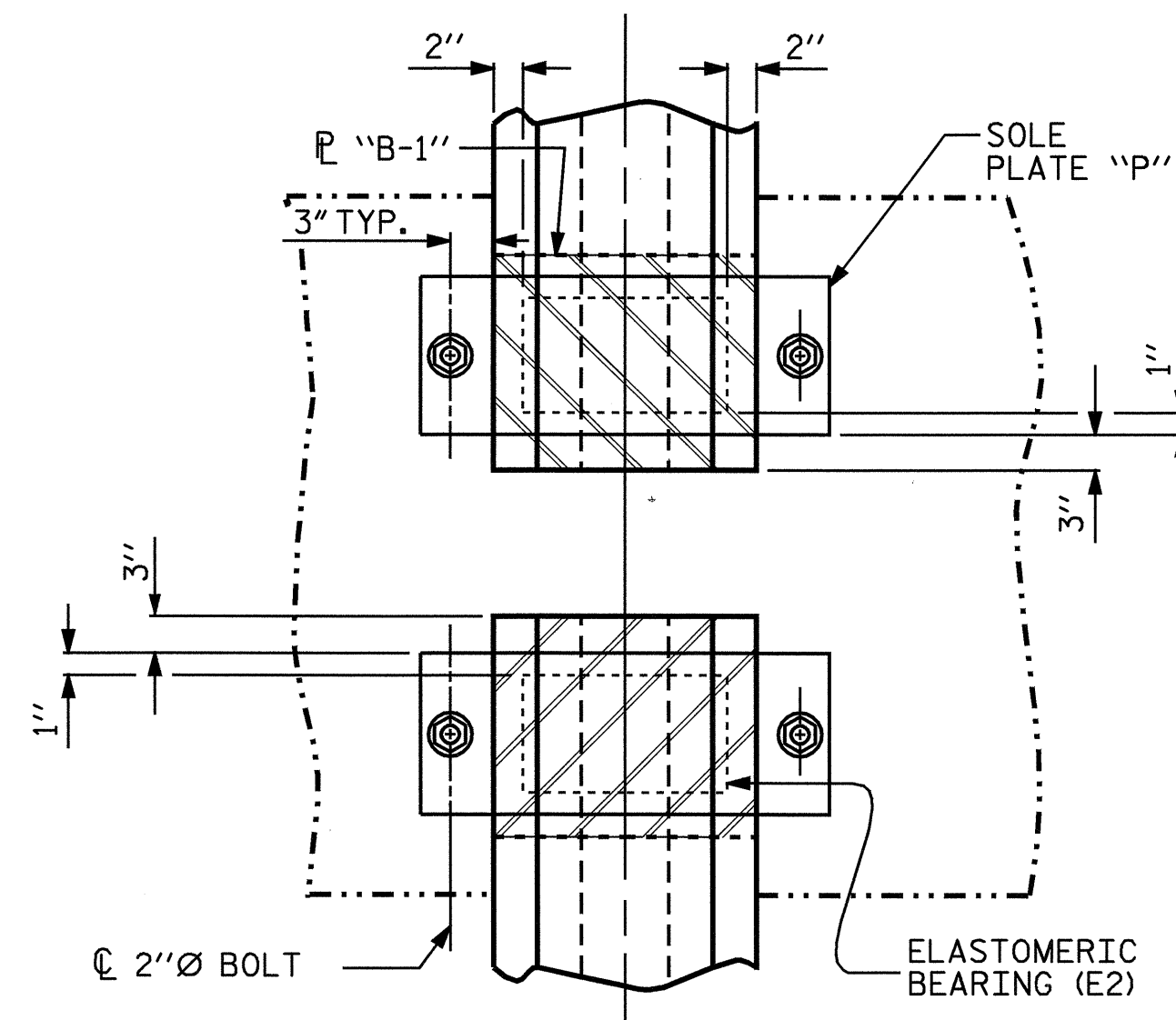

PLAN VIEW AT BENTS (FIXED)

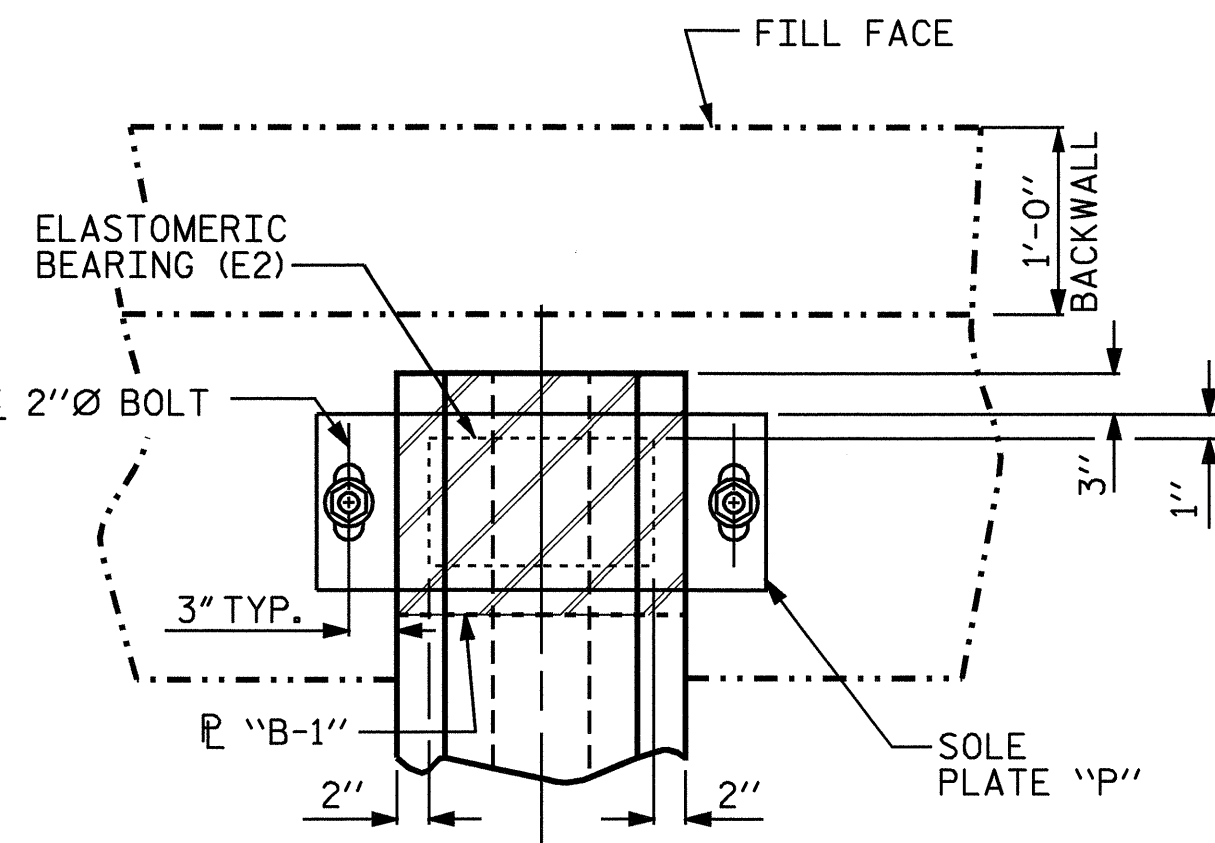

PLAN VIEW AT END BENTS (EXPANSION)

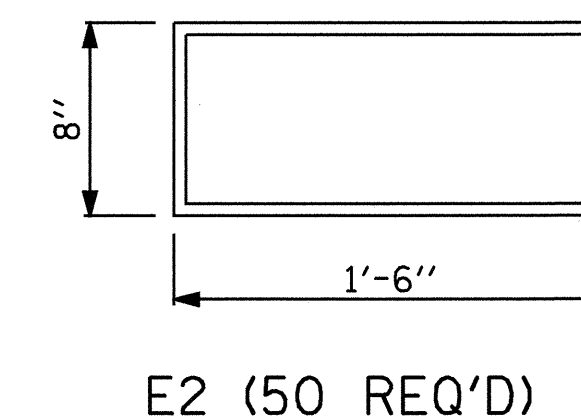
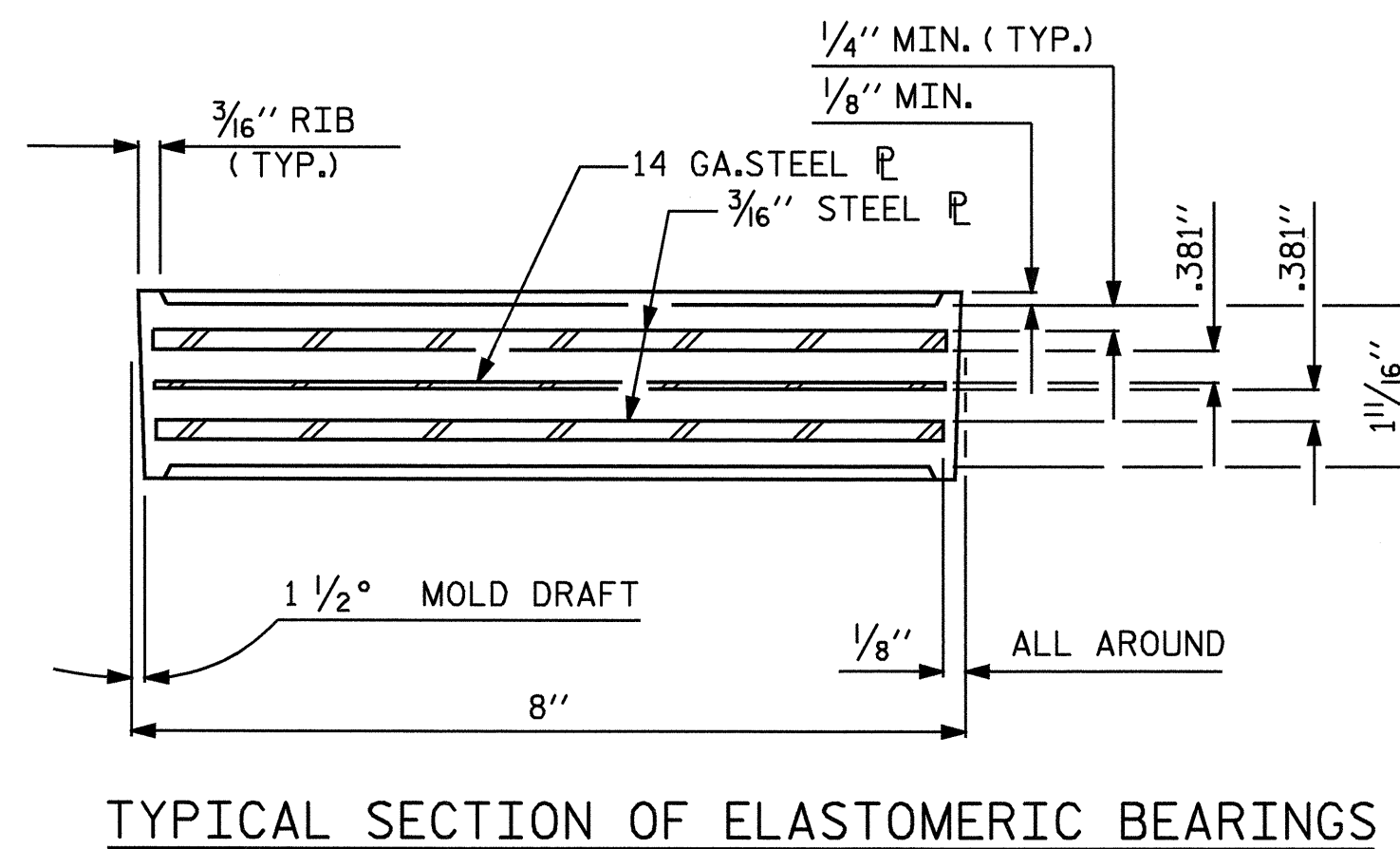

E2 (50 REQ'D)

TYPICAL SECTION OF ELASTOMERIC BEARINGS

PLAN VIEW OF ELASTOMERIC BEARING

TYPE III

| LOAD RATINGS | |
|------------------|---------------|
| | MAX.D.L.+L.L. |
| 45" PCG-TYPE III | 115 K |

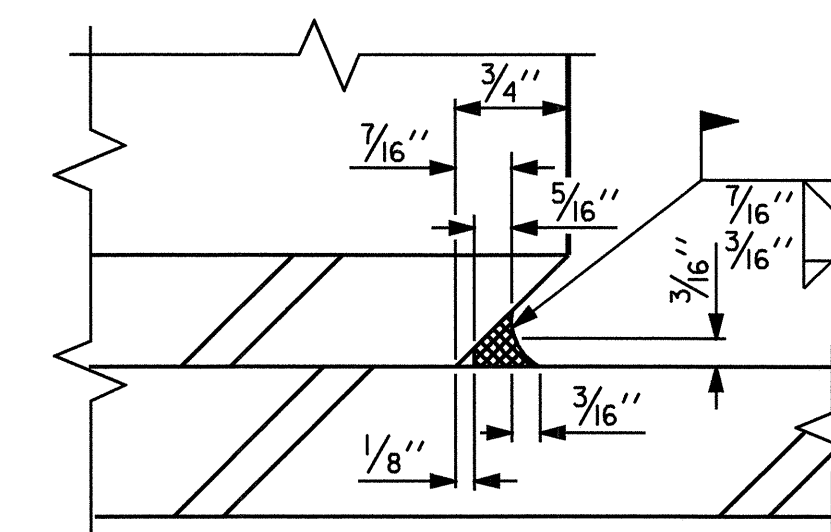

DETAIL "A"

PROJECT NO. B-3690
RANDOLPH COUNTY
 STATION: 17+41.00 -L-

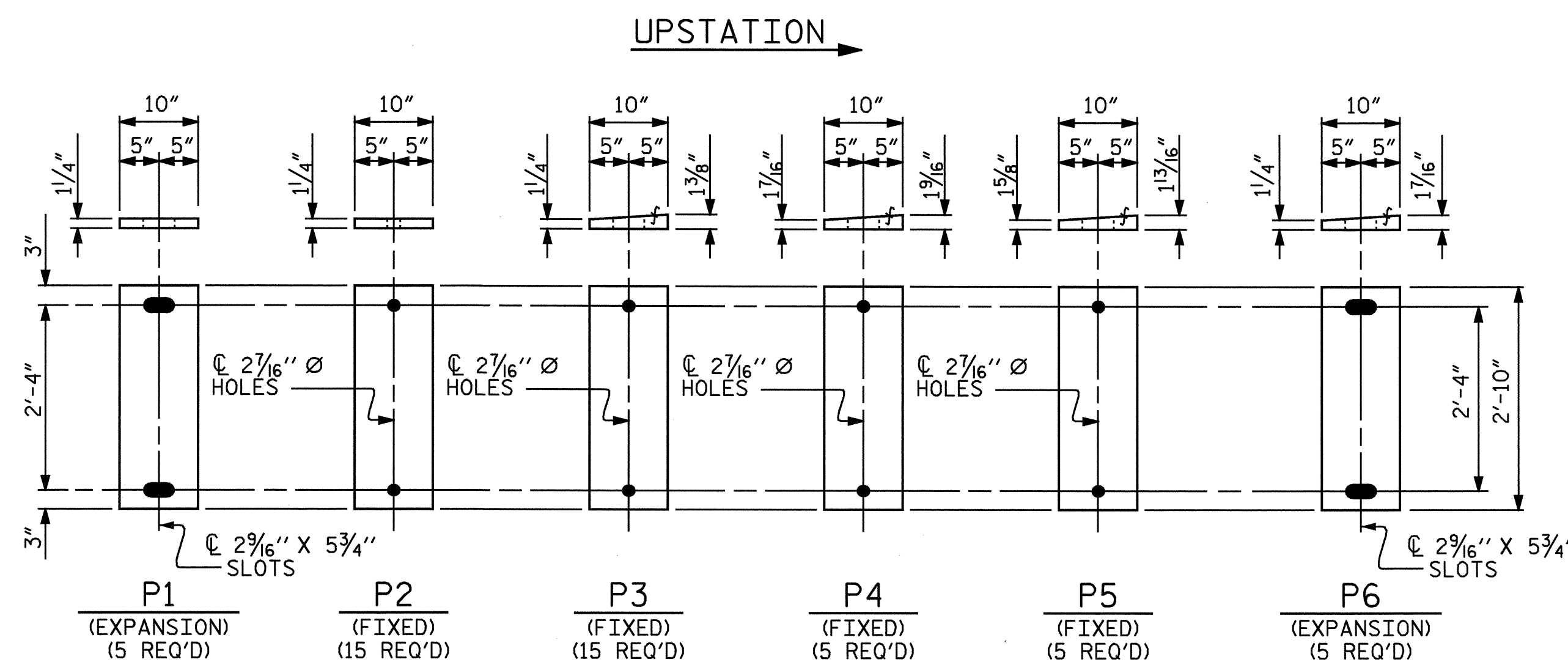

SOLE PLATE DETAILS ("P")

DRAWN BY: M. ALLEN DATE: 6/03
 CHECKED BY: P.C. BREWER DATE: 8/03

13-JUL-2004 07:50
 w:\sqdw\B3690\mallen\Microstation\B3690_sd.B6_01.dgn
 pbrewer

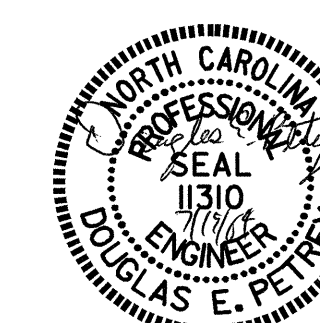

STATE OF NORTH CAROLINA
 DEPARTMENT OF TRANSPORTATION
 RALEIGH
**STANDARD
 ELASTOMERIC BEARING
 DETAILS**
 PRESTRESSED CONCRETE GIRDER
 SUPERSTRUCTURE

| REVISIONS | | | | | | TOTAL SHEETS |
|-----------|-----|-------|-----|-----|-------|--------------|
| NO. | BY: | DATE: | NO. | BY: | DATE: | 37 |
| 1 | | | 3 | | | 37 |
| 2 | | | 4 | | | |
| | | | | | | |