

NOTES

STIRRUPS IN CAP MAY BE SHIFTED AS NECESSARY TO CLEAR ANCHOR BOLTS.

HOOKS ON "V" BARS MAY BE TURNED AS NECESSARY FOR PLACING REINFORCING STEEL.

ALL STEEL IN THE DRILLED PIERS IS INCLUDED IN THE PAY ITEMS FOR "REINFORCING STEEL" AND "SPIRAL COLUMN REINFORCING STEEL" OR "EPOXY COATED SPIRAL COLUMN REINFORCING STEEL".

SPLICING OF THE LONGITUDINAL BARS IN THE DRILLED PIER WILL NOT BE PERMITTED.

MECHANICAL COUPLERS SHALL BE USED TO JOIN THE LONGITUDINAL DRILLED PIER REINFORCING STEEL TO THE COLUMN REINFORCING STEEL. THE HEIGHT OF THE COUPLERS SHALL BE STAGGERED ON ALTERNATING BARS BY 1 FOOT AND THE DRILLED PIER AND COLUMN STEEL SHALL BE CUT ACCORDINGLY. SEE SPECIAL PROVISIONS FOR MECHANICAL BUTT SPLICING FOR REINFORCING STEEL.

THE LOCATION OF THE CONSTRUCTION JOINT IN THE DRILLED PIERS IS BASED ON AN APPROXIMATE GROUND LINE ELEVATION. IF THE CONSTRUCTION JOINT IS ABOVE THE ACTUAL GROUND LINE ELEVATION, THE CONTRACTOR SHALL PLACE THE CONSTRUCTION JOINT 1 FT. BELOW THE GROUND LINE.

FOR PERMANENT STEEL CASING, SEE SPECIAL PROVISION FOR DRILLED PIERS.

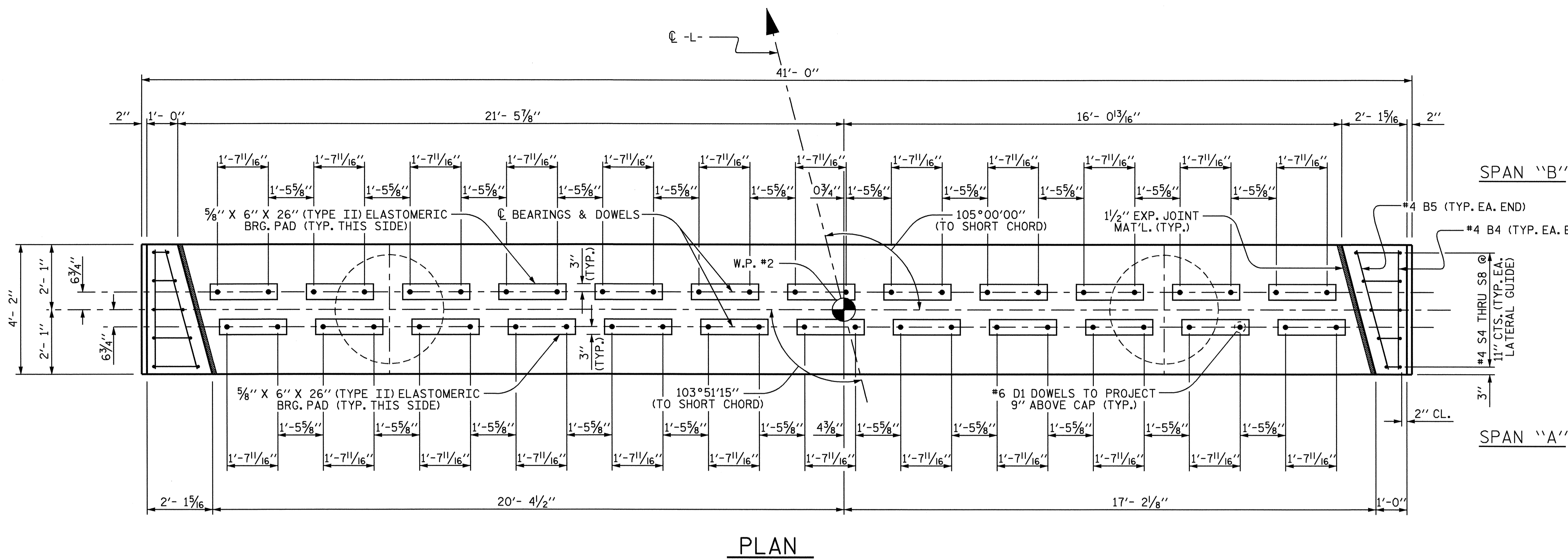

PLAN

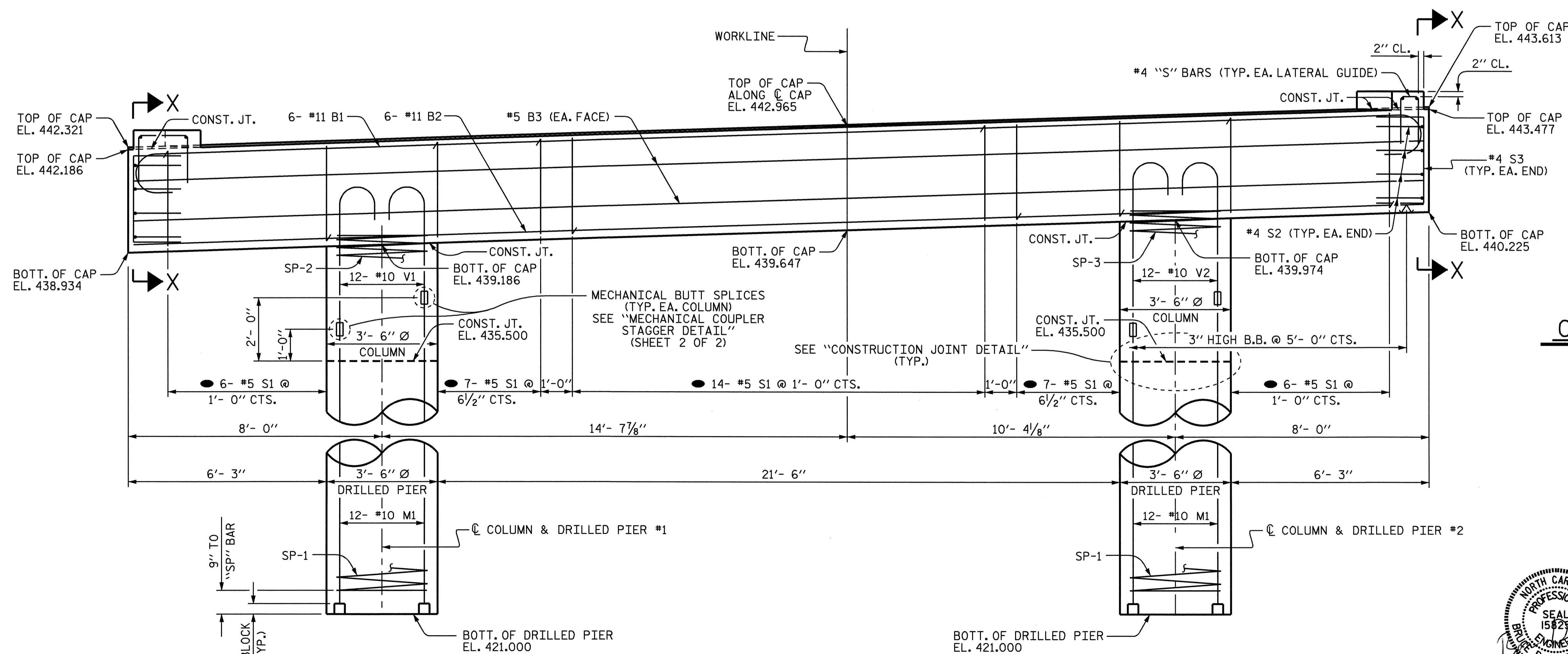

ELEVATION

(INVERT ALTERNATE STIRRUPS AS SHOWN)

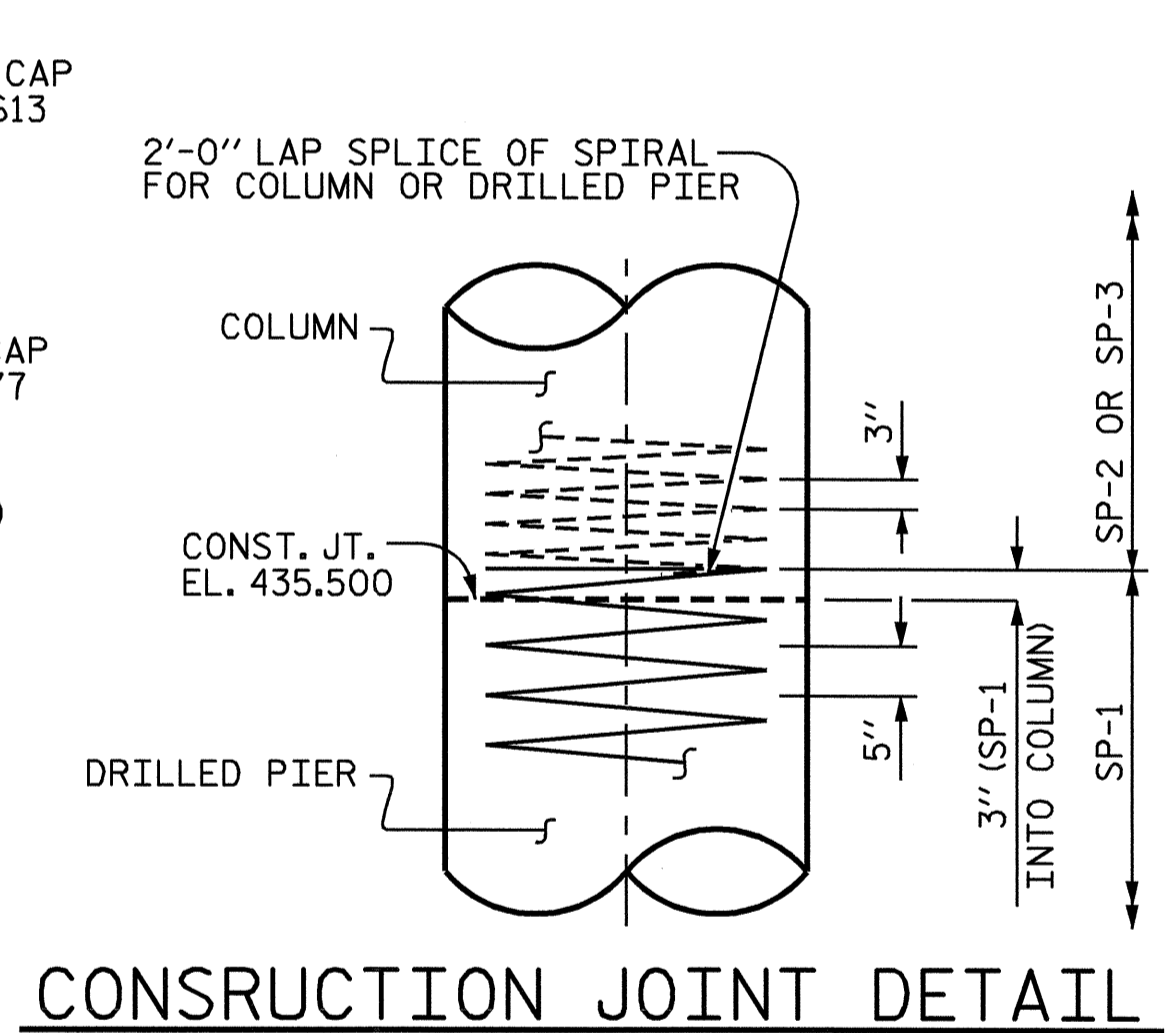

CONSTRUCTION JOINT DETAIL

PROJECT NO. B-3504  
 RANDOLPH COUNTY  
 STATION: 18+70.50 -L-

SHEET 1 OF 2

STATE OF NORTH CAROLINA DEPARTMENT OF TRANSPORTATION RALEIGH					
SUBSTRUCTURE BENT #1					
REVISIONS					
NO.	BY:	DATE:	NO.	BY:	DATE:
1			3		
2			4		

SHEET NO.  
S-15  
TOTAL SHEETS  
27

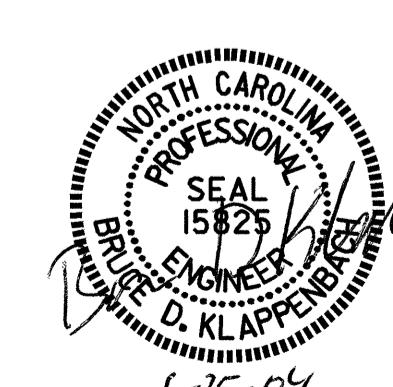

DRAWN BY: D. A. GLADDEN DATE: 5-13-04  
 CHECKED BY: M. G. SHAIKH DATE: 6-16-04

25-JUN-2004 15:50  
 w:\squad\B3504\gladden\Microstation\B3504bt.dgn  
 bklappenbach