

SECTION "A-A"

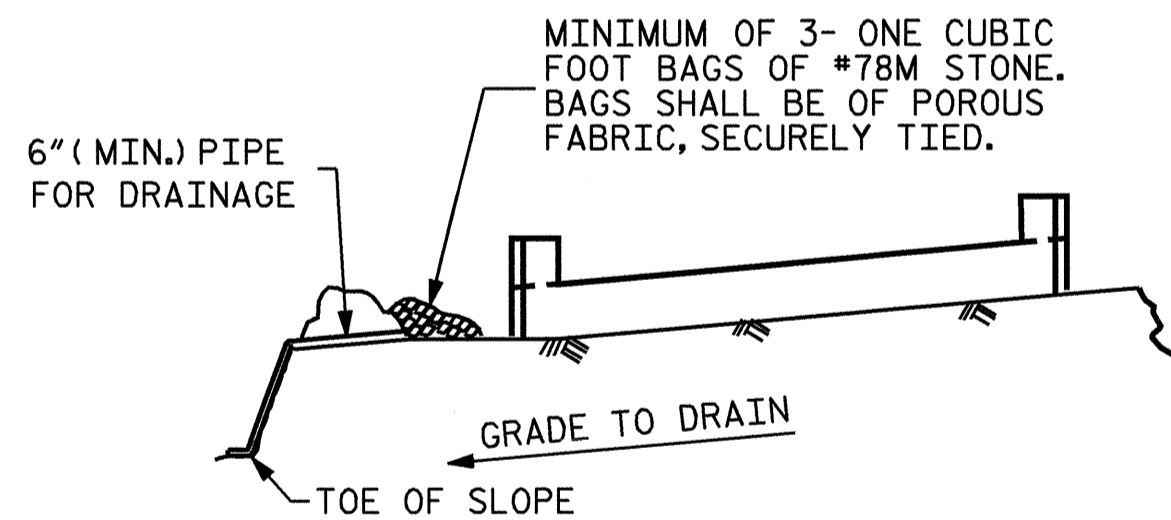

BAGGED STONE AND PIPE SHALL BE PLACED IMMEDIATELY AFTER COMPLETION OF END BENT EXCAVATION. PIPE MAY BE EITHER CONCRETE, CORRUGATED STEEL, CORRUGATED ALUMINUM ALLOY, OR CORRUGATED PLASTIC. PERFORATED PIPE WILL NOT BE ALLOWED.

BAGGED STONE SHALL REMAIN IN PLACE UNTIL THE ENGINEER DIRECTS THAT IT BE REMOVED. THE CONTRACTOR SHALL REMOVE AND DISPOSE OF SILT ACCUMULATIONS AT BAGGED STONE WHEN SO DIRECTED BY THE ENGINEER. BAGS SHALL BE REMOVED AND REPLACED WHENEVER THE ENGINEER DETERMINES THAT THEY HAVE DETERIORATED AND LOST THEIR EFFECTIVENESS.

NO SEPARATE PAYMENT WILL BE MADE FOR THIS WORK AND THE ENTIRE COST OF THIS WORK SHALL BE INCLUDED IN THE UNIT CONTRACT PRICE BID FOR THE SEVERAL PAY ITEMS.

TEMPORARY DRAINAGE AT END BENT

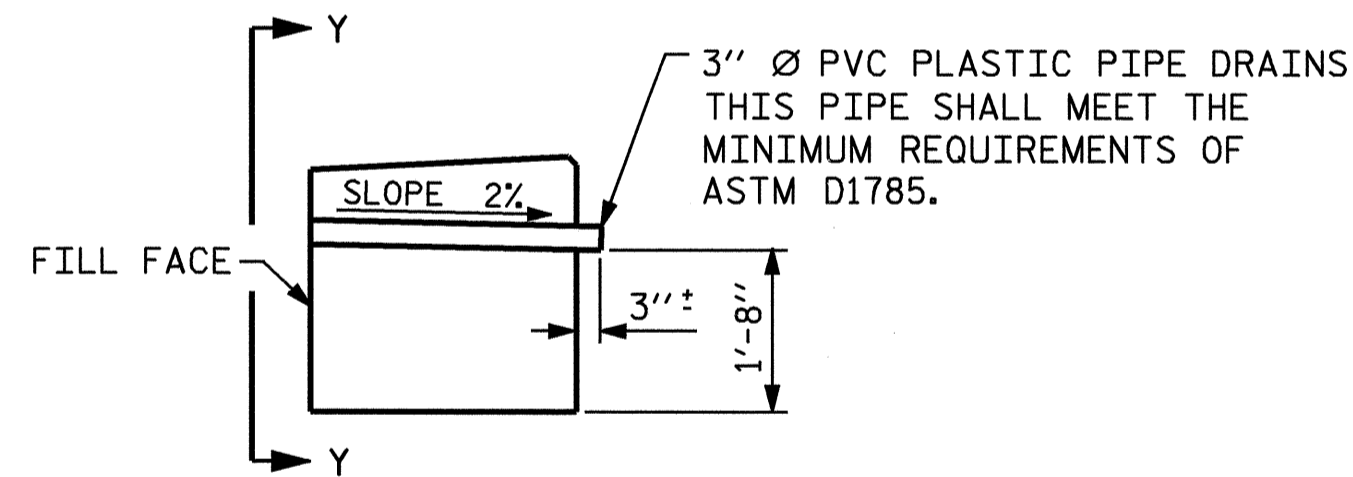

SECTION THRU CAP

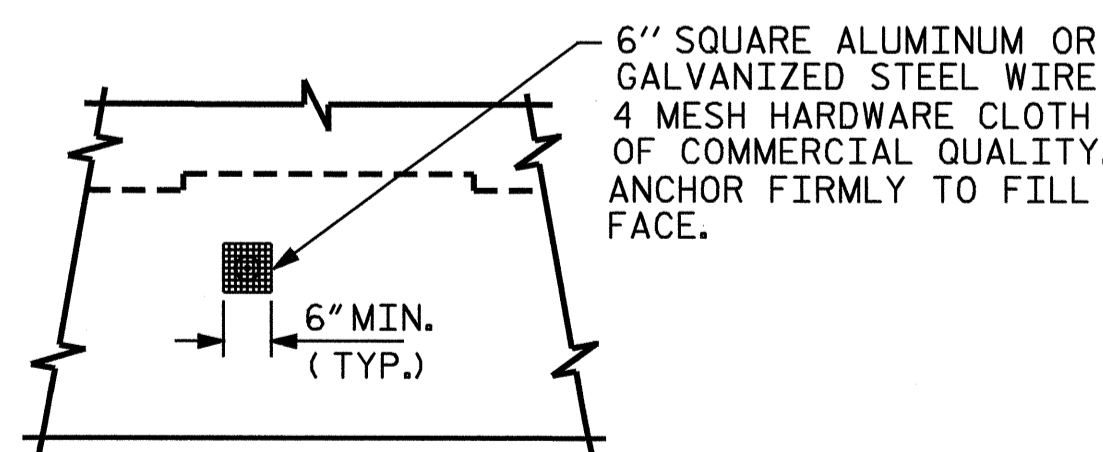

VIEW Y-Y

NOTE: NO SEPARATE PAYMENT WILL BE MADE FOR FURNISHING AND INSTALLING THE PVC PLASTIC PIPE DRAINS, HARDWARE CLOTH AND FASTENERS. THE ENTIRE COST OF THIS WORK SHALL BE INCLUDED IN THE UNIT CONTRACT PRICE BID FOR THE SEVERAL PAY ITEMS.

PIPE DRAIN DETAILS

BAR TYPES

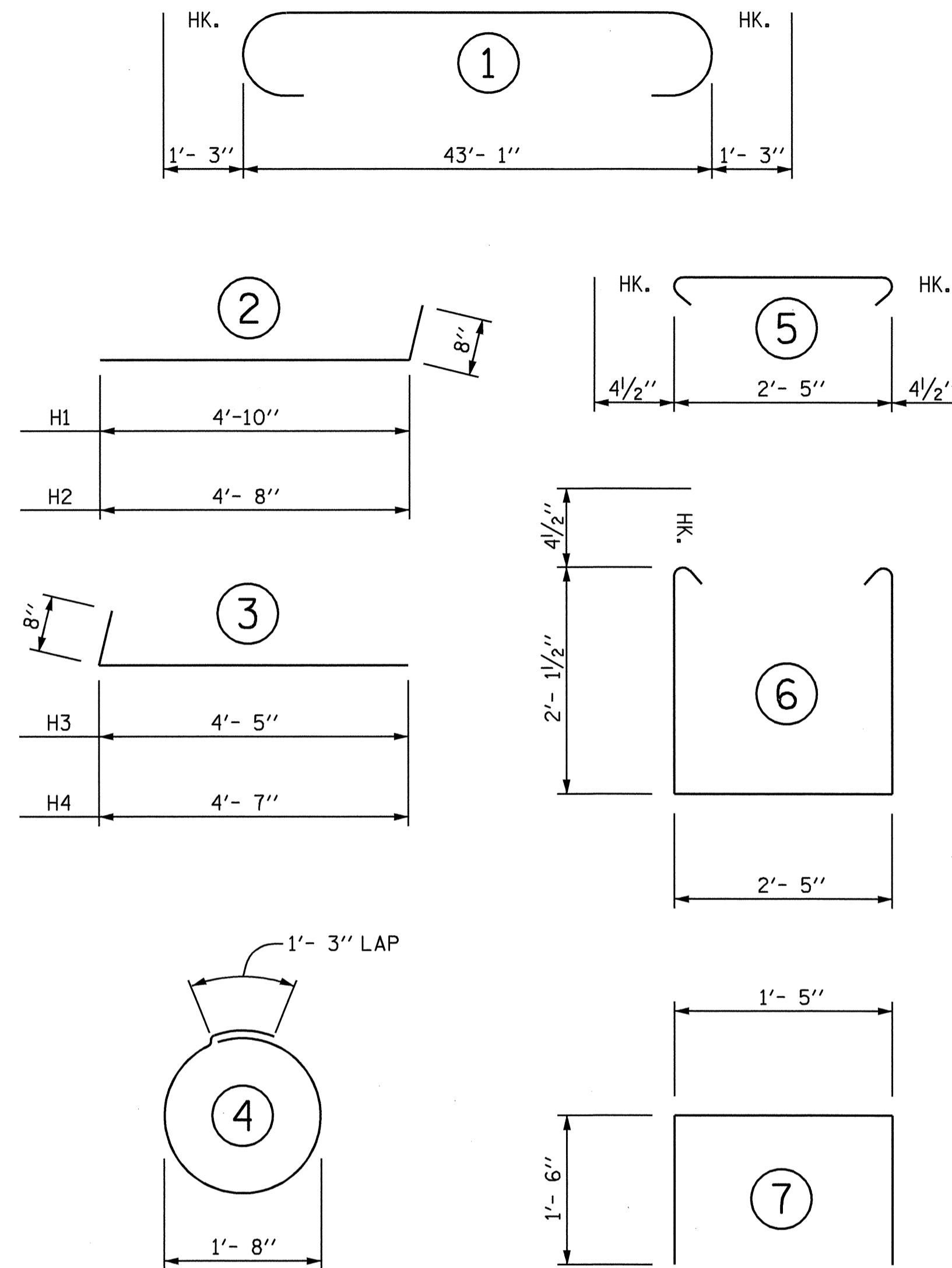

ALL BAR DIMENSIONS ARE OUT TO OUT.

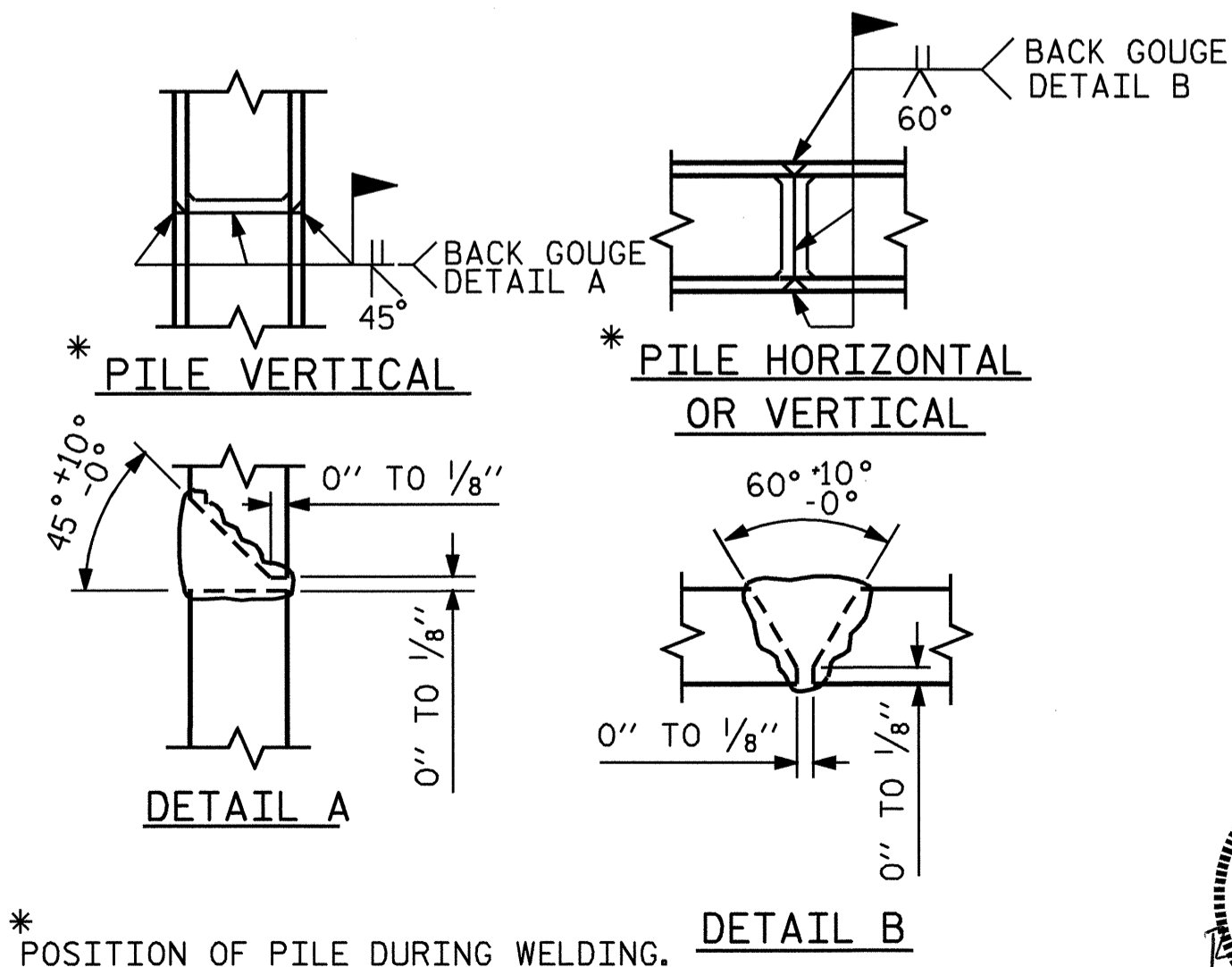

* POSITION OF PILE DURING WELDING.

PILE SPLICE DETAILS

BILL OF MATERIAL

END BENT #2

BAR	NO.	SIZE	TYPE	LENGTH	WEIGHT
B1	8	#9	1	45'- 7"	1240
B2	2	#6	STR	43'- 3"	130
B3	8	#4	STR	22'- 10'	122
B4	11	#4	STR	2'- 5"	18
D1	24	#6	STR	1'- 6"	54
H1	5	#4	2	5'- 6"	18
H2	5	#4	2	5'- 4"	18
H3	6	#4	3	5'- 1"	20
H4	6	#4	3	5'- 3"	21
S1	42	#4	5	3'- 2"	89
S2	42	#4	6	7'- 5"	208
S3	12	#4	4	6'- 6"	52
S4	10	#4	STR	2'- 8"	18
S5	4	#4	7	4'- 5"	12
V1	18	#4	STR	4'- 2"	50
V2	16	#4	STR	3'-11"	42

REINFORCING STEEL = 2112 LBS

CLASS A CONCRETE BREAKDOWN

POUR #1 (CAP & BOTT. OF WINGS)	12.0 C.Y.
POUR #2 (TOP OF WINGS)	1.0 C.Y.
POUR #3 (LATERAL GUIDES)	0.1 C.Y.
CLASS A CONCRETE TOTAL	13.1 C.Y.

HP 12x53 STEEL PILES

NO. 6 LIN. FT. 120

STEEL PILE POINTS NO. 6

PROJECT NO. B-3504
RANDOLPH COUNTY
 STATION: 18+70.50 -L-

SHEET 3 OF 3

STATE OF NORTH CAROLINA
 DEPARTMENT OF TRANSPORTATION
 RALEIGH

**SUBSTRUCTURE
 END BENT #2**

REVISIONS

NO.	BY:	DATE:	NO.	BY:	DATE:
1			3		
2			4		

SHEET NO. 5-21
 TOTAL SHEETS 27

DRAWN BY: D. A. GLADDEN DATE: 5-13-04
 CHECKED BY: M. G. SHAIKH DATE: 6-14-04